

To all our customers

---

## **Regarding the change of names mentioned in the document, such as Mitsubishi Electric and Mitsubishi XX, to Renesas Technology Corp.**

---

The semiconductor operations of Hitachi and Mitsubishi Electric were transferred to Renesas Technology Corporation on April 1st 2003. These operations include microcomputer, logic, analog and discrete devices, and memory chips other than DRAMs (flash memory, SRAMs etc.) Accordingly, although Mitsubishi Electric, Mitsubishi Electric Corporation, Mitsubishi Semiconductors, and other Mitsubishi brand names are mentioned in the document, these names have in fact all been changed to Renesas Technology Corp. Thank you for your understanding. Except for our corporate trademark, logo and corporate statement, no changes whatsoever have been made to the contents of the document, and these changes do not constitute any alteration to the contents of the document itself.

Note : Mitsubishi Electric will continue the business operations of high frequency & optical devices and power devices.

Renesas Technology Corp.  
Customer Support Dept.  
April 1, 2003

# MITSUBISHI MICROCOMPUTERS 7516 Group (Spec. H)

SINGLE-CHIP 8-BIT CMOS MICROCOMPUTER

## DESCRIPTION

The 7516 group (Spec. H) is the 8-bit microcomputer based on the 740 family core technology.

The 7516 group (Spec. H) is designed for the household products and office automation equipment and includes serial I/O functions, 8-bit timer, A-D converter, and I<sup>2</sup>C-BUS interface.

## FEATURES

- Basic machine-language instructions ..... 71
- Minimum instruction execution time ..... 0.5 μs  
(at 8 MHz oscillation frequency)
- Memory size  
ROM ..... 16 K to 24 K bytes  
RAM ..... 512 to 640 bytes
- Programmable input/output ports ..... 36
- Interrupts ..... 17 sources, 16 vectors
- Timers ..... 8-bit X 4
- Serial I/O1 ..... 8-bit X 1 (UART or Clock-synchronized)
- Serial I/O2 ..... 8-bit X 1 (Clock-synchronized)
- Multi-master I<sup>2</sup>C-BUS interface (option) ..... 1 channel
- PWM ..... 8-bit X 1
- A-D converter ..... 10-bit X 6 channels
- Watchdog timer ..... 16-bit X 1

- Clock generating circuit ..... Built-in 2 circuits  
(connect to external ceramic resonator or quartz-crystal oscillator)
- Power source voltage  
In high-speed mode ..... 4.0 to 5.5 V  
(at 8 MHz oscillation frequency)  
In high-speed mode ..... 2.7 to 5.5 V  
(at 4 MHz oscillation frequency)  
In middle-speed mode ..... 2.7 to 5.5 V  
(at 8 MHz oscillation frequency)  
In low-speed mode ..... 2.7 to 5.5 V  
(at 32 kHz oscillation frequency)
- Power dissipation  
In high-speed mode ..... 34 mW  
(at 8 MHz oscillation frequency, at 5 V power source voltage)  
In low-speed mode ..... 60 μW  
(at 32 kHz oscillation frequency, at 3 V power source voltage)
- Operating temperature range ..... -20 to 85°C

## APPLICATION

Office automation equipment, FA equipment, Household products, Consumer electronics, etc.

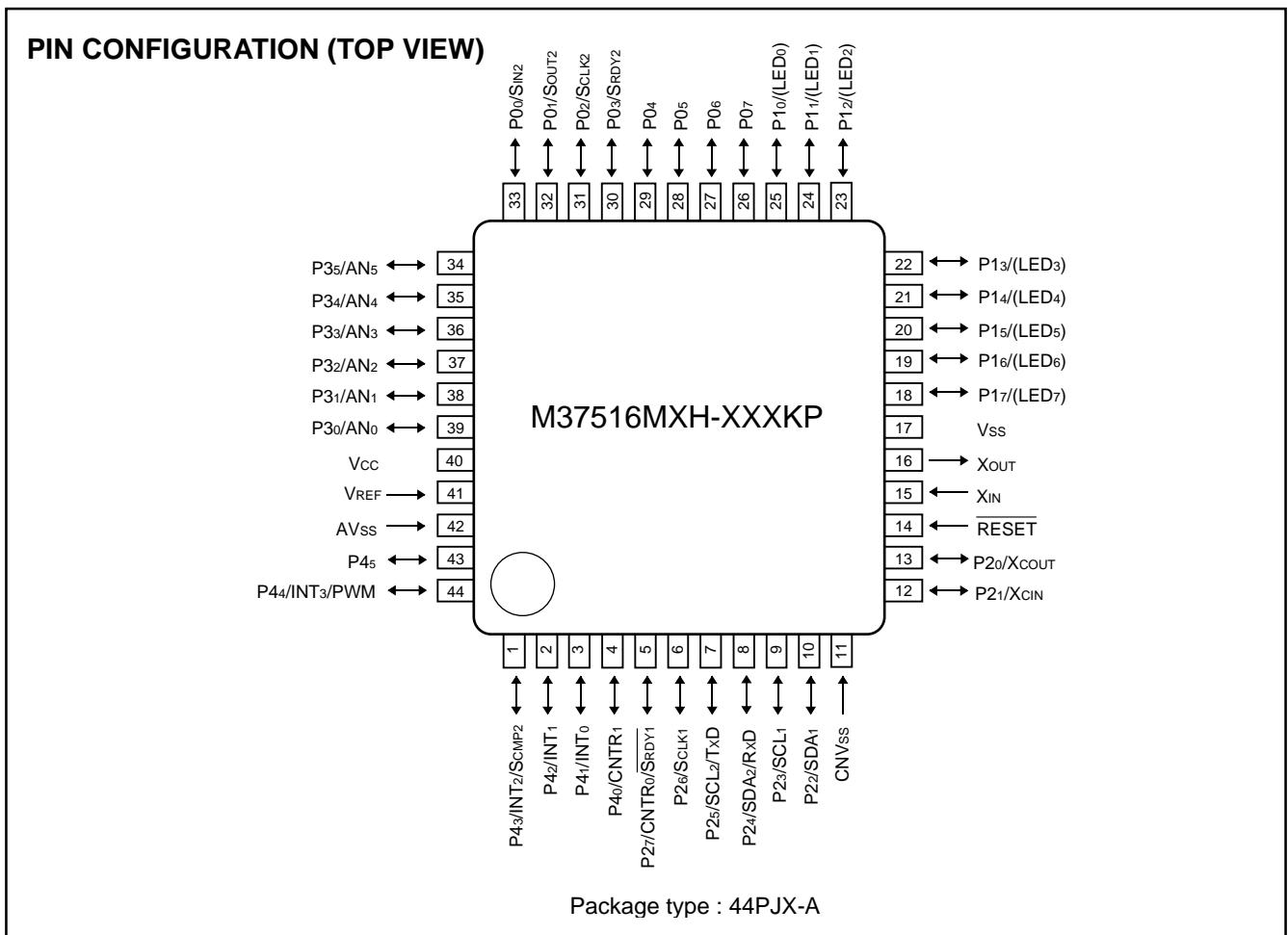

Fig. 1 M37516MXH-XXXXP pin configuration

FUNCTIONAL BLOCK

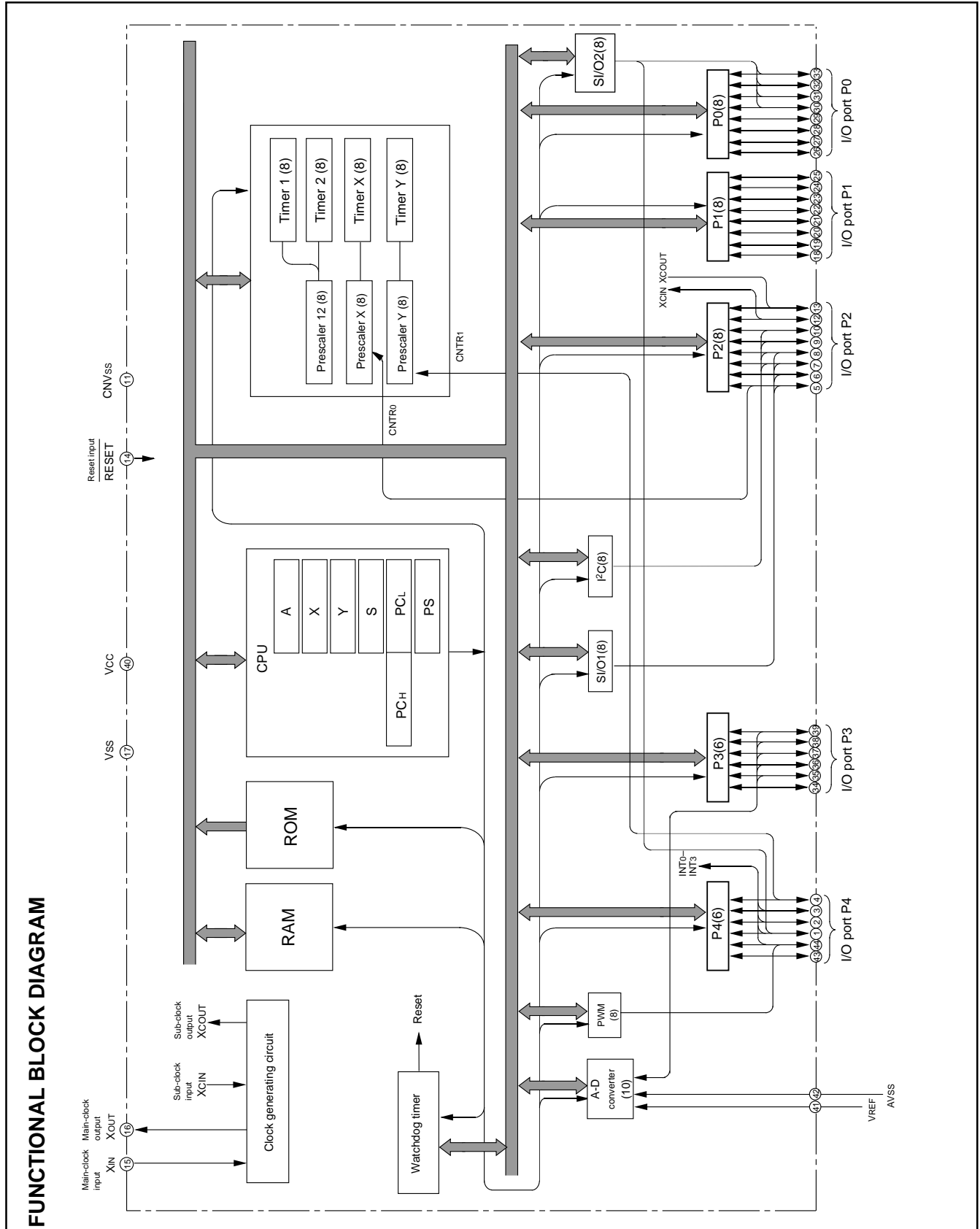

Fig.2 Functional block diagram

Table 1 Pin description

Pin	Name	Functions	
			Function except a port function
VCC, VSS	Power source	•Apply voltage of 2.7 V – 5.5 V to Vcc, and 0 V to Vss.	
CNVSS	CNVSS input	•This pin controls the operation mode of the chip. •Normally connected to Vss.	
VREF	Reference voltage input	•Reference voltage input pin for A-D converter.	
AVss	Analog power source input	•Analog power source input pin for A-D converter. •Connect to Vss.	
RESET	Reset input	•Reset input pin for active “L”.	
XIN	Clock input	•Input and output pins for the clock generating circuit. •Connect a ceramic resonator or quartz-crystal oscillator between the XIN and XOUT pins to set the oscillation frequency.	
XOUT	Clock output	•When an external clock is used, connect the clock source to the XIN pin and leave the XOUT pin open.	
P00/SIN2 P01/SOUT2 P02/SCLK2 P03/SRDY2 P04–P07	I/O port P0	•8-bit CMOS I/O port. •I/O direction register allows each pin to be individually programmed as either input or output. •CMOS compatible input level.	• Serial I/O2 function pin
P10–P17	I/O port P1	•CMOS 3-state output structure. •P10 to P17 (8 bits) are enabled to output large current for LED drive.	
P20/XCOUT P21/XCIN P22/SDA1 P23/SCL1 P24/SDA2/RxD P25/SCL2/TxD P26/SCLK P27/CNTR0/ SRDY1	I/O port P2	•8-bit CMOS I/O port. •I/O direction register allows each pin to be individually programmed as either input or output. •CMOS compatible input level. •P22 to P25 can be switched between CMOS compatible input level or SMBUS input level in the I <sup>2</sup> C-BUS interface function. •P20, P21, P24 to P27: CMOS 3-state output structure. •P24, P25: N-channel open-drain structure in the I <sup>2</sup> C-BUS interface function. •P22, P23: N-channel open-drain structure.	• Sub-clock generating circuit I/O pins (connect a resonator) • I <sup>2</sup> C-BUS interface function pins • I <sup>2</sup> C-BUS interface function pin/ Serial I/O1 function pins • Serial I/O1 function pin • Serial I/O1 function pin/ Timer X function pin
P30/AN0– P35/AN5	I/O port P3	•8-bit CMOS I/O port with the same function as port P0. •CMOS compatible input level. •CMOS 3-state output structure.	• A-D converter input pin
P40/CNTR1 P41/INT0 P42/INT1 P43/INT2/SCMP2 P44/INT3/PWM P45	I/O port P4	•8-bit CMOS I/O port with the same function as port P0. •CMOS compatible input level. •CMOS 3-state output structure.	• Timer Y function pin • Interrupt input pins • Interrupt input pin/SCMP2 output pin • Interrupt input pin/PWM output pin

**PART NUMBERING**

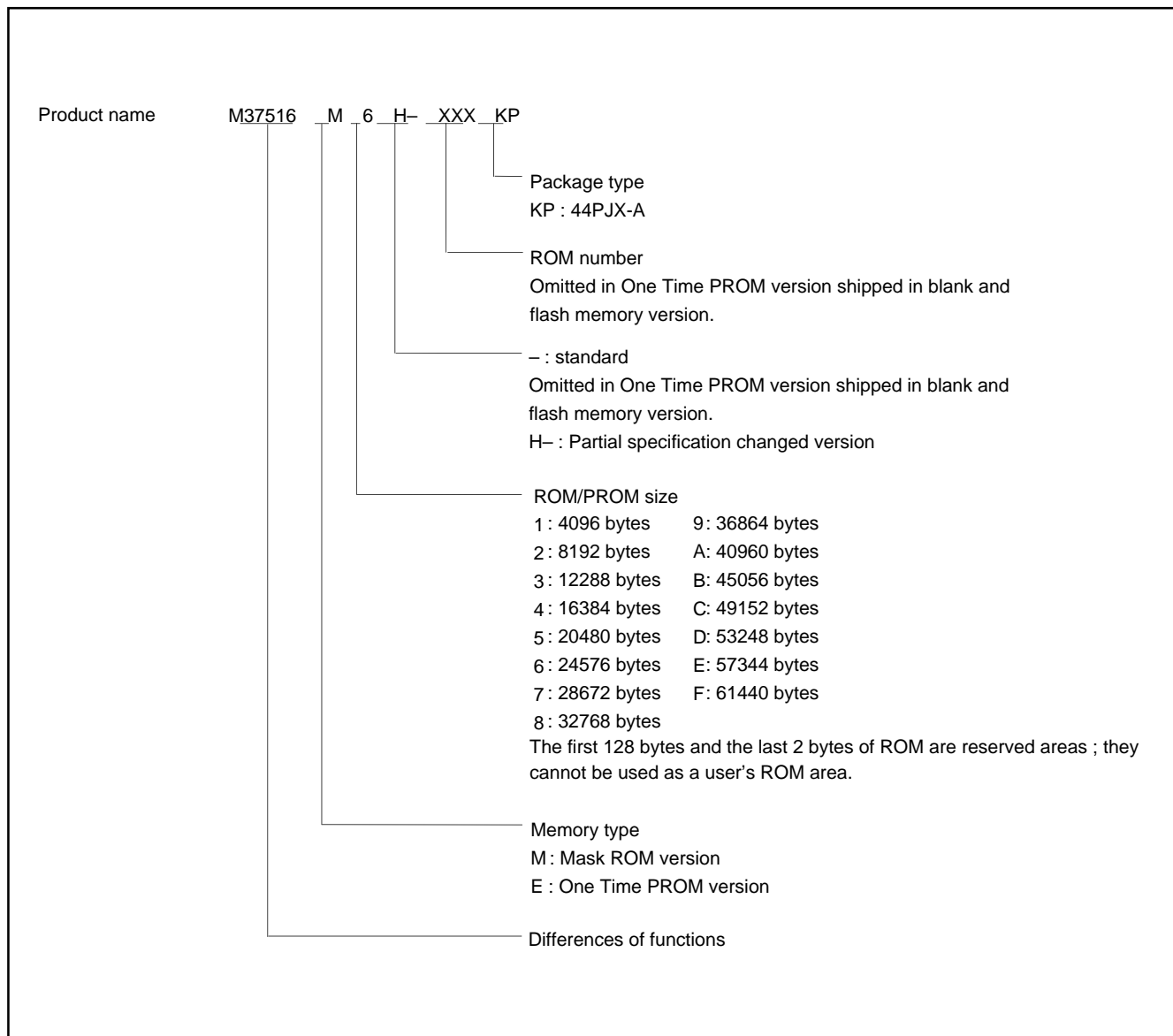

Fig. 3 Part numbering

**GROUP EXPANSION**

Mitsubishi plans to expand the 7516 group (Spec. H) as follows.

**Memory Type**

Support for mask ROM and One Time PROM versions.

**Memory Size**

Mask ROM size ..... 16 K to 24 K bytes

One Time PROM size ..... 24 K bytes

RAM size ..... 512 to 640 bytes

**Packages**

44PJX-A ..... 44-pin plastic-molded QFN

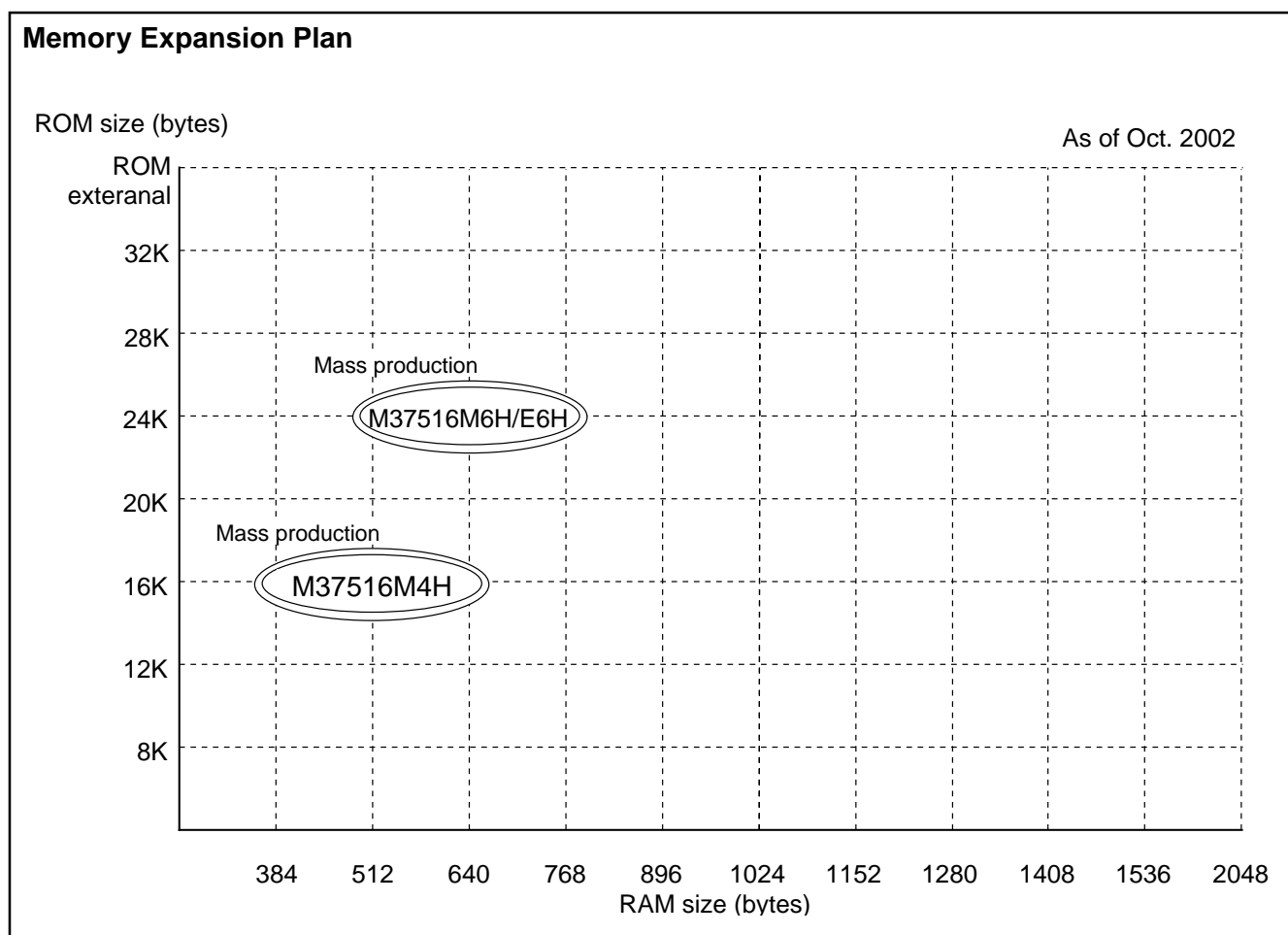

Fig. 4 Memory expansion plan

# 7516 Group (Spec. H)

SINGLE-CHIP 8-BIT CMOS MICROCOMPUTER

Currently planning products are listed below.

**Table 2 Support products**

As of Oct. 2002

Product name	ROM size (bytes) ROM size for User in ( )	RAM size (bytes)	Package	Remarks
M37516M4H-XXXKP	16384 (16254)	512	44PJX-A	Mask ROM version
M37516M6H-XXXKP	24576 (24446)	640		
M37516E6HKP				One Time PROM version (blank)

**FUNCTIONAL DESCRIPTION  
CENTRAL PROCESSING UNIT (CPU)**

The 7516 group (Spec. H) uses the standard 740 Family instruction set. Refer to the table of 740 Family addressing modes and machine instructions or the 740 Family Software Manual for details on the instruction set.

Machine-resident 740 Family instructions are as follows:

- The FST and SLW instructions cannot be used.
- The STP, WIT, MUL, and DIV instructions can be used.

**[Accumulator (A)]**

The accumulator is an 8-bit register. Data operations such as data transfer, etc., are executed mainly through the accumulator.

**[Index Register X (X)]**

The index register X is an 8-bit register. In the index addressing modes, the value of the OPERAND is added to the contents of register X and specifies the real address.

**[Index Register Y (Y)]**

The index register Y is an 8-bit register. In partial instruction, the value of the OPERAND is added to the contents of register Y and specifies the real address.

**[Stack Pointer (S)]**

The stack pointer is an 8-bit register used during subroutine calls and interrupts. This register indicates start address of stored area (stack) for storing registers during subroutine calls and interrupts. The low-order 8 bits of the stack address are determined by the contents of the stack pointer. The high-order 8 bits of the stack address are determined by the stack page selection bit. If the stack page selection bit is "0", the high-order 8 bits becomes "0016". If the stack page selection bit is "1", the high-order 8 bits becomes "0116".

The operations of pushing register contents onto the stack and popping them from the stack are shown in Figure 6.

Store registers other than those described in Figure 6 with program when the user needs them during interrupts or subroutine calls.

**[Program Counter (PC)]**

The program counter is a 16-bit counter consisting of two 8-bit registers PCH and PCL. It is used to indicate the address of the next instruction to be executed.

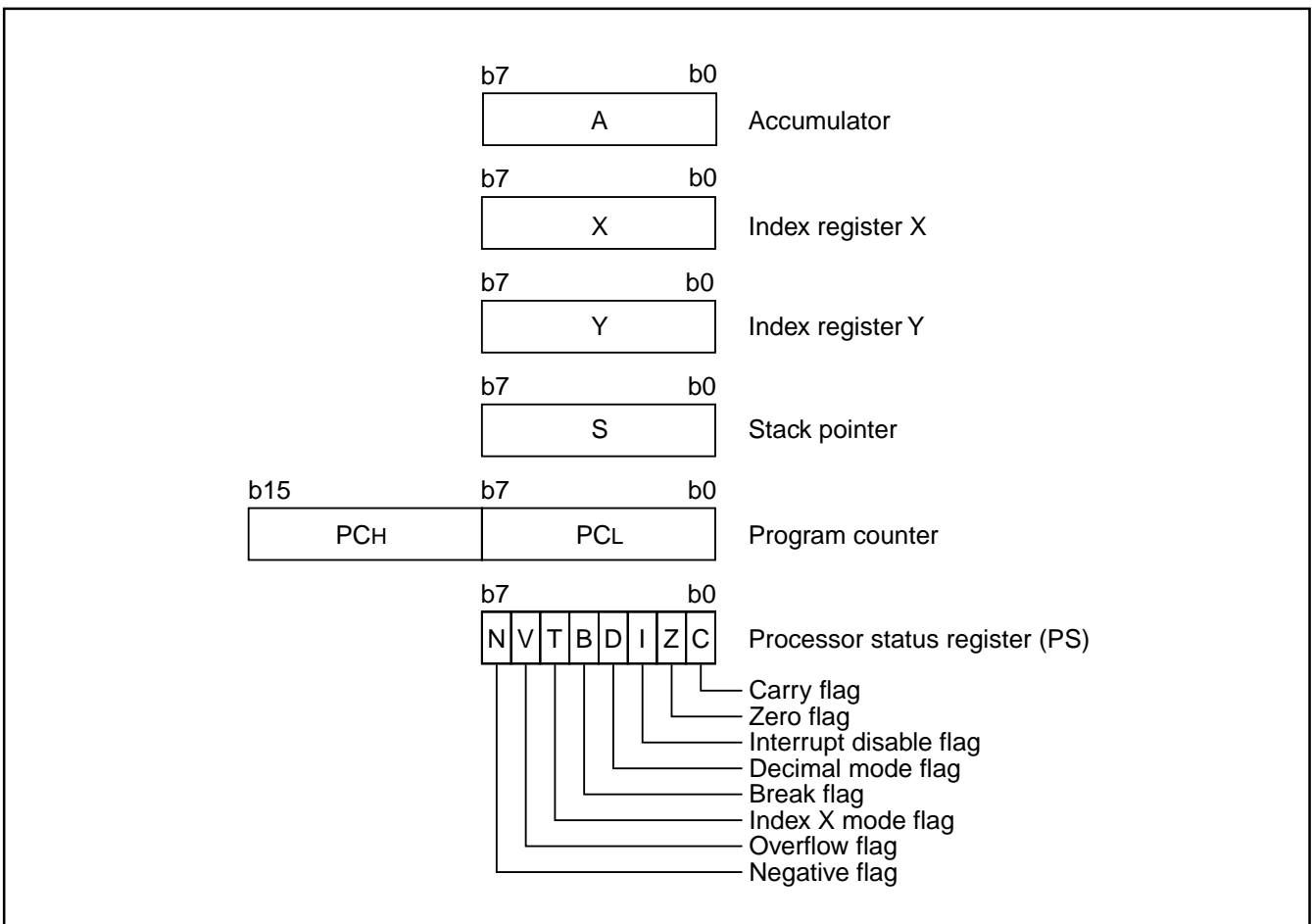

Fig. 5 740 Family CPU register structure



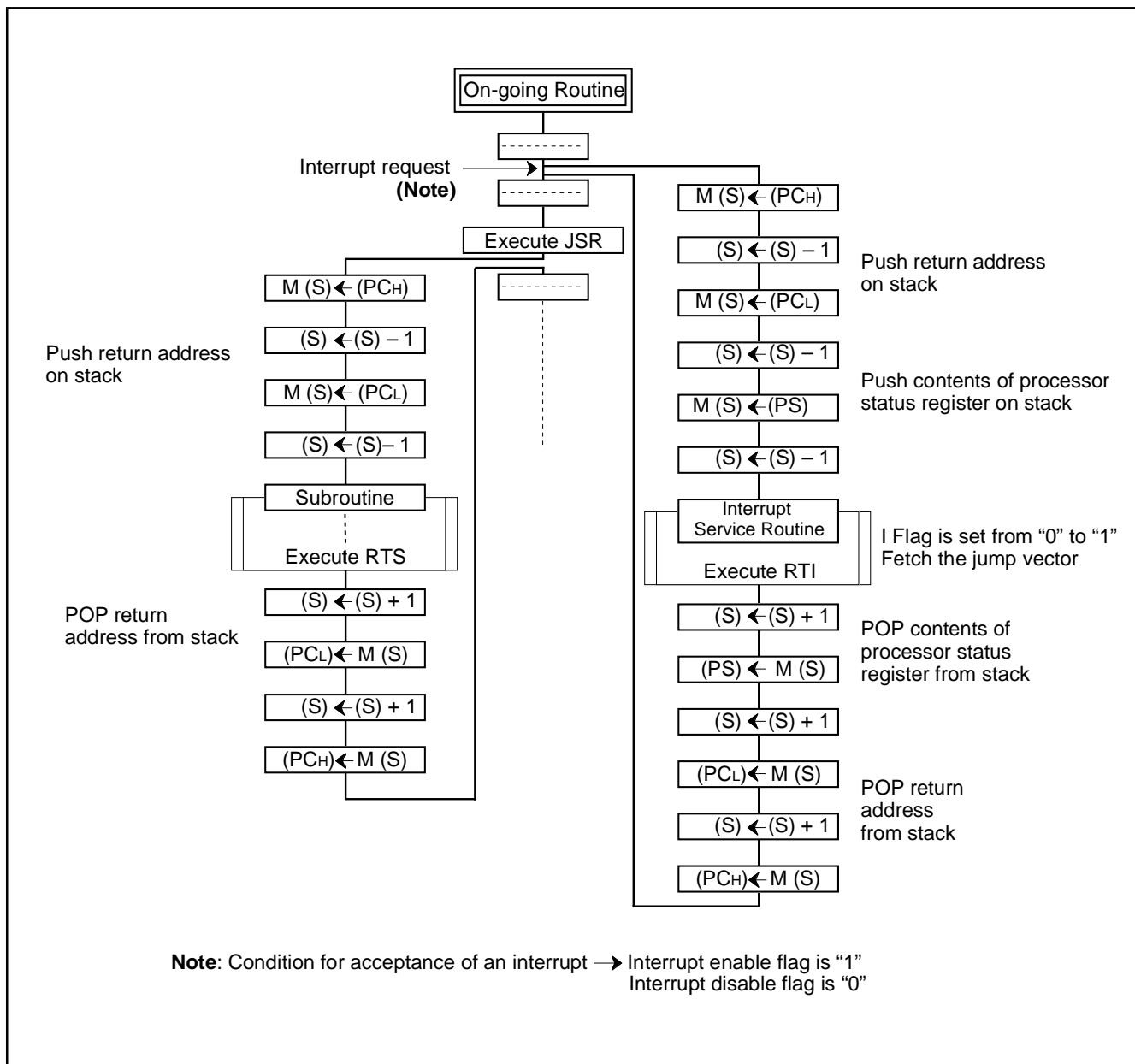

Fig. 6 Register push and pop at interrupt generation and subroutine call

Table 3 Push and pop instructions of accumulator or processor status register

	Push instruction to stack	Pop instruction from stack
Accumulator	PHA	PLA
Processor status register	PHP	PLP

**[Processor status register (PS)]**

The processor status register is an 8-bit register consisting of 5 flags which indicate the status of the processor after an arithmetic operation and 3 flags which decide MCU operation. Branch operations can be performed by testing the Carry (C) flag, Zero (Z) flag, Overflow (V) flag, or the Negative (N) flag. In decimal mode, the Z, V, N flags are not valid.

•Bit 0: Carry flag (C)

The C flag contains a carry or borrow generated by the arithmetic logic unit (ALU) immediately after an arithmetic operation. It can also be changed by a shift or rotate instruction.

•Bit 1: Zero flag (Z)

The Z flag is set if the result of an immediate arithmetic operation or a data transfer is "0", and cleared if the result is anything other than "0".

•Bit 2: Interrupt disable flag (I)

The I flag disables all interrupts except for the interrupt generated by the BRK instruction.

Interrupts are disabled when the I flag is "1".

•Bit 3: Decimal mode flag (D)

The D flag determines whether additions and subtractions are executed in binary or decimal. Binary arithmetic is executed when this flag is "0"; decimal arithmetic is executed when it is "1". Decimal correction is automatic in decimal mode. Only the ADC and SBC instructions can be used for decimal arithmetic.

•Bit 4: Break flag (B)

The B flag is used to indicate that the current interrupt was generated by the BRK instruction. The BRK flag in the processor status register is always "0". When the BRK instruction is used to generate an interrupt, the processor status register is pushed onto the stack with the break flag set to "1".

•Bit 5: Index X mode flag (T)

When the T flag is "0", arithmetic operations are performed between accumulator and memory. When the T flag is "1", direct arithmetic operations and direct data transfers are enabled between memory locations.

•Bit 6: Overflow flag (V)

The V flag is used during the addition or subtraction of one byte of signed data. It is set if the result exceeds +127 to -128. When the BIT instruction is executed, bit 6 of the memory location operated on by the BIT instruction is stored in the overflow flag.

•Bit 7: Negative flag (N)

The N flag is set if the result of an arithmetic operation or data transfer is negative. When the BIT instruction is executed, bit 7 of the memory location operated on by the BIT instruction is stored in the negative flag.

**Table 4 Set and clear instructions of each bit of processor status register**

	C flag	Z flag	I flag	D flag	B flag	T flag	V flag	N flag
Set instruction	SEC	–	SEI	SED	–	SET	–	–
Clear instruction	CLC	–	CLI	CLD	–	CLT	CLV	–

**[CPU Mode Register (CPUM)] 003B16**

The CPU mode register contains the stack page selection bit, etc.

The CPU mode register is allocated at address 003B16.

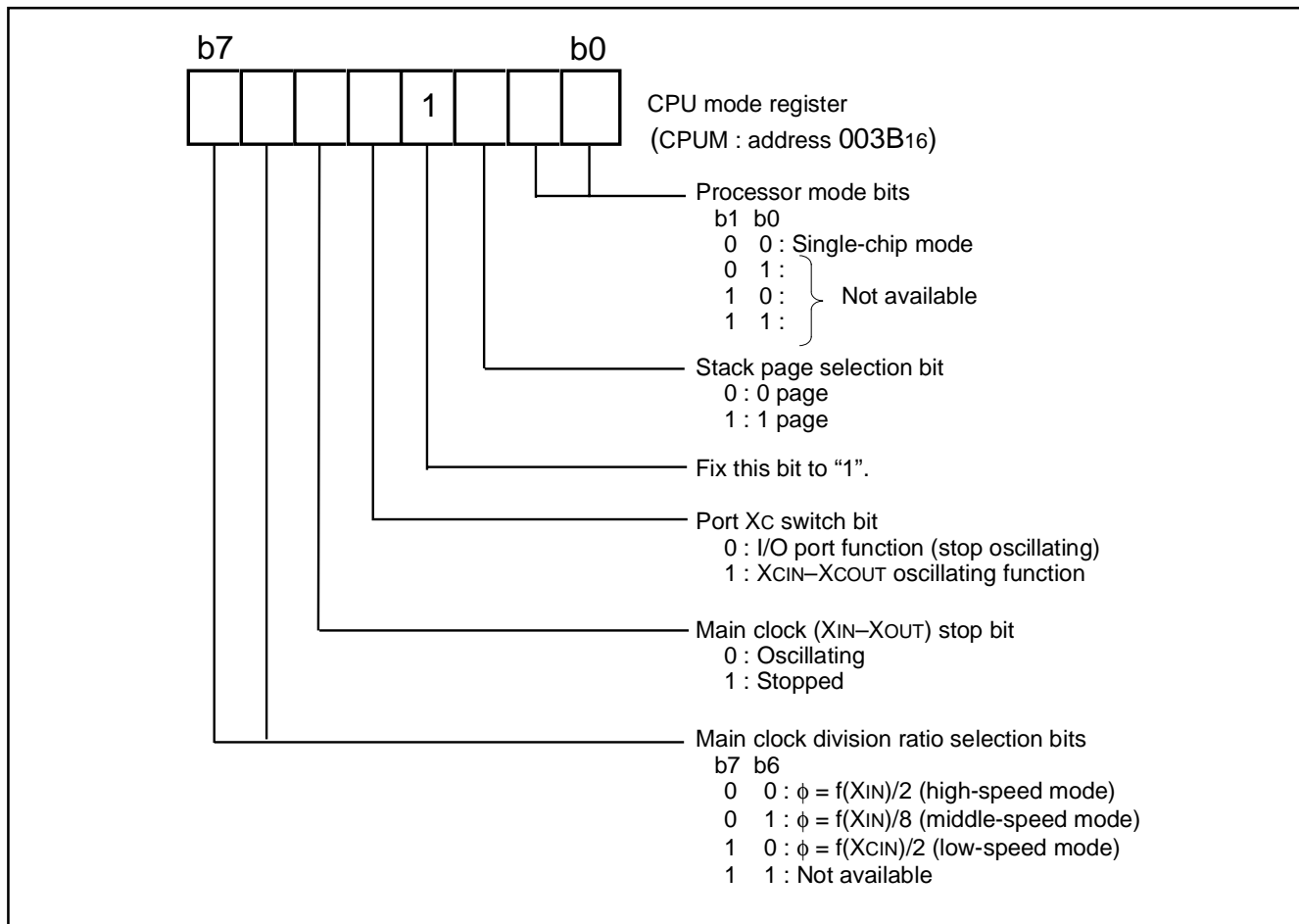

Fig. 7 Structure of CPU mode register

**MEMORY**

**Special Function Register (SFR) Area**

The Special Function Register area in the zero page contains control registers such as I/O ports and timers.

**RAM**

RAM is used for data storage and for stack area of subroutine calls and interrupts.

**ROM**

The first 128 bytes and the last 2 bytes of ROM are reserved for device testing and the rest is user area for storing programs.

**Interrupt Vector Area**

The interrupt vector area contains reset and interrupt vectors.

**Zero Page**

Access to this area with only 2 bytes is possible in the zero page addressing mode.

**Special Page**

Access to this area with only 2 bytes is possible in the special page addressing mode.

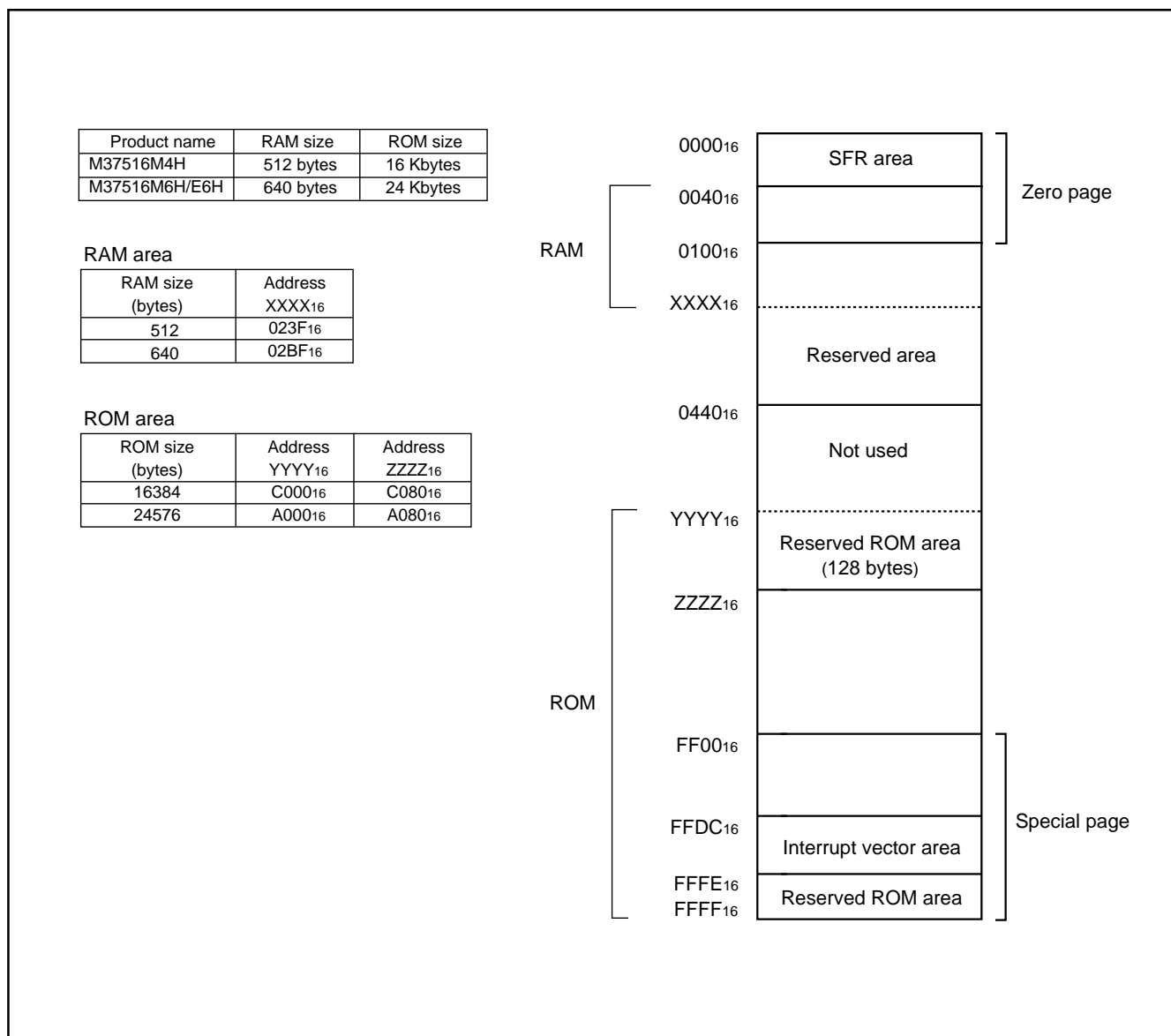

Fig. 8 Memory map diagram

0000 <sub>16</sub>	Port P0 (P0)	0020 <sub>16</sub>	Prescaler 12 (PRE12)
0001 <sub>16</sub>	Port P0 direction register (P0D)	0021 <sub>16</sub>	Timer 1 (T1)
0002 <sub>16</sub>	Port P1 (P1)	0022 <sub>16</sub>	Timer 2 (T2)
0003 <sub>16</sub>	Port P1 direction register (P1D)	0023 <sub>16</sub>	Timer XY mode register (TM)
0004 <sub>16</sub>	Port P2 (P2)	0024 <sub>16</sub>	Prescaler X (PREX)
0005 <sub>16</sub>	Port P2 direction register (P2D)	0025 <sub>16</sub>	Timer X (TX)
0006 <sub>16</sub>	Port P3 (P3)	0026 <sub>16</sub>	Prescaler Y (PREY)
0007 <sub>16</sub>	Port P3 direction register (P3D)	0027 <sub>16</sub>	Timer Y (TY)
0008 <sub>16</sub>	Port P4 (P4)	0028 <sub>16</sub>	Timer count source selection register (TCSS)
0009 <sub>16</sub>	Port P4 direction register (P4D)	0029 <sub>16</sub>	
000A <sub>16</sub>		002A <sub>16</sub>	
000B <sub>16</sub>		002B <sub>16</sub>	I <sup>2</sup> C data shift register (S0)
000C <sub>16</sub>		002C <sub>16</sub>	I <sup>2</sup> C address register (S0D)
000D <sub>16</sub>		002D <sub>16</sub>	I <sup>2</sup> C status register (S1)
000E <sub>16</sub>		002E <sub>16</sub>	I <sup>2</sup> C control register (S1D)
000F <sub>16</sub>		002F <sub>16</sub>	I <sup>2</sup> C clock control register (S2)
0010 <sub>16</sub>		0030 <sub>16</sub>	I <sup>2</sup> C start/stop condition control register (S2D)
0011 <sub>16</sub>		0031 <sub>16</sub>	Reserved *
0012 <sub>16</sub>	Reserved *	0032 <sub>16</sub>	
0013 <sub>16</sub>	Reserved *	0033 <sub>16</sub>	
0014 <sub>16</sub>	Reserved *	0034 <sub>16</sub>	A-D control register (ADCON)
0015 <sub>16</sub>	Serial I/O2 control register 1 (SIO2CON1)	0035 <sub>16</sub>	A-D conversion low-order register (ADL)
0016 <sub>16</sub>	Serial I/O2 control register 2 (SIO2CON2)	0036 <sub>16</sub>	A-D conversion high-order register (ADH)
0017 <sub>16</sub>	Serial I/O2 register (SIO2)	0037 <sub>16</sub>	
0018 <sub>16</sub>	Transmit/Receive buffer register (TB/RB)	0038 <sub>16</sub>	MISRG
0019 <sub>16</sub>	Serial I/O1 status register (SIOSTS)	0039 <sub>16</sub>	Watchdog timer control register (WDTCN)
001A <sub>16</sub>	Serial I/O1 control register (SIOCON)	003A <sub>16</sub>	Interrupt edge selection register (INTEDGE)
001B <sub>16</sub>	UART control register (UARTCON)	003B <sub>16</sub>	CPU mode register (CPUM)
001C <sub>16</sub>	Baud rate generator (BRG)	003C <sub>16</sub>	Interrupt request register 1 (IREQ1)
001D <sub>16</sub>	PWM control register (PWMCON)	003D <sub>16</sub>	Interrupt request register 2 (IREQ2)
001E <sub>16</sub>	PWM prescaler (PREPWM)	003E <sub>16</sub>	Interrupt control register 1 (ICON1)
001F <sub>16</sub>	PWM register (PWM)	003F <sub>16</sub>	Interrupt control register 2 (ICON2)

\* Reserved : Do not write any data to the reserved area.

Fig. 9 Memory map of special function register (SFR)

**I/O PORTS**

The I/O ports have direction registers which determine the input/output direction of each individual pin. Each bit in a direction register corresponds to one pin, and each pin can be set to be input port or output port.

When "0" is written to the bit corresponding to a pin, that pin becomes an input pin. When "1" is written to that bit, that pin becomes an output pin.

If data is read from a pin which is set to output, the value of the port output latch is read, not the value of the pin itself. Pins set to input are floating. If a pin set to input is written to, only the port output latch is written to and the pin remains floating.

**Table 5 I/O port function**

Pin	Name	Input/Output	I/O Structure	Non-Port Function	Related SFRs	Ref.No.
P00/SIN2 P01/SOUT2 P02/SCLK2 P03/SRDY2	Port P0	Input/output, individual bits	CMOS compatible input level CMOS 3-state output	Serial I/O2 function I/O	Serial I/O2 control register	(1)
						(2)
P04-P07						(3)
P10-P17	Port P1					(4)
P20/XCOUT P21/XCIN	Port P2			Sub-clock generating circuit	CPU mode register	(5)
						(6)
P22/SDA1 P23/SCL1			CMOS compatible input level CMOS/SMBUS input level (when selecting I <sup>2</sup> C-BUS interface function) N-channel open-drain output	I <sup>2</sup> C-BUS interface function I/O	I <sup>2</sup> C control register	(7)
						(8)
P24/SDA2/RxD P25/SCL2/TxD			CMOS compatible input level CMOS/SMBUS input level (when selecting I <sup>2</sup> C-BUS interface function) CMOS 3-state output N-channel open-drain output (when selecting I <sup>2</sup> C-BUS interface function)	I <sup>2</sup> C-BUS interface function I/O Serial I/O1 function I/O	I <sup>2</sup> C control register Serial I/O1 control register	(9)
						(10)
P26/SCLK			CMOS compatible input level	Serial I/O1 function I/O	Serial I/O1 control register	(11)
P27/CNTR0/ SRDY1			CMOS 3-state output	Serial I/O1 function I/O Timer X function I/O	Serial I/O1 control register Timer XY mode register	(12)
						(13)
P30/AN0-P35/AN5	Port P3			A-D conversion input	A-D control register	(14)
P40/CNTR1	Port P4			Timer Y function I/O	Timer XY mode register	(15)
P41/INT0 P42/INT1				External interrupt input	Interrupt edge selection register	(16)
P43/INT2/SCMP2				External interrupt input SCMP2 output	Interrupt edge selection register Serial I/O2 control register	(17)
P44/INT3/PWM				External interrupt input PWM output	Interrupt edge selection register PWM control register	(18)
P45						(5)

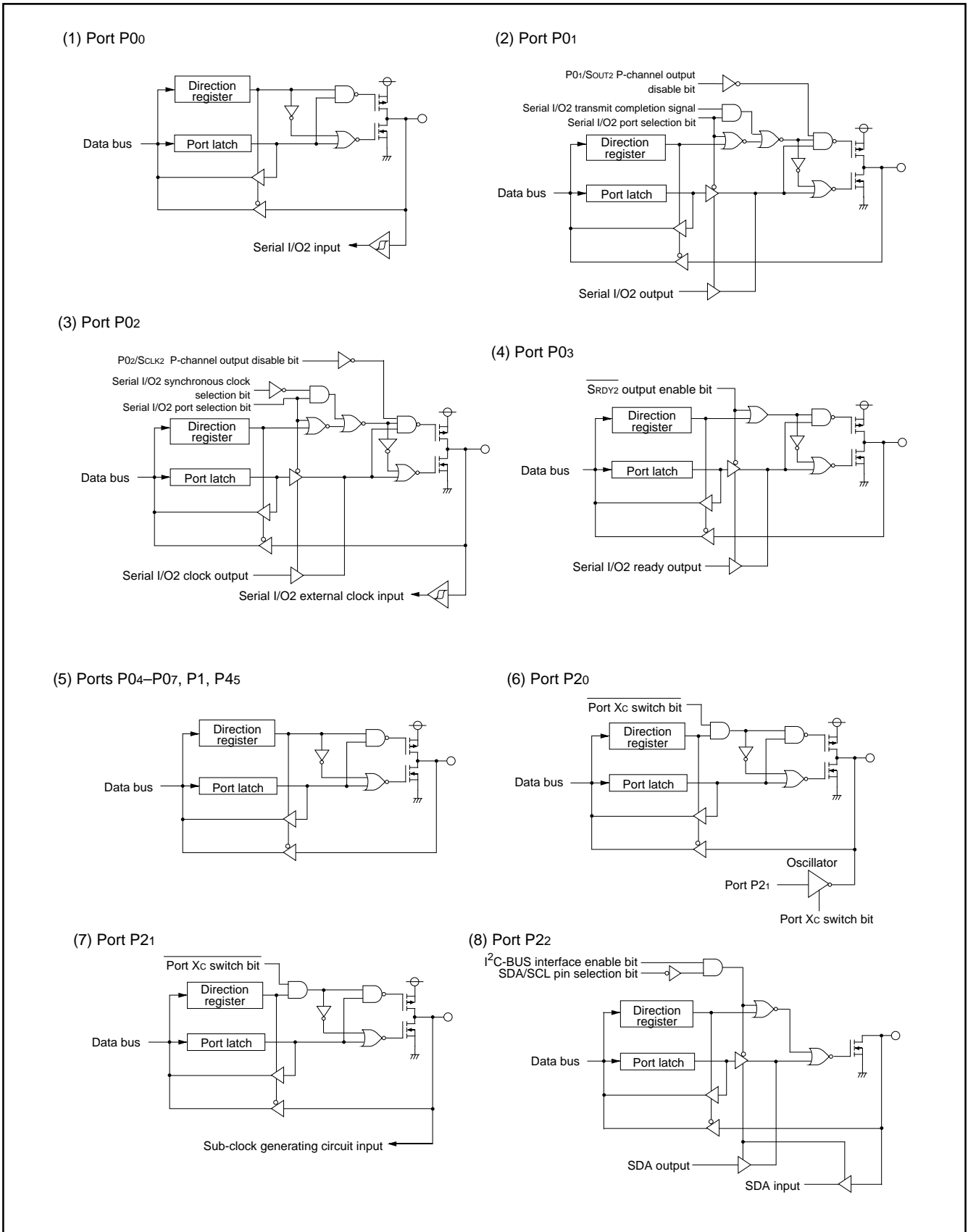

Fig. 10 Port block diagram (1)

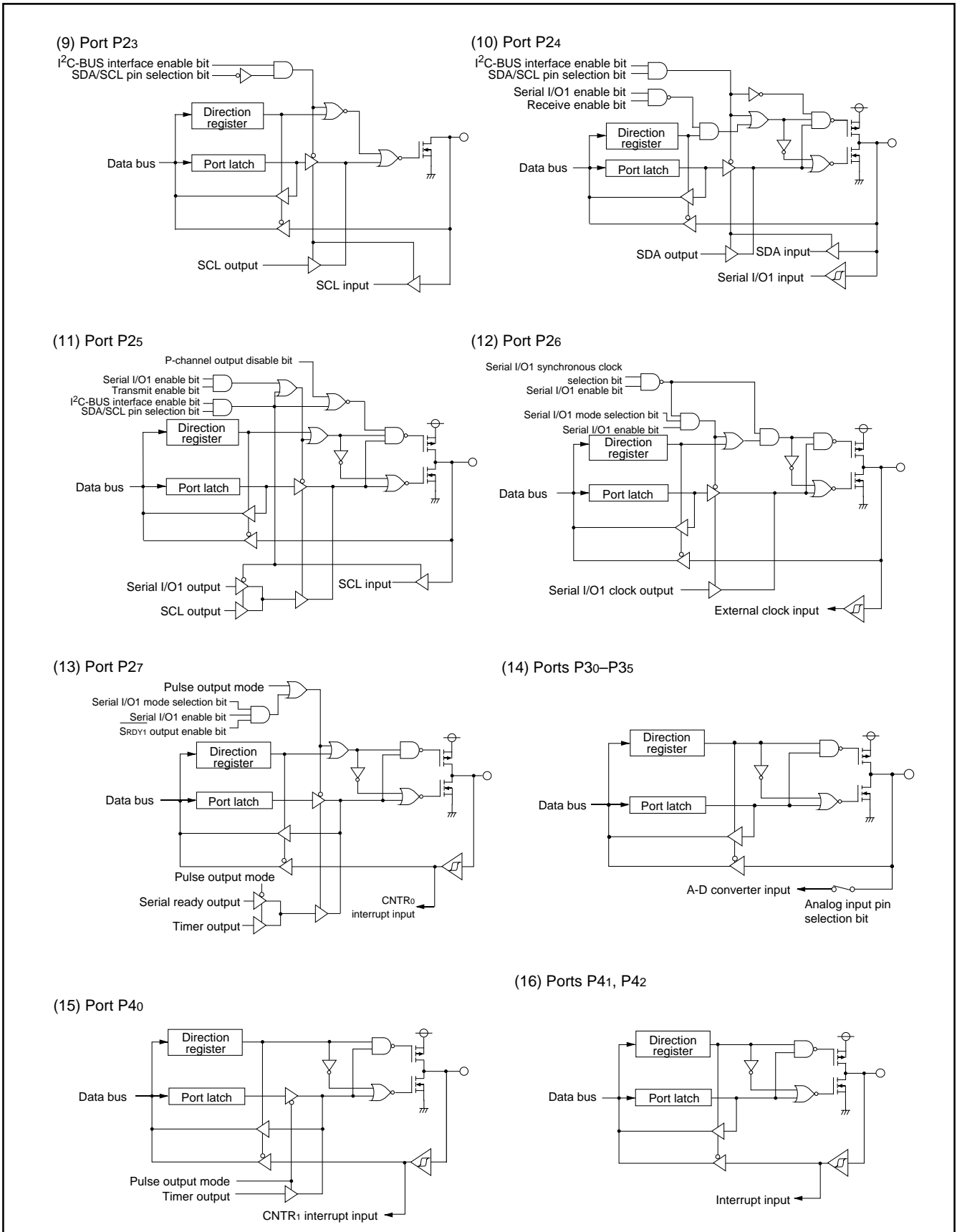

Fig. 11 Port block diagram (2)



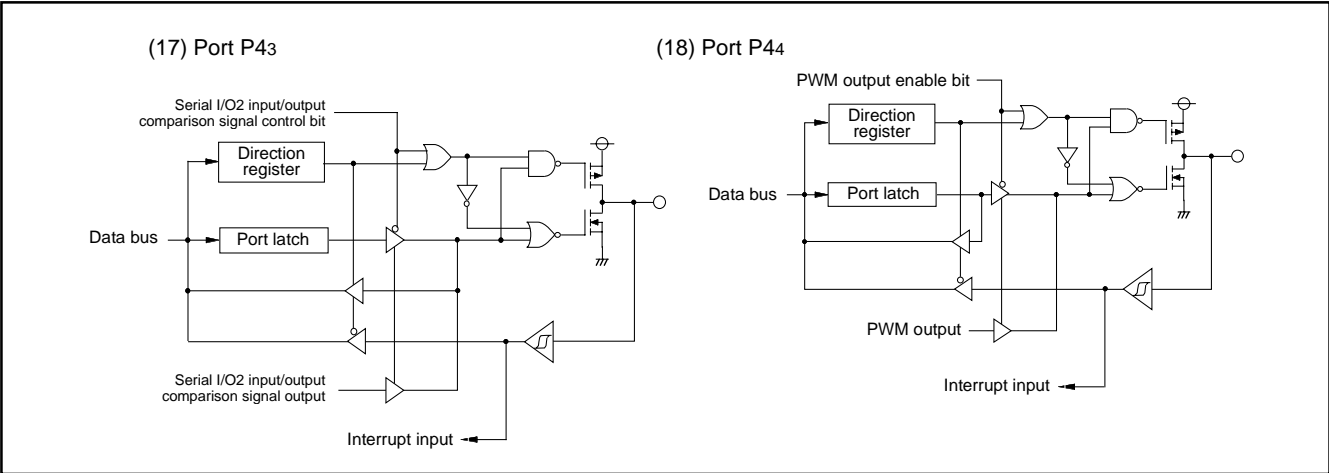

Fig. 12 Port block diagram (3)

## INTERRUPTS

Interrupts occur by 17 sources among 17 sources: seven external, nine internal, and one software.

### Interrupt Control

Each interrupt is controlled by an interrupt request bit, an interrupt enable bit, and the interrupt disable flag except for the software interrupt set by the BRK instruction. An interrupt occurs if the corresponding interrupt request and enable bits are "1" and the interrupt disable flag is "0".

Interrupt enable bits can be set or cleared by software.

Interrupt request bits can be cleared by software, but cannot be set by software.

The BRK instruction cannot be disabled with any flag or bit. The I (interrupt disable) flag disables all interrupts except the BRK instruction interrupt.

When several interrupts occur at the same time, the interrupts are received according to priority.

### Interrupt Operation

By acceptance of an interrupt, the following operations are automatically performed:

1. The contents of the program counter and the processor status register are automatically pushed onto the stack.
2. The interrupt disable flag is set and the corresponding interrupt request bit is cleared.
3. The interrupt jump destination address is read from the vector table into the program counter.

## ■Notes

When setting the followings, the interrupt request bit may be set to "1".

- When setting external interrupt active edge

Related register: Interrupt edge selection register (address 3A16)  
I<sup>2</sup>C start/stop condition control register (address 3016)  
Timer XY mode register (address 2316)

- When switching interrupt sources of an interrupt vector address where two or more interrupt sources are allocated

Related register: Interrupt edge selection register (address 3A16)  
When not requiring for the interrupt occurrence synchronized with these setting, take the following sequence.

- ①Set the corresponding interrupt enable bit to "0" (disabled).
- ②Set the interrupt edge select bit or the interrupt source select bit.
- ③Set the corresponding interrupt request bit to "0" after 1 or more instructions have been executed.
- ④Set the corresponding interrupt enable bit to "1" (enabled).

**Table 6 Interrupt vector addresses and priority**

Interrupt Source	Priority	Vector Addresses (Note 1)		Interrupt Request Generating Conditions	Remarks
		High	Low		
Reset (Note 2)	1	FFFD <sub>16</sub>	FFFC <sub>16</sub>	At reset	Non-maskable
INT <sub>0</sub>	2	FFFB <sub>16</sub>	FFFA <sub>16</sub>	At detection of either rising or falling edge of INT <sub>0</sub> input	External interrupt (active edge selectable)
SCL, SDA	3	FFF9 <sub>16</sub>	FFF8 <sub>16</sub>	At detection of either rising or falling edge of SCL or SDA input	External interrupt (active edge selectable)
INT <sub>1</sub>	4	FFF7 <sub>16</sub>	FFF6 <sub>16</sub>	At detection of either rising or falling edge of INT <sub>1</sub> input	External interrupt (active edge selectable)
INT <sub>2</sub>	5	FFF5 <sub>16</sub>	FFF4 <sub>16</sub>	At detection of either rising or falling edge of INT <sub>2</sub> input	External interrupt (active edge selectable)
INT <sub>3</sub>	6	FFF3 <sub>16</sub>	FFF2 <sub>16</sub>	At detection of either rising or falling edge of INT <sub>3</sub> input	External interrupt (active edge selectable)
Serial I/O <sub>2</sub>				At completion of serial I/O <sub>2</sub> data reception/transmission	Switch by Serial I/O <sub>2</sub> /INT <sub>3</sub> interrupt source bit
I <sup>2</sup> C	7	FFF1 <sub>16</sub>	FFF0 <sub>16</sub>	At completion of data transfer	
Timer X	8	FFEF <sub>16</sub>	FFEE <sub>16</sub>	At timer X underflow	
Timer Y	9	FFED <sub>16</sub>	FFEC <sub>16</sub>	At timer Y underflow	
Timer 1	10	FFEB <sub>16</sub>	FFEA <sub>16</sub>	At timer 1 underflow	STP release timer underflow
Timer 2	11	FFE9 <sub>16</sub>	FFE8 <sub>16</sub>	At timer 2 underflow	
Serial I/O <sub>1</sub> reception	12	FFE7 <sub>16</sub>	FFE6 <sub>16</sub>	At completion of serial I/O <sub>1</sub> data reception	Valid when serial I/O <sub>1</sub> is selected
Serial I/O <sub>1</sub> transmission	13	FFE5 <sub>16</sub>	FFE4 <sub>16</sub>	At completion of serial I/O <sub>1</sub> transfer shift or when transmission buffer is empty	Valid when serial I/O <sub>1</sub> is selected
CNTR <sub>0</sub>	14	FFE3 <sub>16</sub>	FFE2 <sub>16</sub>	At detection of either rising or falling edge of CNTR <sub>0</sub> input	External interrupt (active edge selectable)
CNTR <sub>1</sub>	15	FFE1 <sub>16</sub>	FFE0 <sub>16</sub>	At detection of either rising or falling edge of CNTR <sub>1</sub> input	External interrupt (active edge selectable)
A-D converter	16	FFDF <sub>16</sub>	FFDE <sub>16</sub>	At completion of A-D conversion	
BRK instruction	17	FFDD <sub>16</sub>	FFDC <sub>16</sub>	At BRK instruction execution	Non-maskable software interrupt

**Notes 1:** Vector addresses contain interrupt jump destination addresses.

**2:** Reset function in the same way as an interrupt with the highest priority.

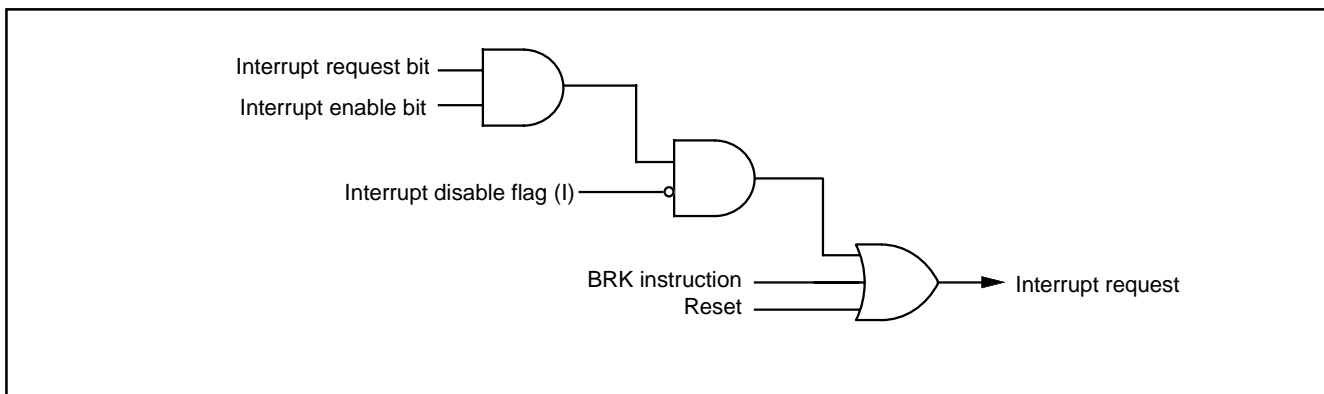

Fig. 13 Interrupt control

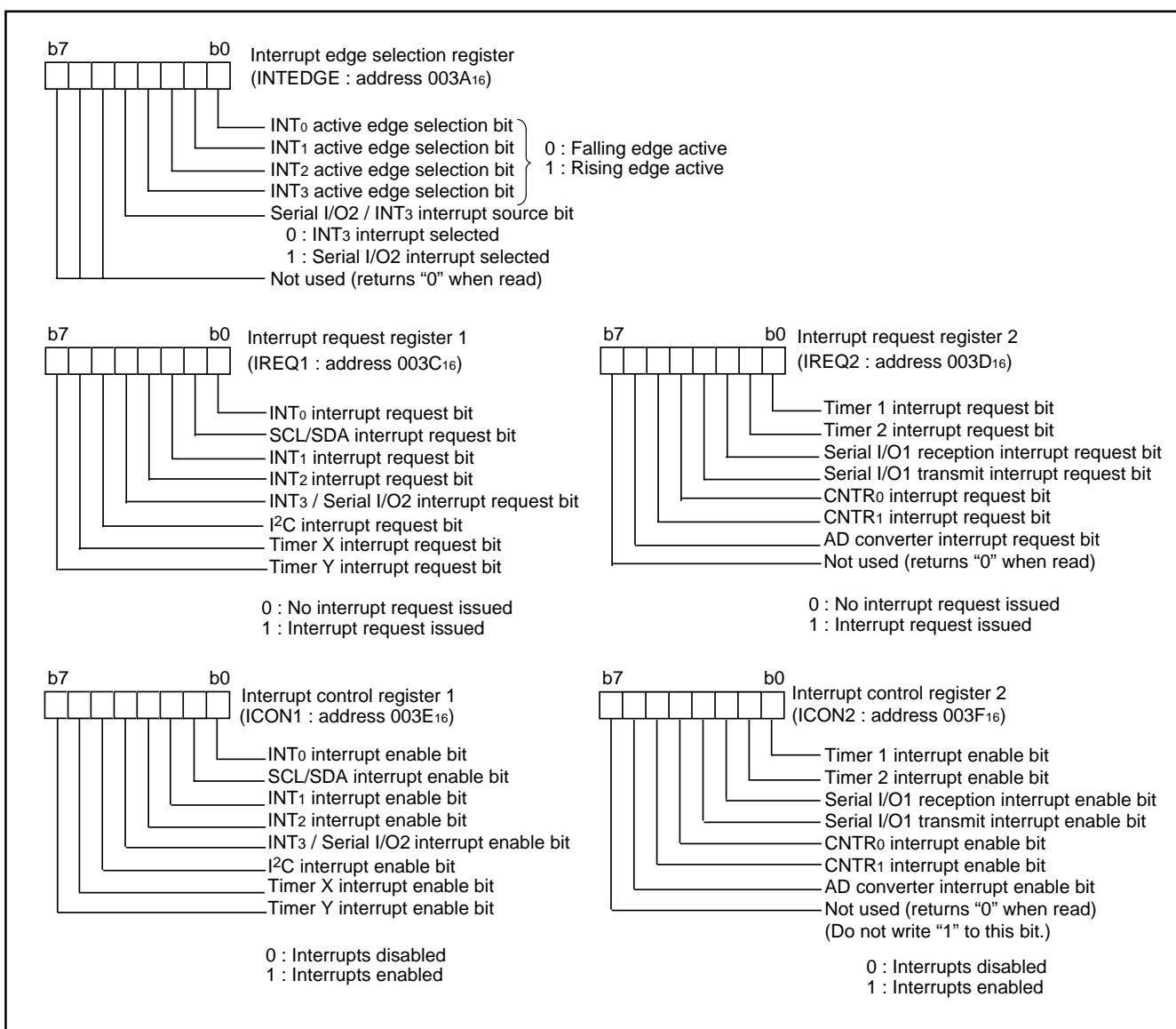

Fig. 14 Structure of interrupt-related registers

**TIMERS**

The 7516 group (Spec. H) has four timers: timer X, timer Y, timer 1, and timer 2.

The division ratio of each timer or prescaler is given by  $1/(n + 1)$ , where n is the value in the corresponding timer or prescaler latch. All timers are count down. When the timer reaches "0016", an underflow occurs at the next count pulse and the corresponding timer latch is reloaded into the timer and the count is continued. When a timer underflows, the interrupt request bit corresponding to that timer is set to "1".

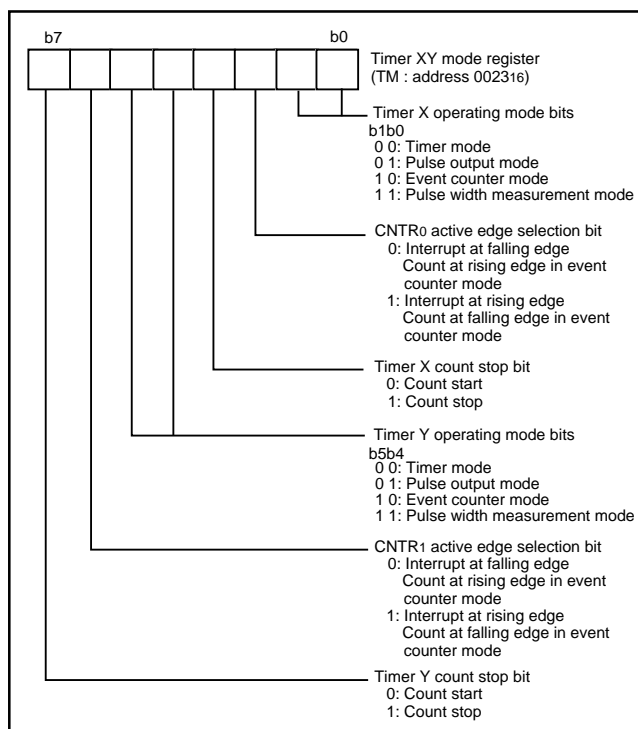

Fig. 15 Structure of timer XY mode register

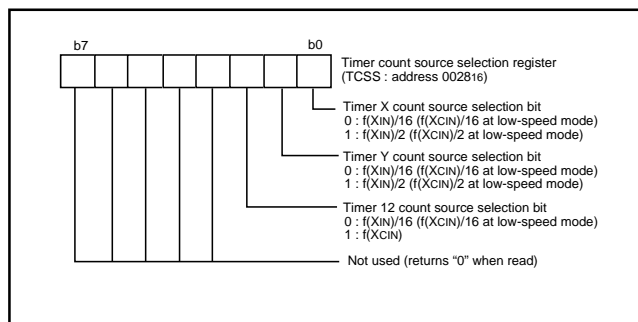

Fig. 16 Structure of timer count source selection register

**Timer 1 and Timer 2**

The count source of prescaler 12 is the oscillation frequency which is selected by timer 12 count source selection bit. The output of prescaler 12 is counted by timer 1 and timer 2, and a timer underflow sets the interrupt request bit.

**Timer X and Timer Y**

Timer X and Timer Y can each select in one of four operating modes by setting the timer XY mode register.

**(1) Timer Mode**

The timer counts the count source selected by Timer count source selection bit.

**(2) Pulse Output Mode**

The timer counts the count source selected by Timer count source selection bit. Whenever the contents of the timer reach "0016", the signal output from the CNTR0 (or CNTR1) pin is inverted. If the CNTR0 (or CNTR1) active edge selection bit is "0", output begins at "H".

If it is "1", output starts at "L". When using a timer in this mode, set the corresponding port P27 ( or port P40) direction register to output mode.

**(3) Event Counter Mode**

Operation in event counter mode is the same as in timer mode, except that the timer counts signals input through the CNTR0 or CNTR1 pin.

When the CNTR0 (or CNTR1) active edge selection bit is "0", the rising edge of the CNTR0 (or CNTR1) pin is counted.

When the CNTR0 (or CNTR1) active edge selection bit is "1", the falling edge of the CNTR0 (or CNTR1) pin is counted.

**(4) Pulse Width Measurement Mode**

If the CNTR0 (or CNTR1) active edge selection bit is "0", the timer counts the selected signals by the count source selection bit while the CNTR0 (or CNTR1) pin is at "H". If the CNTR0 (or CNTR1) active edge selection bit is "1", the timer counts it while the CNTR0 (or CNTR1) pin is at "L".

The count can be stopped by setting "1" to the timer X (or timer Y) count stop bit in any mode. The corresponding interrupt request bit is set each time a timer underflows.

**Note**

When switching the count source by the timer 12, X and Y count source bits, the value of timer count is altered in unconsiderable amount owing to generating of a thin pulses in the count input signals.

Therefore, select the timer count source before set the value to the prescaler and the timer.

When timer X/timer Y underflow while executing the instruction which sets "1" to the timer X/timer Y count stop bits, the timer X/timer Y interrupt request bits are set to "1". Timer X/Timer Y interrupts are received if these interrupts are enabled at this time.

The timing which interrupt is accepted has a case after the instruction which sets "1" to the count stop bit, and a case after the next instruction according to the timing of the timer underflow. When this interrupt is unnecessary, set "0" (disabled) to the interrupt enable bit and then set "1" to the count stop bit.

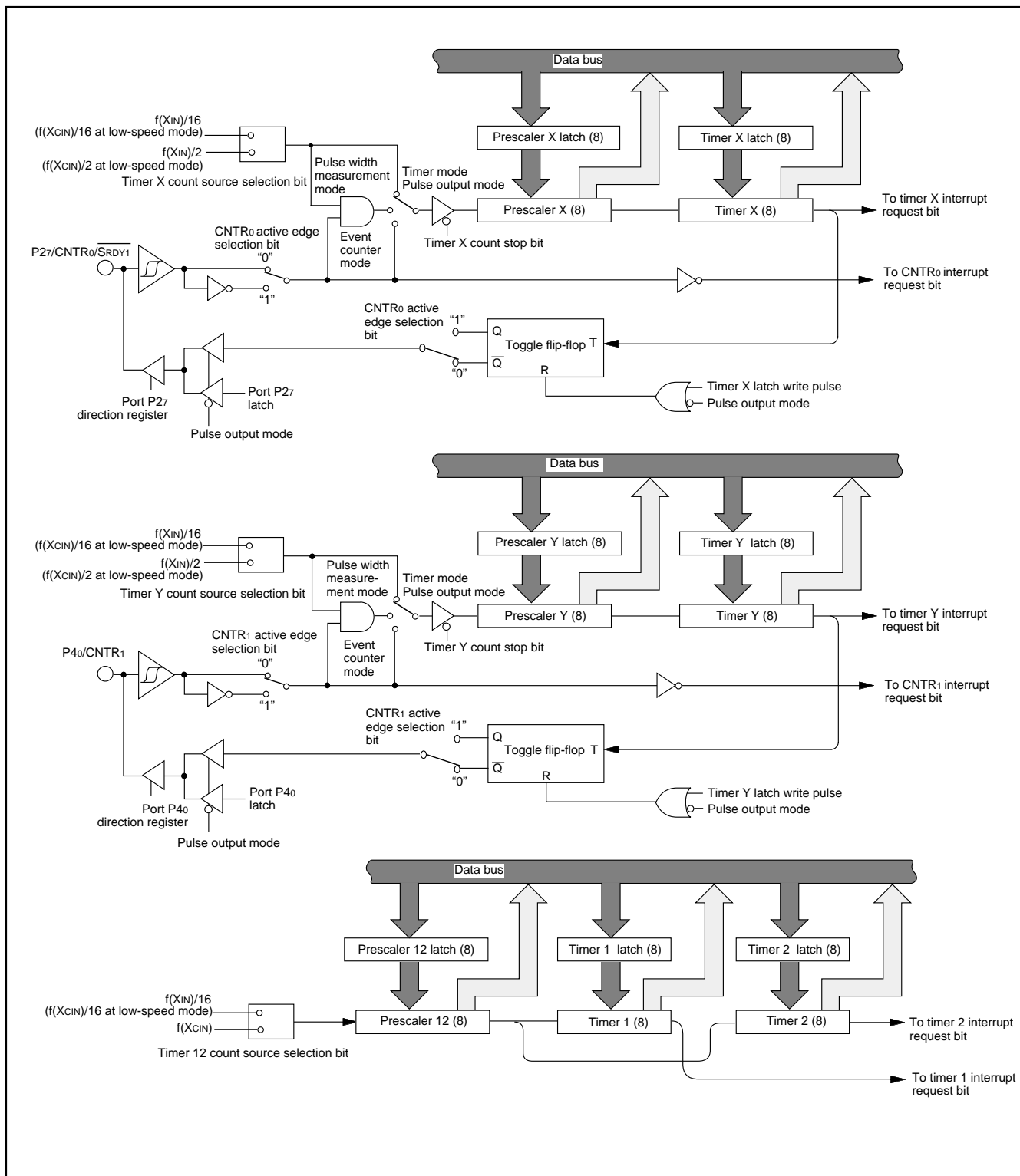

Fig. 17 Block diagram of timer X, timer Y, timer 1, and timer 2

**SERIAL I/O**  
**●SERIAL I/O1**

Serial I/O1 can be used as either clock synchronous or asynchronous (UART) serial I/O. A dedicated timer is also provided for baud rate generation.

**(1) Clock Synchronous Serial I/O Mode**

Clock synchronous serial I/O mode can be selected by setting the serial I/O1 mode selection bit of the serial I/O1 control register (bit 6 of address 001A16) to "1".

For clock synchronous serial I/O, the transmitter and the receiver must use the same clock. If an internal clock is used, transfer is started by a write signal to the TB/RB.

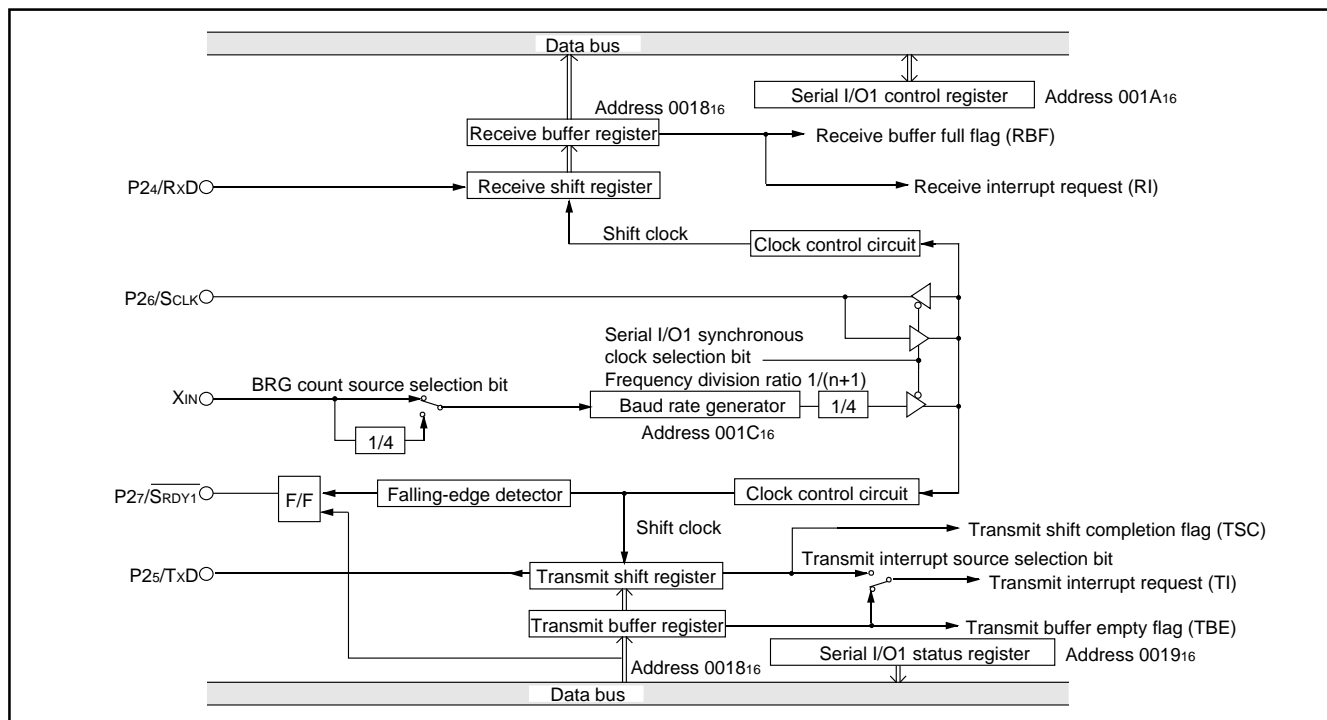

Fig. 18 Block diagram of clock synchronous serial I/O1

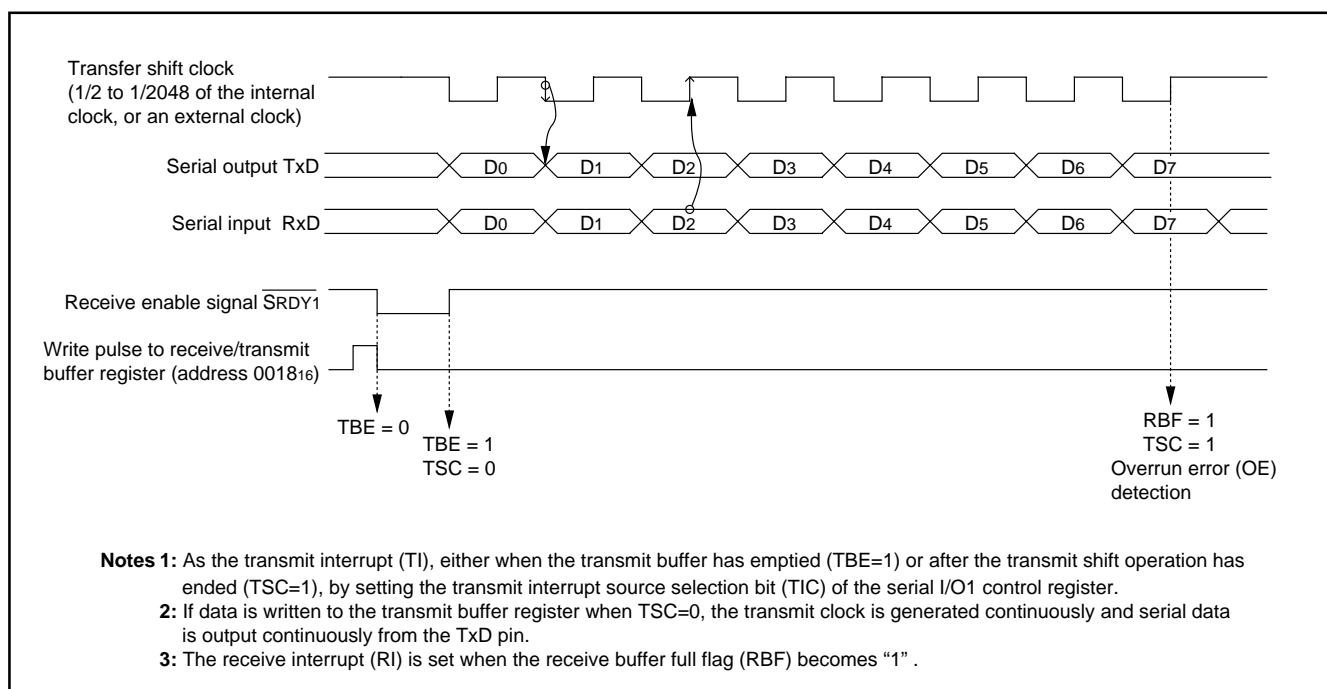

Fig. 19 Operation of clock synchronous serial I/O1 function

## (2) Asynchronous Serial I/O (UART) Mode

Clock asynchronous serial I/O mode (UART) can be selected by clearing the serial I/O1 mode selection bit (b6) of the serial I/O1 control register to "0".

Eight serial data transfer formats can be selected, and the transfer formats used by a transmitter and receiver must be identical.

The transmit and receive shift registers each have a buffer, but the

two buffers have the same address in memory. Since the shift register cannot be written to or read from directly, transmit data is written to the transmit buffer register, and receive data is read from the receive buffer register.

The transmit buffer register can also hold the next data to be transmitted, and the receive buffer register can hold a character while the next character is being received.

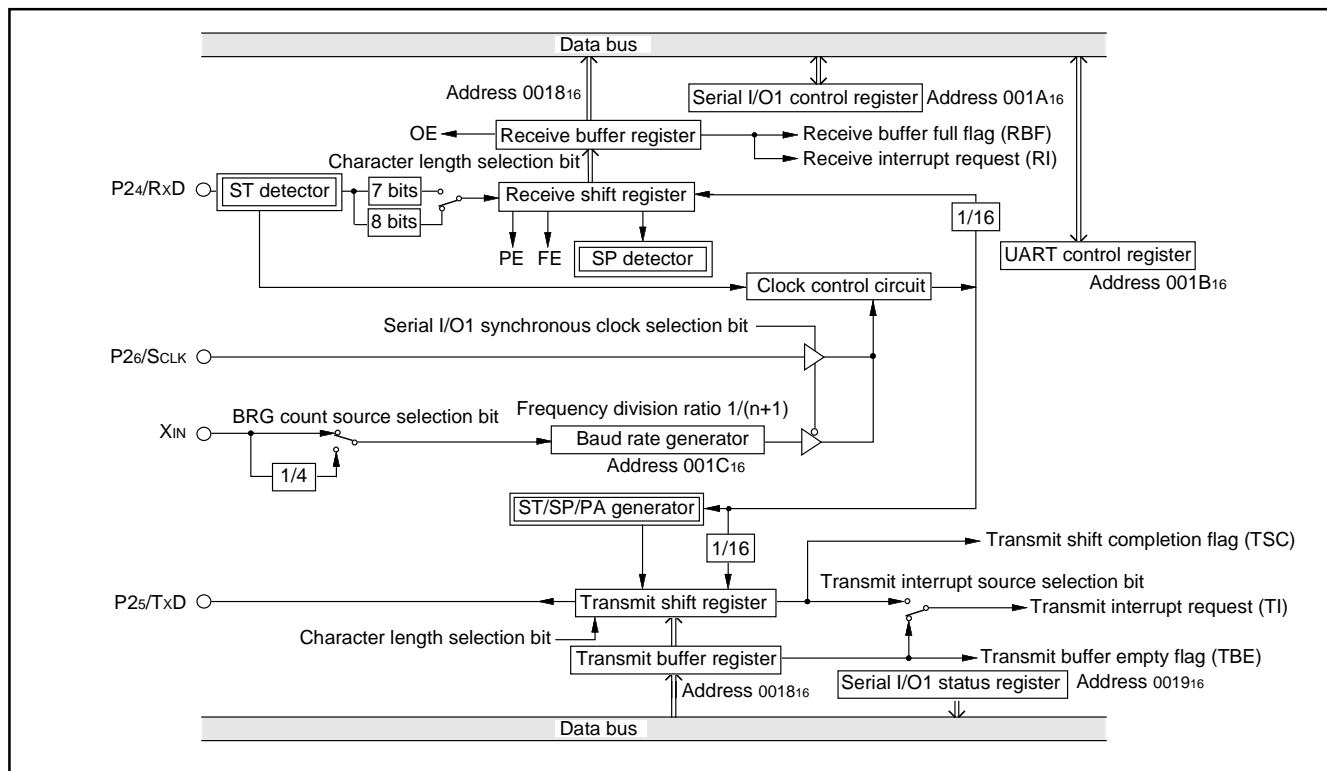

Fig. 20 Block diagram of UART serial I/O1



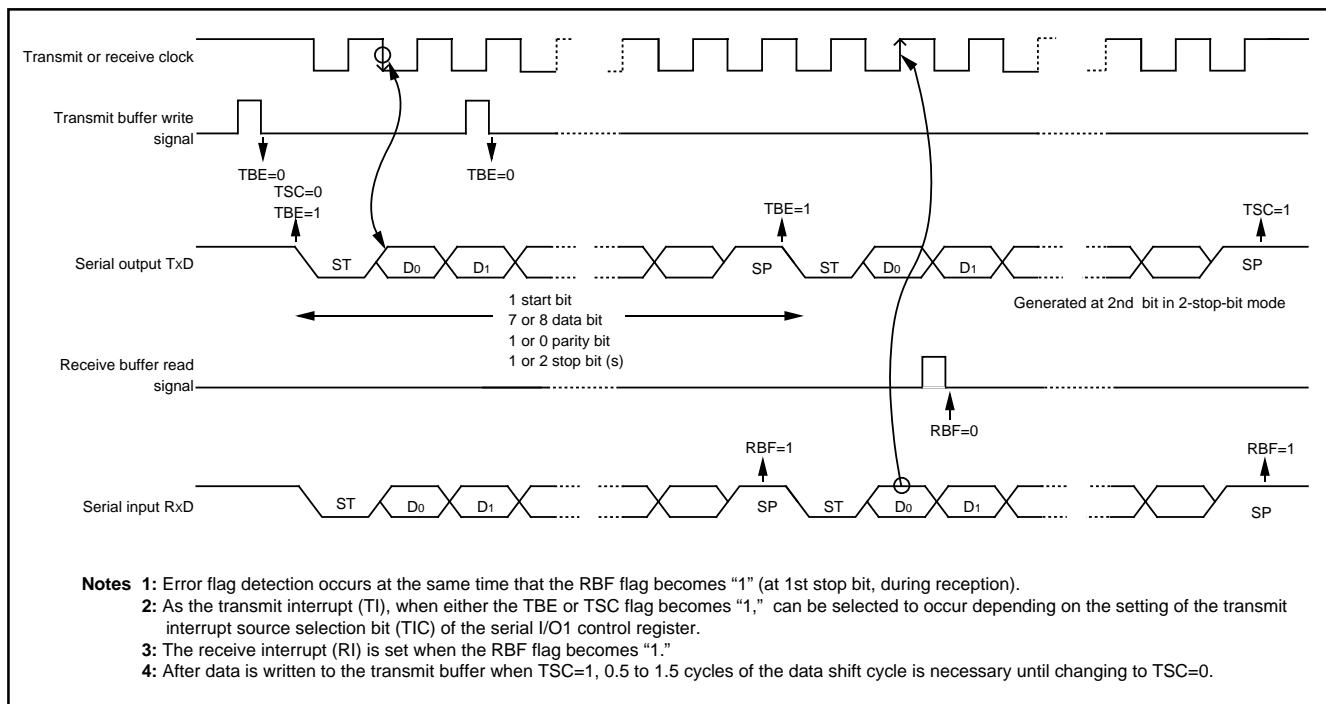

Fig. 21 Operation of UART serial I/O1 function

**[Transmit Buffer Register/Receive Buffer Register (TB/RB)] 001816**

The transmit buffer register and the receive buffer register are located at the same address. The transmit buffer is write-only and the receive buffer is read-only. If a character bit length is 7 bits, the MSB of data stored in the receive buffer is "0".

**[Serial I/O1 Status Register (SIOSTS)] 001916**

The read-only serial I/O1 status register consists of seven flags (bits 0 to 6) which indicate the operating status of the serial I/O1 function and various errors.

Three of the flags (bits 4 to 6) are valid only in UART mode. The receive buffer full flag (bit 1) is cleared to "0" when the receive buffer register is read.

If there is an error, it is detected at the same time that data is transferred from the receive shift register to the receive buffer register, and the receive buffer full flag is set. A write to the serial I/O1 status register clears all the error flags OE, PE, FE, and SE (bit 3 to bit 6, respectively). Writing "0" to the serial I/O1 enable bit SIOE (bit 7 of the serial I/O1 control register) also clears all the status flags, including the error flags.

Bits 0 to 6 of the serial I/O1 status register are initialized to "0" at reset, but if the transmit enable bit (bit 4) of the serial I/O1 control register has been set to "1", the transmit shift completion flag (bit 2) and the transmit buffer empty flag (bit 0) become "1".

**[Serial I/O1 Control Register (SIOCON)] 001A16**

The serial I/O1 control register consists of eight control bits for the serial I/O1 function.

**[UART Control Register (UARTCON)] 001B16**

The UART control register consists of four control bits (bits 0 to 3) which are valid when asynchronous serial I/O is selected and set the data format of an data transfer and one bit (bit 4) which is always valid and sets the output structure of the P25/TxD pin.

**[Baud Rate Generator (BRG)] 001C16**

The baud rate generator determines the baud rate for serial transfer.

The baud rate generator divides the frequency of the count source by  $1/(n + 1)$ , where n is the value written to the baud rate generator.

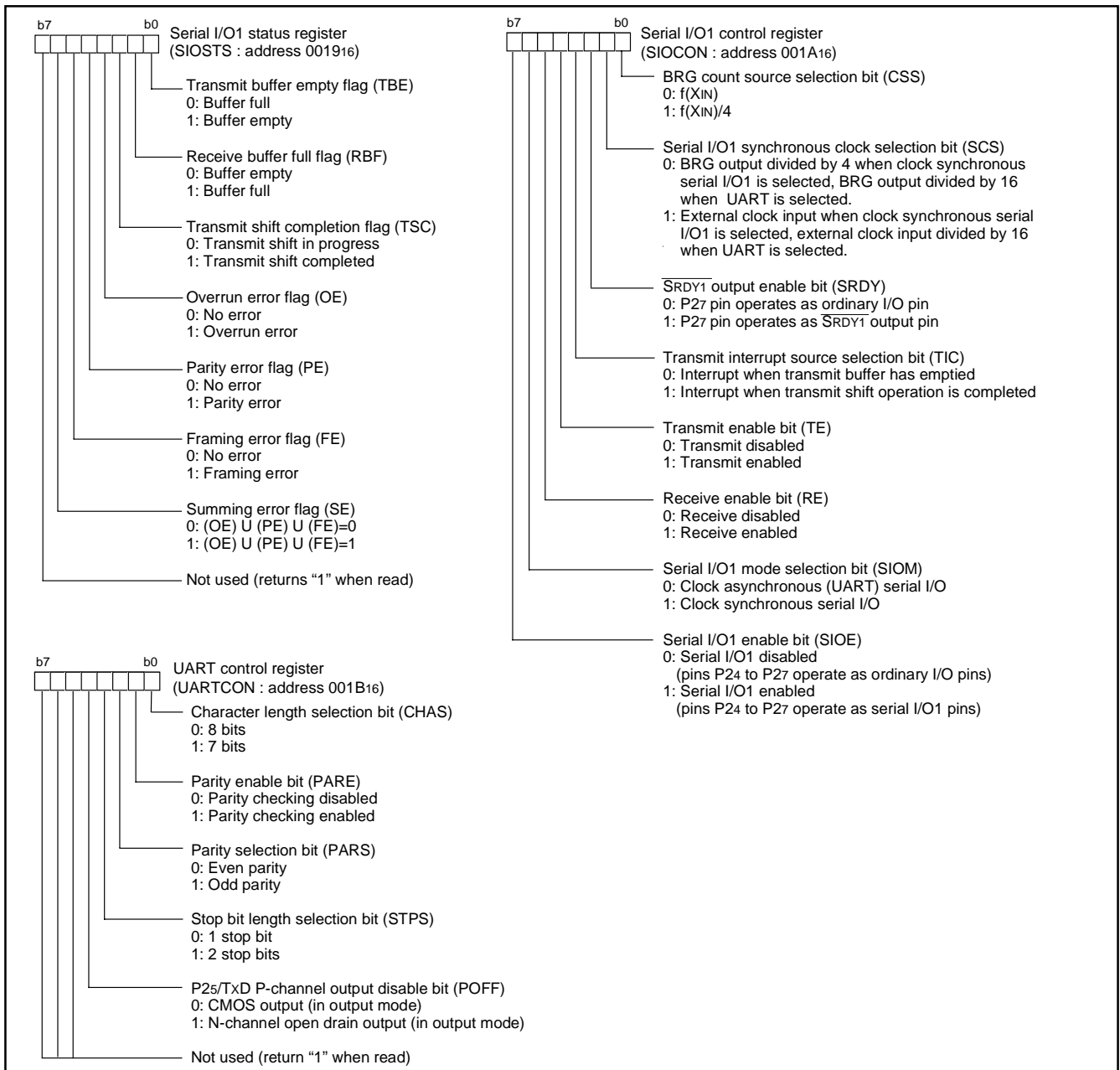

Fig. 22 Structure of serial I/O1 control registers

■Notes on serial I/O1

- When using the serial I/O1, clear the I<sup>2</sup>C-BUS interface enable bit to "0" or the SDA/SCL interrupt pin selection bit to "0".
- When setting the transmit enable bit of serial I/O1 to "1", the serial I/O1 transmit interrupt request bit is automatically set to "1". When not requiring the interrupt occurrence synchronized with the transmission enabled, take the following sequence.
  - Set the serial I/O1 transmit interrupt enable bit to "0" (disabled).
  - Set the transmit enable bit to "1".
  - Set the serial I/O1 transmit interrupt request bit to "0" after 1 or more instructions have been executed.
  - Set the serial I/O1 transmit interrupt enable bit to "1" (enabled).

●SERIAL I/O2

The serial I/O2 can be operated only as the clock synchronous type. As a synchronous clock for serial transfer, either internal clock or external clock can be selected by the serial I/O2 synchronous clock selection bit (b6) of serial I/O2 control register 1.

The internal clock incorporates a dedicated divider and permits selecting 6 types of clock by the internal synchronous clock selection bits (b2, b1, b0) of serial I/O2 control register 1.

Regarding SOUT2 and SCLK2 being output pins, either CMOS output format or N-channel open-drain output format can be selected by the P01/SOUT2, P02/SCLK2 P-channel output disable bit (b7) of serial I/O2 control register 1.

When the internal clock has been selected, a transfer starts by a write signal to the serial I/O2 register (address 001716). After completion of data transfer, the level of the SOUT2 pin goes to high impedance automatically but bit 7 of the serial I/O2 control register 2 is not set to "1" automatically.

When the external clock has been selected, the contents of the serial I/O2 register is continuously sifted while transfer clocks are input. Accordingly, control the clock externally. Note that the SOUT2 pin does not go to high impedance after completion of data transfer.

To cause the SOUT2 pin to go to high impedance in the case where the external clock is selected, set bit 7 of the serial I/O2 control register 2 to "1" when SCLK2 is "H" after completion of data transfer. After the next data transfer is started (the transfer clock falls), bit 7 of the serial I/O2 control register 2 is set to "0" and the SOUT2 pin is put into the active state.

Regardless of the internal clock to external clock, the interrupt request bit is set after the number of bits (1 to 8 bits) selected by the optional transfer bit is transferred. In case of a fractional number of bits less than 8 bits as the last data, the received data to be stored in the serial I/O2 register becomes a fractional number of bits close to MSB if the transfer direction selection bit of serial I/O2 control register 1 is LSB first, or a fractional number of bits close to LSB if the transfer direction selection bit is MSB first. For the remaining bits, the previously received data is shifted.

At transmit operation using the clock synchronous serial I/O, the SCMP2 signal can be output by comparing the state of the transmit pin SOUT2 with the state of the receive pin SIN2 in synchronization with a rise of the transfer clock. If the output level of the SOUT2 pin is equal to the input level to the SIN2 pin, "L" is output from the SCMP2 pin. If not, "H" is output. At this time, an INT2 interrupt request can also be generated. Select a valid edge by bit 2 of the interrupt edge selection register (address 003A16).

[Serial I/O2 Control Registers 1, 2 (SIO2CON1 / SIO2CON2)] 001516, 001616

The serial I/O2 control registers 1 and 2 are containing various selection bits for serial I/O2 control as shown in Figure 23.

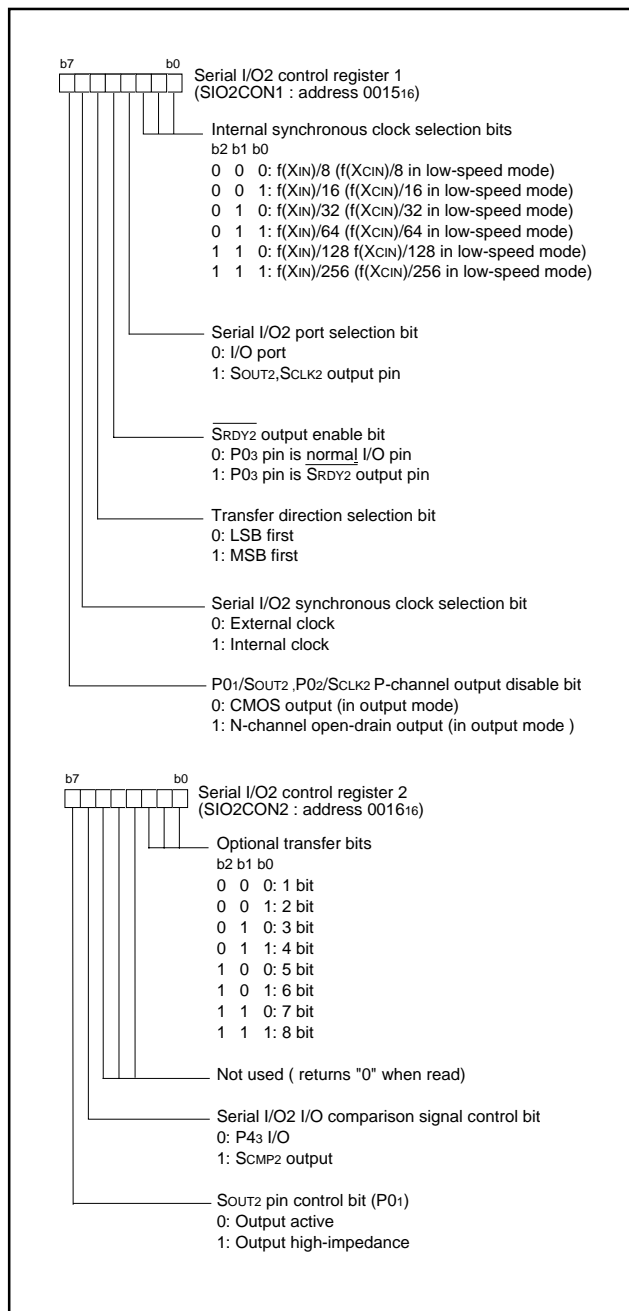

Fig. 23 Structure of Serial I/O2 control registers 1, 2

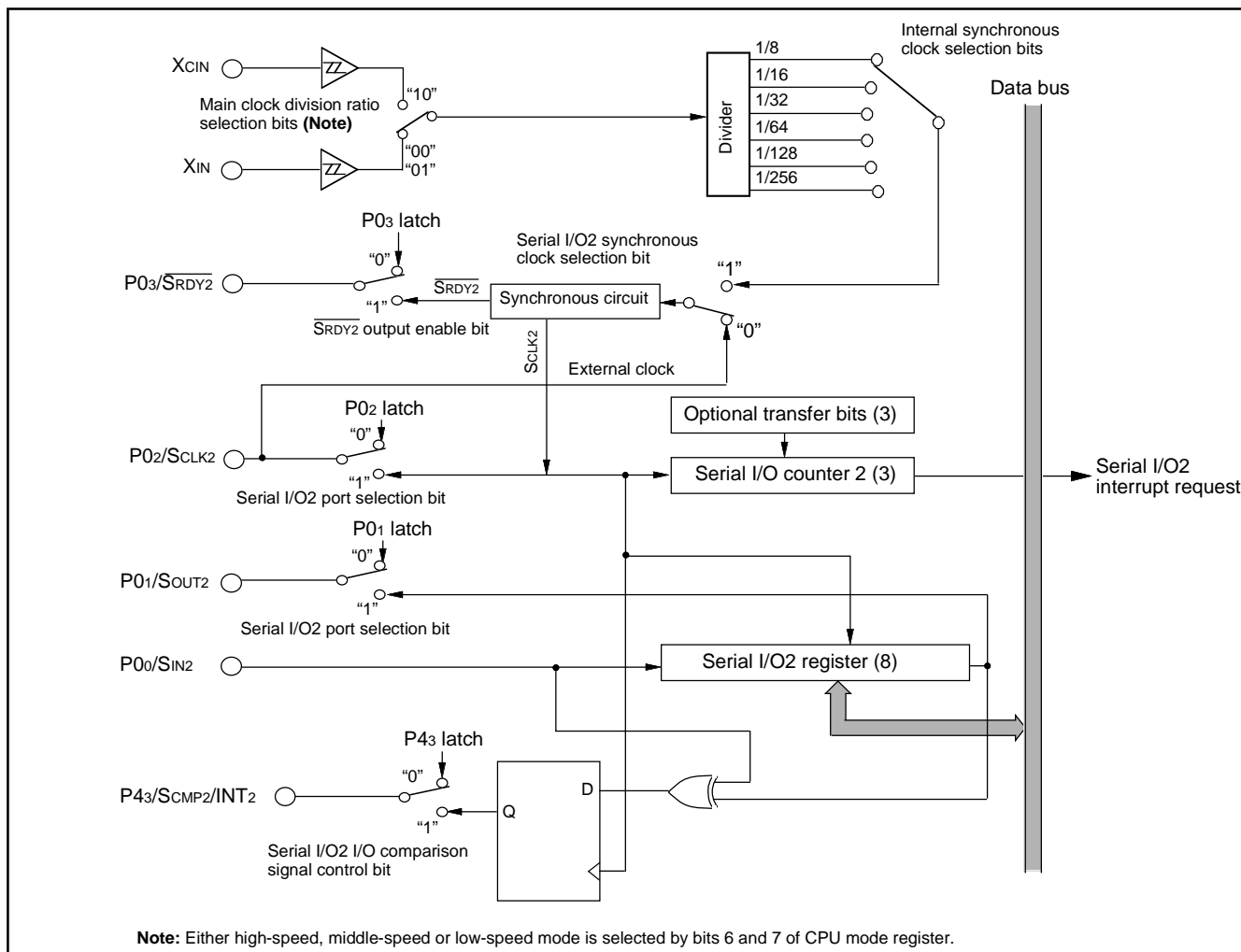

Fig. 24 Block diagram of Serial I/O2

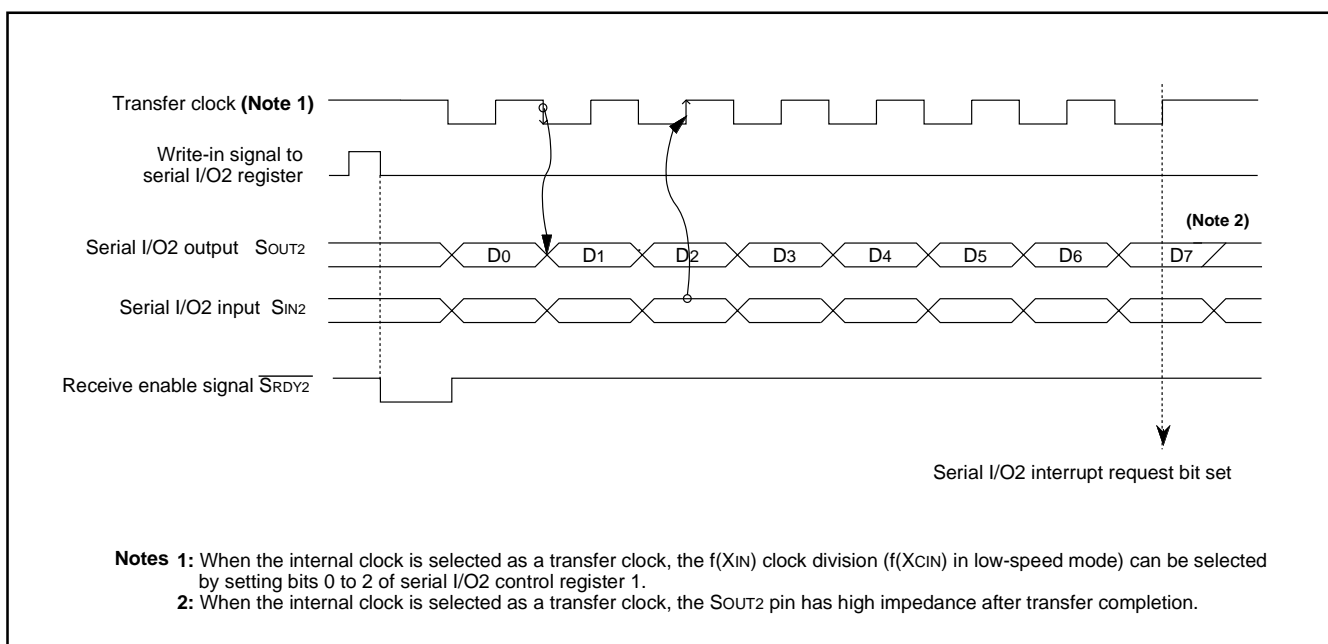

Fig. 25 Timing chart of Serial I/O2

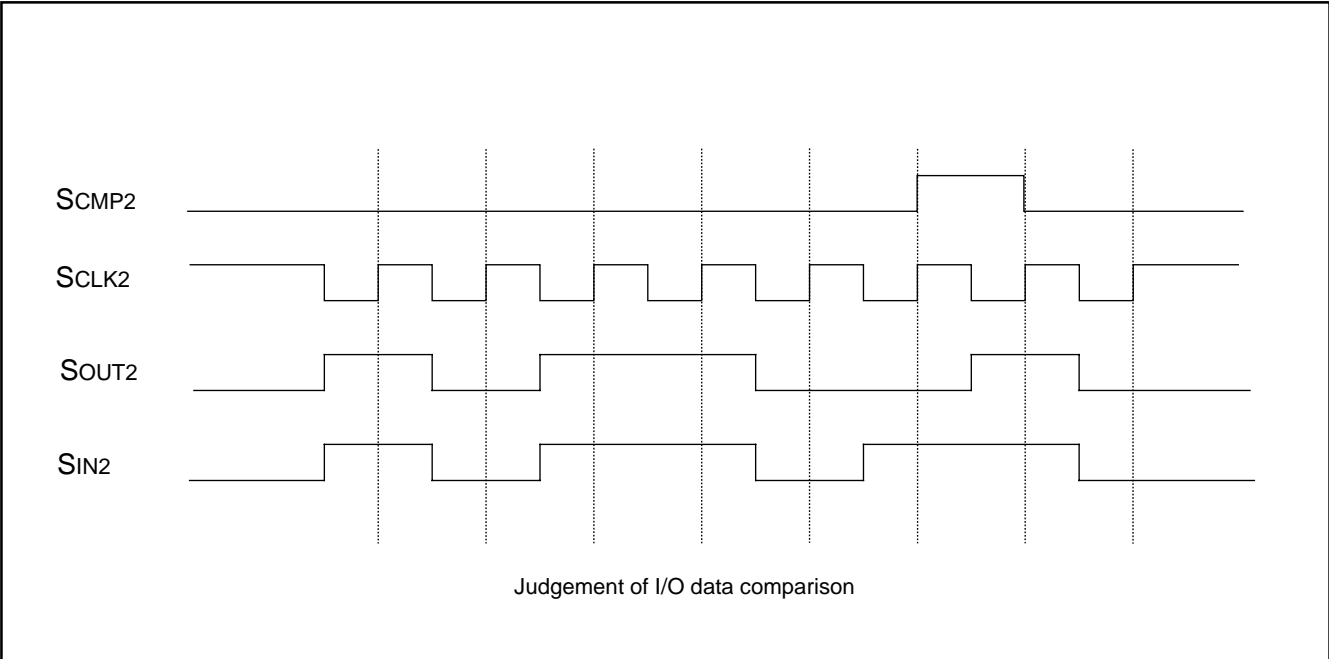

Fig. 26 SCMP2 output operation

**MULTI-MASTER I<sup>2</sup>C-BUS INTERFACE**

The multi-master I<sup>2</sup>C-BUS interface is a serial communications circuit, conforming to the Philips I<sup>2</sup>C-BUS data transfer format. This interface, offering both arbitration lost detection and a synchronous functions, is useful for the multi-master serial communications.

Figure 27 shows a block diagram of the multi-master I<sup>2</sup>C-BUS interface and Table 7 lists the multi-master I<sup>2</sup>C-BUS interface functions.

This multi-master I<sup>2</sup>C-BUS interface consists of the I<sup>2</sup>C address register, the I<sup>2</sup>C data shift register, the I<sup>2</sup>C clock control register, the I<sup>2</sup>C control register, the I<sup>2</sup>C status register, the I<sup>2</sup>C start/stop condition control register and other control circuits.

When using the multi-master I<sup>2</sup>C-BUS interface, set 1 MHz or more to  $\phi$ .

**Note:** Mitsubishi Electric Corporation assumes no responsibility for infringement of any third-party's rights or originating in the use of the connection control function between the I<sup>2</sup>C-BUS interface and the ports SCL1, SCL2, SDA1 and SDA2 with the bit 6 of I<sup>2</sup>C control register (002E16).

**Table 7 Multi-master I<sup>2</sup>C-BUS interface functions**

Item	Function
Format	In conformity with Philips I <sup>2</sup> C-BUS standard: 10-bit addressing format 7-bit addressing format High-speed clock mode Standard clock mode
Communication mode	In conformity with Philips I <sup>2</sup> C-BUS standard: Master transmission Master reception Slave transmission Slave reception
SCL clock frequency	16.1 kHz to 400 kHz (at $\phi = 4$ MHz)

System clock  $\phi = f(XIN)/2$  (high-speed mode)  
 $\phi = f(XIN)/8$  (middle-speed mode)

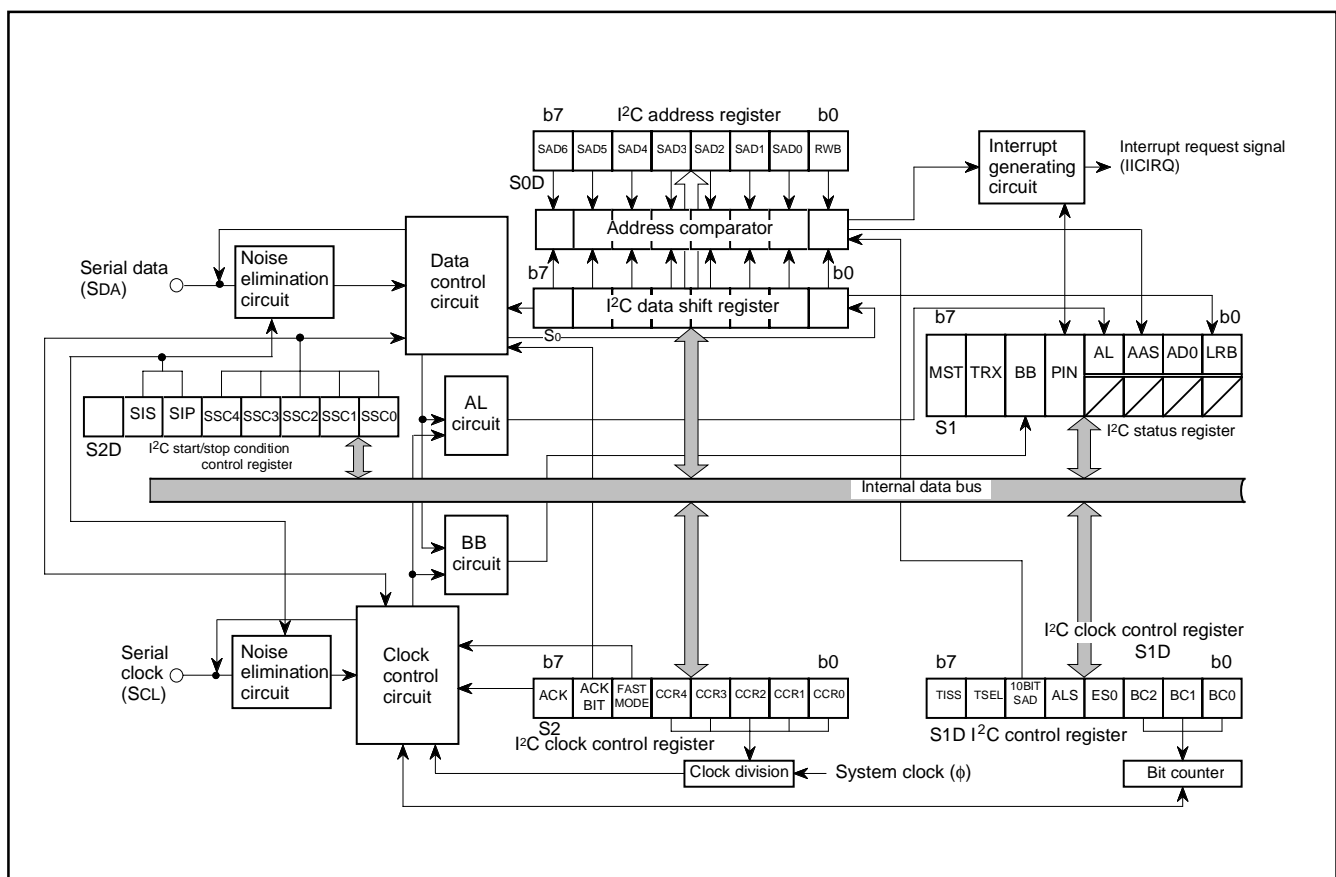

**Fig. 27 Block diagram of multi-master I<sup>2</sup>C-BUS interface**

\* : Purchase of MITSUBISHI ELECTRIC CORPORATIONS I<sup>2</sup>C components conveys a license under the Philips I<sup>2</sup>C Patent Rights to use these components an I<sup>2</sup>C system, provided that the system conforms to the I<sup>2</sup>C Standard Specification as defined by Philips.

**[I<sup>2</sup>C Data Shift Register (S0)] 002B16**

The I<sup>2</sup>C data shift register (S0 : address 002B16) is an 8-bit shift register to store receive data and write transmit data.

When transmit data is written into this register, it is transferred to the outside from bit 7 in synchronization with the SCL clock, and each time one-bit data is output, the data of this register are shifted by one bit to the left. When data is received, it is input to this register from bit 0 in synchronization with the SCL clock, and each time one-bit data is input, the data of this register are shifted by one bit to the left. The minimum 2 machine cycles are required from the rising of the SCL clock until input to this register.

The I<sup>2</sup>C data shift register is in a write enable status only when the I<sup>2</sup>C-BUS interface enable bit (ES0 bit : bit 3 of address 002E16) of the I<sup>2</sup>C control register is "1". The bit counter is reset by a write instruction to the I<sup>2</sup>C data shift register. When both the ES0 bit and the MST bit of the I<sup>2</sup>C status register (address 002D16) are "1," the SCL is output by a write instruction to the I<sup>2</sup>C data shift register. Reading data from the I<sup>2</sup>C data shift register is always enabled regardless of the ES0 bit value.

**[I<sup>2</sup>C Address Register (S0D)] 002C16**

The I<sup>2</sup>C address register (address 002C16) consists of a 7-bit slave address and a read/write bit. In the addressing mode, the slave address written in this register is compared with the address data to be received immediately after the START condition is detected.

**•Bit 0: Read/write bit (RWB)**

This is not used in the 7-bit addressing mode. In the 10-bit addressing mode, the first address data to be received is compared with the contents (SAD6 to SAD0 + RWB) of the I<sup>2</sup>C address register.

The RWB bit is cleared to "0" automatically when the stop condition is detected.

**•Bits 1 to 7: Slave address (SAD0–SAD6)**

These bits store slave addresses. Regardless of the 7-bit addressing mode and the 10-bit addressing mode, the address data transmitted from the master is compared with the contents of these bits.

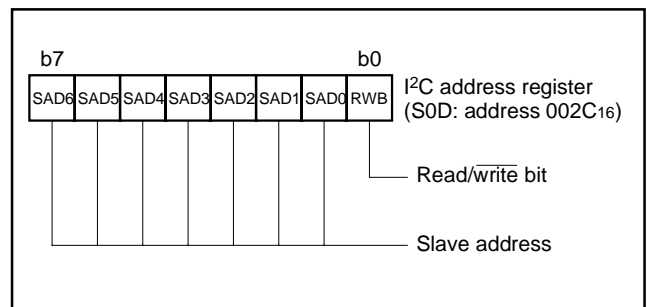

Fig. 28 Structure of I<sup>2</sup>C address register

**[I<sup>2</sup>C Clock Control Register (S2)] 002F16**

The I<sup>2</sup>C clock control register (address 002F16) is used to set ACK control, SCL mode and SCL frequency.

**•Bits 0 to 4: SCL frequency control bits (CCR0–CCR4)**

These bits control the SCL frequency. Refer to Table 8.

**•Bit 5: SCL mode specification bit (FAST MODE)**

This bit specifies the SCL mode. When this bit is set to “0,” the standard clock mode is selected. When the bit is set to “1,” the high-speed clock mode is selected.

When connecting the bus of the high-speed mode I<sup>2</sup>C bus standard (maximum 400 kbits/s), use 8 MHz or more oscillation frequency f(XIN) and 2 division clock.

**•Bit 6: ACK bit (ACK BIT)**

This bit sets the SDA status when an ACK clock\* is generated. When this bit is set to “0,” the ACK return mode is selected and SDA goes to “L” at the occurrence of an ACK clock. When the bit is set to “1,” the ACK non-return mode is selected. The SDA is held in the “H” status at the occurrence of an ACK clock.

However, when the slave address agree with the address data in the reception of address data at ACK BIT = “0,” the SDA is automatically made “L” (ACK is returned). If there is a disagreement between the slave address and the address data, the SDA is automatically made “H” (ACK is not returned).

\*ACK clock: Clock for acknowledgment

**•Bit 7: ACK clock bit (ACK)**

This bit specifies the mode of acknowledgment which is an acknowledgment response of data transfer. When this bit is set to “0,” the no ACK clock mode is selected. In this case, no ACK clock occurs after data transmission. When the bit is set to “1,” the ACK clock mode is selected and the master generates an ACK clock each completion of each 1-byte data transfer. The device for transmitting address data and control data releases the SDA at the occurrence of an ACK clock (makes SDA “H”) and receives the ACK bit generated by the data receiving device.

**Note:** Do not write data into the I<sup>2</sup>C clock control register during transfer. If data is written during transfer, the I<sup>2</sup>C clock generator is reset, so that data cannot be transferred normally.

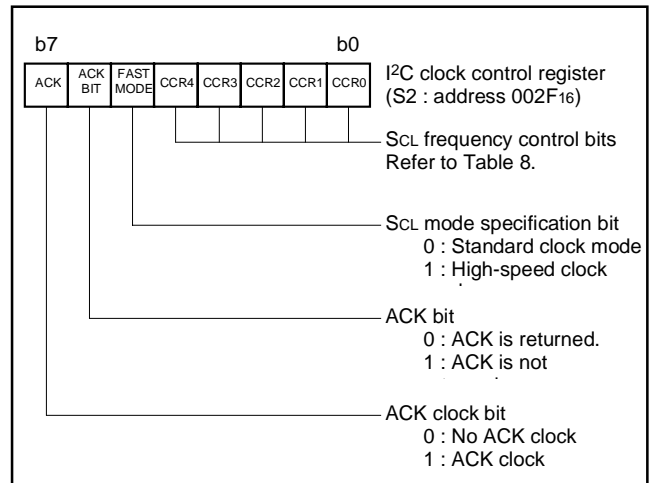

**Fig. 29** Structure of I<sup>2</sup>C clock control register

**Table 8** Set values of I<sup>2</sup>C clock control register and SCL frequency

Setting value of CCR4–CCR0					SCL frequency (Note 1) (at $\phi = 4$ MHz, unit : kHz)	
CCR4	CCR3	CCR2	CCR1	CCR0	Standard clock mode	High-speed clock mode
0	0	0	0	0	Setting disabled	Setting disabled
0	0	0	0	1	Setting disabled	Setting disabled
0	0	0	1	0	Setting disabled	Setting disabled
0	0	0	1	1	– (Note 2)	333
0	0	1	0	0	– (Note 2)	250
0	0	1	0	1	100	400 (Note 3)
0	0	1	1	0	83.3	166
:	:	:	:	:	500/CCR value (Note 3)	1000/CCR value (Note 3)
1	1	1	0	1	17.2	34.5
1	1	1	1	0	16.6	33.3
1	1	1	1	1	16.1	32.3

**Notes 1:** Duty of SCL clock output is 50 %. The duty becomes 35 to 45 % only when the high-speed clock mode is selected and CCR value = 5 (400 kHz, at  $\phi = 4$  MHz). “H” duration of the clock fluctuates from –4 to +2 machine cycles in the standard clock mode, and fluctuates from –2 to +2 machine cycles in the high-speed clock mode. In the case of negative fluctuation, the frequency does not increase because “L” duration is extended instead of “H” duration reduction.

These are value when SCL clock synchronization by the synchronous function is not performed. CCR value is the decimal notation value of the SCL frequency control bits CCR4 to CCR0.

**2:** Each value of SCL frequency exceeds the limit at  $\phi = 4$  MHz or more. When using these setting value, use  $\phi$  of 4 MHz or less.

**3:** The data formula of SCL frequency is described below:

$\phi / (8 \times \text{CCR value})$  Standard clock mode

$\phi / (4 \times \text{CCR value})$  High-speed clock mode (CCR value  $\neq 5$ )

$\phi / (2 \times \text{CCR value})$  High-speed clock mode (CCR value = 5)

Do not set 0 to 2 as CCR value regardless of  $\phi$  frequency.

Set 100 kHz (max.) in the standard clock mode and 400 kHz (max.) in the high-speed clock mode to the SCL frequency by setting the SCL frequency control bits CCR4 to CCR0.



**[I<sup>2</sup>C Control Register (S1D)] 002E16**

The I<sup>2</sup>C control register (address 002E16) controls data communication format.

**•Bits 0 to 2: Bit counter (BC0–BC2)**

These bits decide the number of bits for the next 1-byte data to be transmitted. The I<sup>2</sup>C interrupt request signal occurs immediately after the number of count specified with these bits (ACK clock is added to the number of count when ACK clock is selected by ACK clock bit (bit 7 of address 002F16)) have been transferred, and BC0 to BC2 are returned to "0002".

Also when a START condition is received, these bits become "0002" and the address data is always transmitted and received in 8 bits.

**•Bit 3: I<sup>2</sup>C interface enable bit (ES0)**

This bit enables to use the multi-master I<sup>2</sup>C-BUS interface. When this bit is set to "0," the use disable status is provided, so that the SDA and the SCL become high-impedance. When the bit is set to "1," use of the interface is enabled.

When ES0 = "0," the following is performed.

- PIN = "1," BB = "0" and AL = "0" are set (which are bits of the I<sup>2</sup>C status register at address 002D16).
- Writing data to the I<sup>2</sup>C data shift register (address 002B16) is disabled.

**•Bit 4: Data format selection bit (ALS)**

This bit decides whether or not to recognize slave addresses. When this bit is set to "0," the addressing format is selected, so that address data is recognized. When a match is found between a slave address and address data as a result of comparison or when a general call (refer to "I<sup>2</sup>C Status Register," bit 1) is received, transfer processing can be performed. When this bit is set to "1," the free data format is selected, so that slave addresses are not recognized.

**•Bit 5: Addressing format selection bit (10BIT SAD)**

This bit selects a slave address specification format. When this bit is set to "0," the 7-bit addressing format is selected. In this case, only the high-order 7 bits (slave address) of the I<sup>2</sup>C address register (address 002C16) are compared with address data. When this bit is set to "1," the 10-bit addressing format is selected, and all the bits of the I<sup>2</sup>C address register are compared with address data.

**•Bit 6: SDA/SCL pin selection bit**

This bit selects the input/output pins of SCL and SDA of the multi-master I<sup>2</sup>C-BUS interface.

**•Bit 7: I<sup>2</sup>C-BUS interface pin input level selection bit**

This bit selects the input level of the SCL and SDA pins of the multi-master I<sup>2</sup>C-BUS interface.

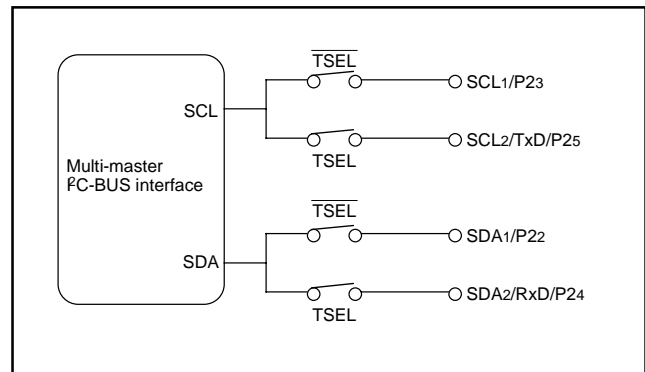

Fig. 30 SDA/SCL pin selection bit

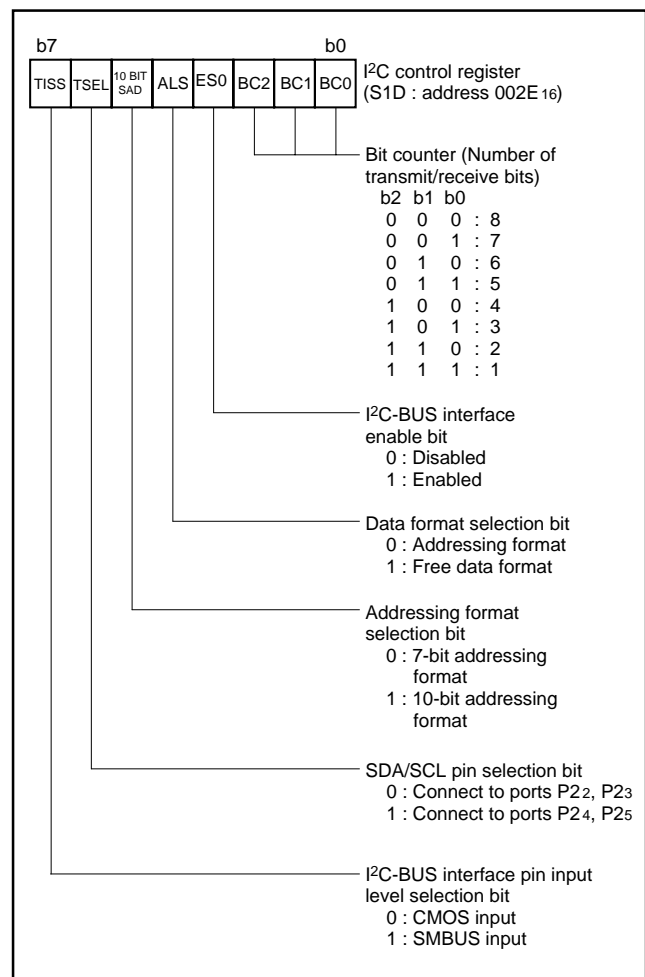

Fig. 31 Structure of I<sup>2</sup>C control register

**[I<sup>2</sup>C Status Register (S1)] 002D16**

The I<sup>2</sup>C status register (address 002D16) controls the I<sup>2</sup>C-BUS interface status. The low-order 4 bits are read-only bits and the high-order 4 bits can be read out and written to.

Set "00002" to the low-order 4 bits, because these bits become the reserved bits at writing.

**•Bit 0: Last receive bit (LRB)**

This bit stores the last bit value of received data and can also be used for ACK receive confirmation. If ACK is returned when an ACK clock occurs, the LRB bit is set to "0." If ACK is not returned, this bit is set to "1." Except in the ACK mode, the last bit value of received data is input. The state of this bit is changed from "1" to "0" by executing a write instruction to the I<sup>2</sup>C data shift register (address 002B16).

**•Bit 1: General call detecting flag (AD0)**

When the ALS bit is "0", this bit is set to "1" when a general call\* whose address data is all "0" is received in the slave mode. By a general call of the master device, every slave device receives control data after the general call. The AD0 bit is set to "0" by detecting the STOP condition or START condition, or reset.

\*General call: The master transmits the general call address "0016" to all slaves.

**•Bit 2: Slave address comparison flag (AAS)**

This flag indicates a comparison result of address data when the ALS bit is "0".

- ① In the slave receive mode, when the 7-bit addressing format is selected, this bit is set to "1" in one of the following conditions:
  - The address data immediately after occurrence of a START condition agrees with the slave address stored in the high-order 7 bits of the I<sup>2</sup>C address register (address 002C16).
  - A general call is received.
- ② In the slave receive mode, when the 10-bit addressing format is selected, this bit is set to "1" with the following condition:
  - When the address data is compared with the I<sup>2</sup>C address register (8 bits consisting of slave address and RWB bit), the first bytes agree.
- ③ This bit is set to "0" by executing a write instruction to the I<sup>2</sup>C data shift register (address 002B16) when ES0 is set to "1" or reset.

**•Bit 3: Arbitration lost\* detecting flag (AL)**

In the master transmission mode, when the SDA is made "L" by any other device, arbitration is judged to have been lost, so that this bit is set to "1." At the same time, the TRX bit is set to "0," so that immediately after transmission of the byte whose arbitration was lost is completed, the MST bit is set to "0." The arbitration lost can be detected only in the master transmission mode. When arbitration is lost during slave address transmission, the TRX bit is set to "0" and the reception mode is set. Consequently, it becomes possible to detect the agreement of its own slave address and address data transmitted by another master device.

\*Arbitration lost: The status in which communication as a master is disabled.

**•Bit 4: SCL pin low hold bit (PIN)**

This bit generates an interrupt request signal. Each time 1-byte data is transmitted, the PIN bit changes from "1" to "0." At the same time, an interrupt request signal occurs to the CPU. The PIN bit is set to "0" in synchronization with a falling of the last clock (including the ACK clock) of an internal clock and an interrupt request signal occurs in synchronization with a falling of the PIN bit. When the PIN bit is "0," the SCL is kept in the "0" state and clock generation is disabled. Figure 33 shows an interrupt request signal generating timing chart.

The PIN bit is set to "1" in one of the following conditions:

- Executing a write instruction to the I<sup>2</sup>C data shift register (address 002B16). (This is the only condition which the prohibition of the internal clock is released and data can be communicated except for the start condition detection.)
- When the ES0 bit is "0"
- At reset
- When writing "1" to the PIN bit by software

The conditions in which the PIN bit is set to "0" are shown below:

- Immediately after completion of 1-byte data transmission (including when arbitration lost is detected)
- Immediately after completion of 1-byte data reception
- In the slave reception mode, with ALS = "0" and immediately after completion of slave address agreement or general call address reception
- In the slave reception mode, with ALS = "1" and immediately after completion of address data reception

**•Bit 5: Bus busy flag (BB)**

This bit indicates the status of use of the bus system. When this bit is set to "0," this bus system is not busy and a START condition can be generated. The BB flag is set/reset by the SCL, SDA pins input signal regardless of master/slave. This flag is set to "1" by detecting the start condition, and is set to "0" by detecting the stop condition. The condition of these detecting is set by the start/stop condition setting bits (SSC4–SSC0) of the I<sup>2</sup>C start/stop condition control register (address 003016). When the ES0 bit of the I<sup>2</sup>C control register (address 002E16) is "0" or reset, the BB flag is set to "0."

For the writing function to the BB flag, refer to the sections "START Condition Generating Method" and "STOP Condition Generating Method" described later.

**•Bit 6: Communication mode specification bit (transfer direction specification bit: TRX)**

This bit decides a direction of transfer for data communication. When this bit is "0," the reception mode is selected and the data of a transmitting device is received. When the bit is "1," the transmission mode is selected and address data and control data are output onto the SDA in synchronization with the clock generated on the SCL.

This bit is set/reset by software and hardware. About set/reset by hardware is described below. This bit is set to "1" by hardware when all the following conditions are satisfied:

- When ALS is "0"
- In the slave reception mode or the slave transmission mode
- When the R/W bit reception is "1"

This bit is set to "0" in one of the following conditions:

- When arbitration lost is detected.
- When a STOP condition is detected.
- When writing "1" to this bit by software is invalid by the START condition duplication preventing function (**Note**).
- With MST = "0" and when a START condition is detected.
- With MST = "0" and when ACK non-return is detected.

• At reset

**•Bit 7: Communication mode specification bit (master/slave specification bit: MST)**

This bit is used for master/slave specification for data communication. When this bit is "0," the slave is specified, so that a START condition and a STOP condition generated by the master are received, and data communication is performed in synchronization with the clock generated by the master. When this bit is "1," the master is specified and a START condition and a STOP condition are generated. Additionally, the clocks required for data communication are generated on the SCL.

This bit is set to "0" in one of the following conditions.

- Immediately after completion of 1-byte data transfer when arbitration lost is detected
- When a STOP condition is detected.
- Writing "1" to this bit by software is invalid by the START condition duplication preventing function (**Note**).
- At reset

**Note:** START condition duplication preventing function

The MST, TRX, and BB bits is set to "1" at the same time after confirming that the BB flag is "0" in the procedure of a START condition occurrence. However, when a START condition by another master device occurs and the BB flag is set to "1" immediately after the contents of the BB flag is confirmed, the START condition duplication preventing function makes the writing to the MST and TRX bits invalid. The duplication preventing function becomes valid from the rising of the BB flag to reception completion of slave address.

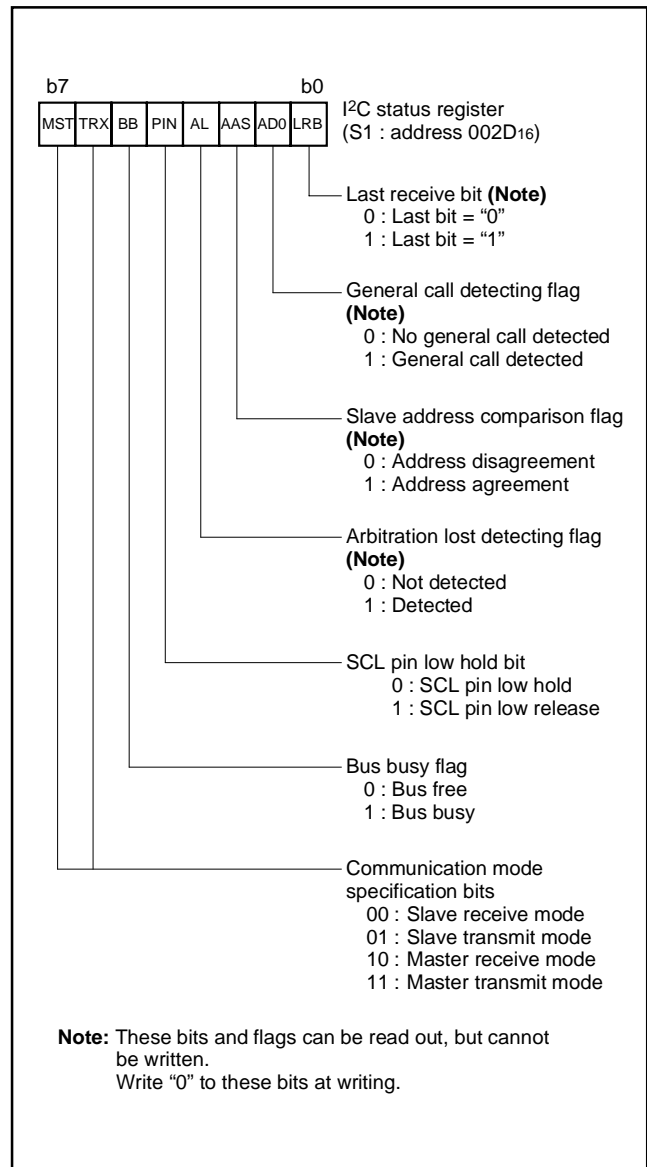

Fig. 32 Structure of I<sup>2</sup>C status register

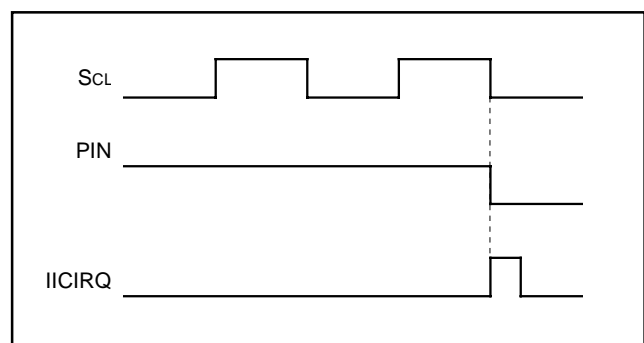

Fig. 33 Interrupt request signal generating timing

**START Condition Generating Method**

When writing "1" to the MST, TRX, and BB bits of the I<sup>2</sup>C status register (address 002D16) at the same time after writing the slave address to the I<sup>2</sup>C data shift register (address 002B16) with the condition in which the ES0 bit of the I<sup>2</sup>C control register (address 002E16) and the BB flag are "0", a START condition occurs. After that, the bit counter becomes "0002" and an SCL for 1 byte is output. The START condition generating timing is different in the standard clock mode and the high-speed clock mode. Refer to Figure 34, the START condition generating timing diagram, and Table 9, the START condition generating timing table.

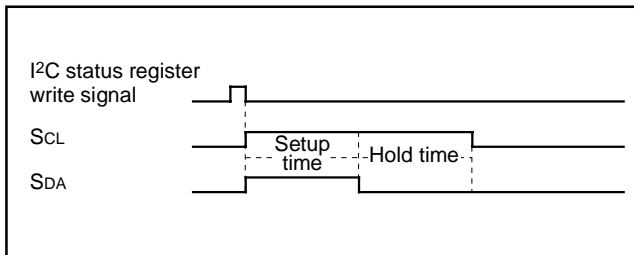

Fig. 34 START condition generating timing diagram

Table 9 START condition generating timing table

Item	Standard clock mode	High-speed clock mode
Setup time	5.0 μs (20 cycles)	2.5 μs (10 cycles)
Hold time	5.0 μs (20 cycles)	2.5 μs (10 cycles)

Note: Absolute time at φ = 4 MHz. The value in parentheses denotes the number of φ cycles.

**STOP Condition Generating Method**

When the ES0 bit of the I<sup>2</sup>C control register (address 002E16) is "1," write "1" to the MST and TRX bits, and write "0" to the BB bit of the I<sup>2</sup>C status register (address 002D16) simultaneously. Then a STOP condition occurs. The STOP condition generating timing is different in the standard clock mode and the high-speed clock mode. Refer to Figure 35, the STOP condition generating timing diagram, and Table 10, the STOP condition generating timing table.

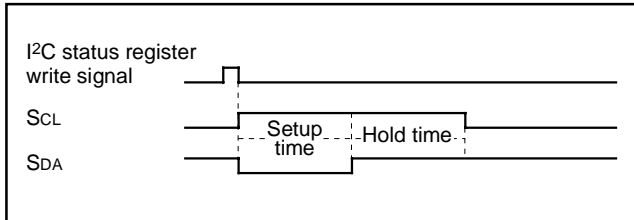

Fig. 35 STOP condition generating timing diagram

Table 10 STOP condition generating timing table

Item	Standard clock mode	High-speed clock mode
Setup time	5.0 μs (20 cycles)	3.0 μs (12 cycles)
Hold time	4.5 μs (18 cycles)	2.5 μs (10 cycles)

Note: Absolute time at φ = 4 MHz. The value in parentheses denotes the number of φ cycles.

**START/STOP Condition Detecting Operation**

The START/STOP condition detection operations are shown in Figures 36, 37, and Table 11. The START/STOP condition is set by the START/STOP condition set bit.

The START/STOP condition can be detected only when the input signal of the SCL and SDA pins satisfy three conditions: SCL release time, setup time, and hold time (see Table 11).

The BB flag is set to "1" by detecting the START condition and is reset to "0" by detecting the STOP condition.

The BB flag set/reset timing is different in the standard clock mode and the high-speed clock mode. Refer to Table 11, the BB flag set/reset time.

Note: When a STOP condition is detected in the slave mode (MST = 0), an interrupt request signal "IICIRQ" occurs to the CPU.

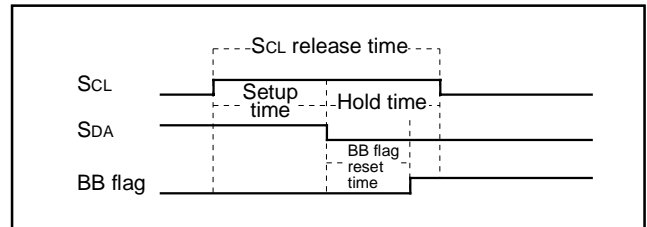

Fig. 36 START condition detecting timing diagram

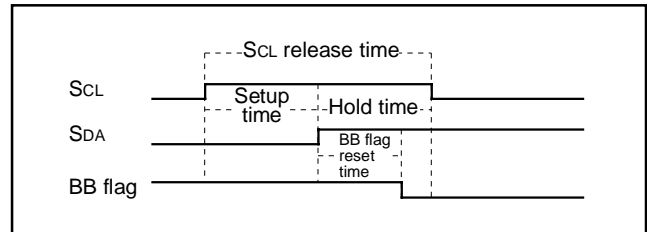

Fig. 37 STOP condition detecting timing diagram

Table 11 START condition/STOP condition detecting conditions

	Standard clock mode	High-speed clock mode
SCL release time	SSC value + 1 cycle (6.25 μs)	4 cycles (1.0 μs)
Setup time	$\frac{SSC\ value + 1}{2}$ cycle < 4.0 μs (3.125 μs)	2 cycles (1.0 μs)
Hold time	$\frac{SSC\ value + 1}{2}$ cycle < 4.0 μs (3.125 μs)	2 cycles (0.5 μs)
BB flag set/reset time	$\frac{SSC\ value - 1}{2} + 2$ cycles (3.375 μs)	3.5 cycles (0.875 μs)

Note: Unit : Cycle number of system clock φ  
 SSC value is the decimal notation value of the START/STOP condition set bits SSC4 to SSC0. Do not set "0" or an odd number to SSC value. The value in parentheses is an example when the I<sup>2</sup>C START/STOP condition control register is set to "1816" at φ = 4 MHz.

## [I<sup>2</sup>C START/STOP Condition Control Register (S2D)] 003016

The I<sup>2</sup>C START/STOP condition control register (address 003016) controls START/STOP condition detection.

### •Bits 0 to 4: START/STOP condition set bit (SSC4–SSC0)

SCL release time, setup time, and hold time change the detection condition by value of the main clock divide ratio selection bit and the oscillation frequency  $f(XIN)$  because these time are measured by the internal system clock. Accordingly, set the proper value to the START/STOP condition set bits (SSC4 to SSC0) in considered of the system clock frequency. Refer to Table 11.

Do not set "000002" or an odd number to the START/STOP condition set bit (SSC4 to SSC0).

Refer to Table 12, the recommended set value to START/STOP condition set bits (SSC4–SSC0) for each oscillation frequency.

### •Bit 5: SCL/SDA interrupt pin polarity selection bit (SIP)

An interrupt can occur when detecting the falling or rising edge of the SCL or SDA pin. This bit selects the polarity of the SCL or SDA pin interrupt pin.

### •Bit 6: SCL/SDA interrupt pin selection bit (SIS)

This bit selects the pin of which interrupt becomes valid between the SCL pin and the SDA pin.

**Note:** When changing the setting of the SCL/SDA interrupt pin polarity selection bit, the SCL/SDA interrupt pin selection bit, or the I<sup>2</sup>C-BUS interface enable bit ES0, the SCL/SDA interrupt request bit may be set. When selecting the SCL/SDA interrupt source, disable the interrupt before the SCL/SDA interrupt pin polarity selection bit, the SCL/SDA interrupt pin selection bit, or the I<sup>2</sup>C-BUS interface enable bit ES0 is set. Reset the request bit to "0" after setting these bits, and enable the interrupt.

## Address Data Communication

There are two address data communication formats, namely, 7-bit addressing format and 10-bit addressing format. The respective address communication formats are described below.

### ① 7-bit addressing format

To adapt the 7-bit addressing format, set the 10BIT SAD bit of the I<sup>2</sup>C control register (address 002E16) to "0." The first 7-bit address data transmitted from the master is compared with the high-order 7-bit slave address stored in the I<sup>2</sup>C address register (address 002C16). At the time of this comparison, address comparison of the RWB bit of the I<sup>2</sup>C address register (address 002C16) is not performed. For the data transmission format when the 7-bit addressing format is selected, refer to Figure 39, (1) and (2).

### ② 10-bit addressing format

To adapt the 10-bit addressing format, set the 10BIT SAD bit of the I<sup>2</sup>C control register (address 002E16) to "1." An address comparison is performed between the first-byte address data transmitted from the master and the 8-bit slave address stored in the I<sup>2</sup>C address register (address 002C16). At the time of this comparison, an address comparison between the RWB bit of the I<sup>2</sup>C address register (address 002C16) and the R/W bit which is the last bit of the address data transmitted from the master is made. In the 10-bit addressing mode, the RWB bit which is the last bit of the address data not only specifies the direction of communication for control data, but also is processed as an address data bit.

When the first-byte address data agree with the slave address, the AAS bit of the I<sup>2</sup>C status register (address 002D16) is set to "1." After the second-byte address data is stored into the I<sup>2</sup>C data shift register (address 002B16), perform an address comparison between the second-byte data and the slave address by software. When the address data of the 2 bytes agree with the slave address, set the RWB bit of the I<sup>2</sup>C address register (address 002C16) to "1" by software. This processing can make the 7-bit slave address and R/W data agree, which are received after a RESTART condition is detected, with the value of the I<sup>2</sup>C address register (address 002C16). For the data transmission format when the 10-bit addressing format is selected, refer to Figure 39, (3) and (4).

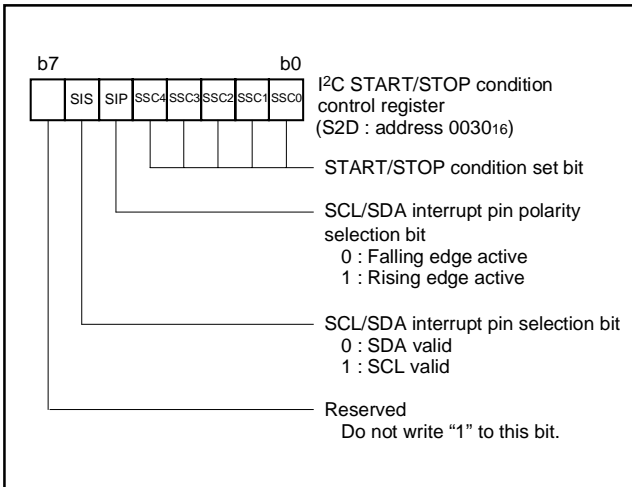

Fig. 38 Structure of I<sup>2</sup>C START/STOP condition control register

Table 12 Recommended set value to START/STOP condition set bits (SSC4–SSC0) for each oscillation frequency

Oscillation frequency f(X <sub>IN</sub> ) (MHz)	Main clock divide ratio	System clock $\phi$ (MHz)	START/STOP condition control register	SCL release time ( $\mu$ s)	Setup time ( $\mu$ s)	Hold time ( $\mu$ s)
8	2	4	XXX11010	6.75 $\mu$ s (27 cycles)	3.375 $\mu$ s (13.5 cycles)	3.375 $\mu$ s (13.5 cycles)
			XXX11000	6.25 $\mu$ s (25 cycles)	3.125 $\mu$ s (12.5 cycles)	3.125 $\mu$ s (12.5 cycles)
8	8	1	XXX00100	5.0 $\mu$ s (5 cycles)	2.5 $\mu$ s (2.5 cycles)	2.5 $\mu$ s (2.5 cycles)
4	2	2	XXX01100	6.5 $\mu$ s (13 cycles)	3.25 $\mu$ s (6.5 cycles)	3.25 $\mu$ s (6.5 cycles)
			XXX01010	5.5 $\mu$ s (11 cycles)	2.75 $\mu$ s (5.5 cycles)	2.75 $\mu$ s (5.5 cycles)
2	2	1	XXX00100	5.0 $\mu$ s (5 cycles)	2.5 $\mu$ s (2.5 cycles)	2.5 $\mu$ s (2.5 cycles)

Note: Do not set an odd number to the START/STOP condition set bit (SSC4 to SSC0).

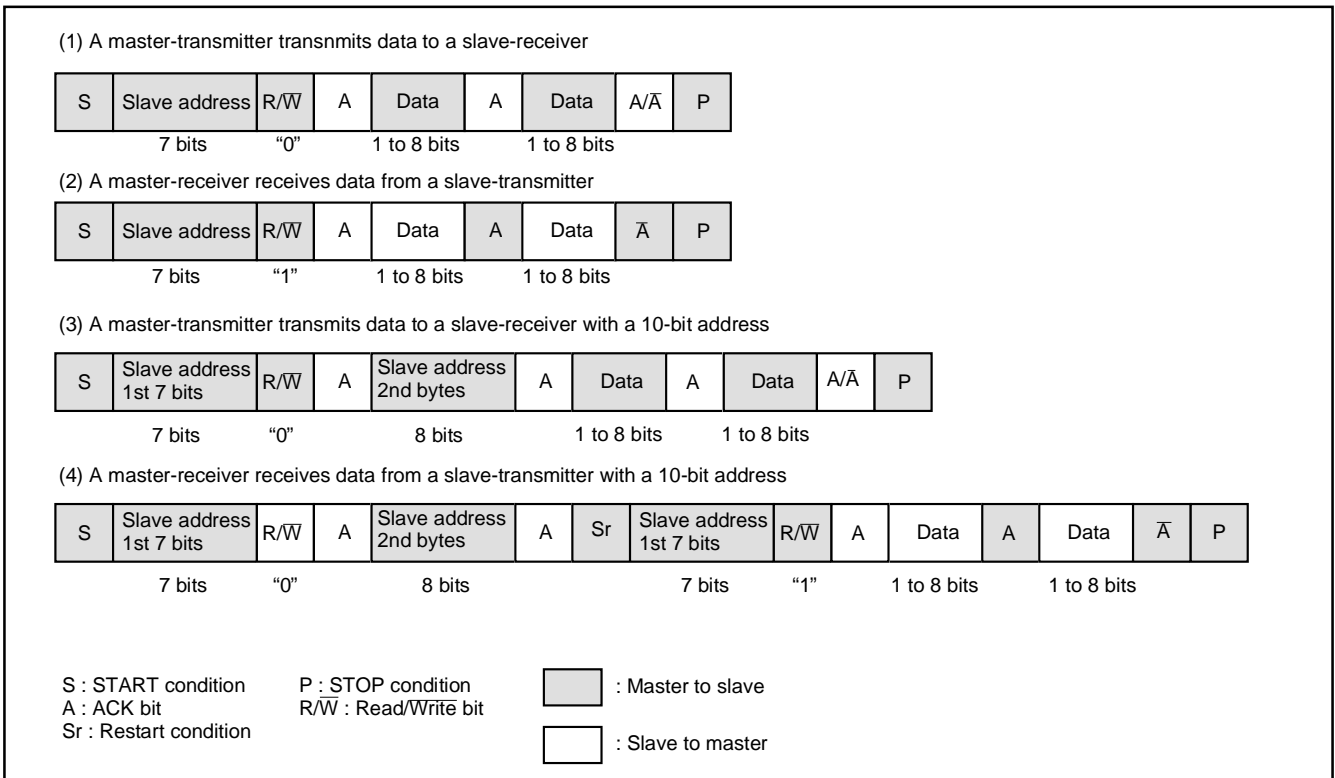

Fig. 39 Address data communication format

### Example of Master Transmission

An example of master transmission in the standard clock mode, at the SCL frequency of 100 kHz and in the ACK return mode is shown below.

- ① Set a slave address in the high-order 7 bits of the I<sup>2</sup>C address register (address 002C<sub>16</sub>) and "0" into the RWB bit.
- ② Set the ACK return mode and SCL = 100 kHz by setting "85<sub>16</sub>" in the I<sup>2</sup>C clock control register (address 002F<sub>16</sub>).
- ③ Set "00<sub>16</sub>" in the I<sup>2</sup>C status register (address 002D<sub>16</sub>) so that transmission/reception mode can become initializing condition.
- ④ Set a communication enable status by setting "08<sub>16</sub>" in the I<sup>2</sup>C control register (address 002E<sub>16</sub>).
- ⑤ Confirm the bus free condition by the BB flag of the I<sup>2</sup>C status register (address 002D<sub>16</sub>).
- ⑥ Set the address data of the destination of transmission in the high-order 7 bits of the I<sup>2</sup>C data shift register (address 002B<sub>16</sub>) and set "0" in the least significant bit.
- ⑦ Set "F0<sub>16</sub>" in the I<sup>2</sup>C status register (address 002D<sub>16</sub>) to generate a START condition. At this time, an SCL for 1 byte and an ACK clock automatically occur.
- ⑧ Set transmit data in the I<sup>2</sup>C data shift register (address 002B<sub>16</sub>). At this time, an SCL and an ACK clock automatically occur.
- ⑨ When transmitting control data of more than 1 byte, repeat step ⑧.
- ⑩ Set "D0<sub>16</sub>" in the I<sup>2</sup>C status register (address 002D<sub>16</sub>) to generate a STOP condition if ACK is not returned from slave reception side or transmission ends.

### Example of Slave Reception

An example of slave reception in the high-speed clock mode, at the SCL frequency of 400 kHz, in the ACK non-return mode and using the addressing format is shown below.

- ① Set a slave address in the high-order 7 bits of the I<sup>2</sup>C address register (address 002C<sub>16</sub>) and "0" in the RWB bit.
- ② Set the no ACK clock mode and SCL = 400 kHz by setting "25<sub>16</sub>" in the I<sup>2</sup>C clock control register (address 002F<sub>16</sub>).
- ③ Set "00<sub>16</sub>" in the I<sup>2</sup>C status register (address 002D<sub>16</sub>) so that transmission/reception mode can become initializing condition.
- ④ Set a communication enable status by setting "08<sub>16</sub>" in the I<sup>2</sup>C control register (address 002E<sub>16</sub>).
- ⑤ When a START condition is received, an address comparison is performed.
- ⑥ •When all transmitted addresses are "0" (general call):  
AD0 of the I<sup>2</sup>C status register (address 002D<sub>16</sub>) is set to "1" and an interrupt request signal occurs.  
• When the transmitted addresses agree with the address set in ①:  
AAS of the I<sup>2</sup>C status register (address 002D<sub>16</sub>) is set to "1" and an interrupt request signal occurs.  
• In the cases other than the above AD0 and AAS of the I<sup>2</sup>C status register (address 002D<sub>16</sub>) are set to "0" and no interrupt request signal occurs.
- ⑦ Set dummy data in the I<sup>2</sup>C data shift register (address 002B<sub>16</sub>).
- ⑧ When receiving control data of more than 1 byte, repeat step ⑦.
- ⑨ When a STOP condition is detected, the communication ends.

## ■Precautions when using multi-master I<sup>2</sup>C-BUS interface

### (1) Read-modify-write instruction

The precautions when the read-modify-write instruction such as SEB, CLB etc. is executed for each register of the multi-master I<sup>2</sup>C-BUS interface are described below.

- I<sup>2</sup>C data shift register (S0: address 002B<sub>16</sub>)  
When executing the read-modify-write instruction for this register during transfer, data may become a value not intended.
- I<sup>2</sup>C address register (S0D: address 002C<sub>16</sub>)  
When the read-modify-write instruction is executed for this register at detecting the STOP condition, data may become a value not intended. It is because H/W changes the read/write bit (RWB) at the above timing.
- I<sup>2</sup>C status register (S1: address 002D<sub>16</sub>)  
Do not execute the read-modify-write instruction for this register because all bits of this register are changed by H/W.
- I<sup>2</sup>C control register (S1D: address 002E<sub>16</sub>)  
When the read-modify-write instruction is executed for this register at detecting the START condition or at completing the byte transfer, data may become a value not intended. Because H/W changes the bit counter (BC0-BC2) at the above timing.
- I<sup>2</sup>C clock control register (S2: address 002F<sub>16</sub>)  
The read-modify-write instruction can be executed for this register.
- I<sup>2</sup>C START/STOP condition control register (S2D: address 0030<sub>16</sub>)  
The read-modify-write instruction can be executed for this register.

### (2) START condition generating procedure using multi-master

1. Procedure example (The necessary conditions of the generating procedure are described in Items 2 to 5 below.)

```

:
LDA —          (Taking out of slave address value)
SEI             (Interrupt disabled)
BBS 5, S1, BUSBUSY (BB flag confirming and branch process)
BUSFREE:
STA S0         (Writing of slave address value)
LDM #$F0, S1  (Trigger of START condition generating)
CLI           (Interrupt enabled)
:
BUSBUSY:
CLI           (Interrupt enabled)
:

```

2. Use "Branch on Bit Set" of "BBS 5, \$002D, -" for the BB flag confirming and branch process.
3. Use "STA \$2B, STX \$2B" or "STY \$2B" of the zero page addressing instruction for writing the slave address value to the I<sup>2</sup>C data shift register.
4. Execute the branch instruction of Item 2 and the store instruction of Item 3 continuously, as shown in the procedure example above.

5. Disable interrupts during the following three process steps:

- BB flag confirming
- Writing of slave address value
- Trigger of START condition generating

When the condition of the BB flag is bus busy, enable interrupts immediately.

(3) RESTART condition generating procedure

1. Procedure example (The necessary conditions for the procedure are described in items 2 to 4 below.)

Execute the following procedure when the PIN bit is "0."

```

:
LDM #$00, S1    (Select slave receive mode)
LDA —          (Take out of slave address value)
SEI             (Disable interrupt)
STA S0         (Write slave address value)
LDM #$F0, S1    (Trigger RESTART condition generation)
CLI           (Enable interrupt)
:

```

2. Select the slave receive mode when the PIN bit is "0." Do not write "1" to the PIN bit. Neither "0" nor "1" is specified as input to the BB bit.

The TRX bit becomes "0" and the SDA pin is released.

3. The SCL pin is released by writing the slave address value to the I<sup>2</sup>C data shift register.

4. Disable interrupts during the following two process steps:

- Write slave address value
- Trigger RESTART condition generation

(4) Writing to I<sup>2</sup>C status register

Do not execute an instruction to set the PIN bit to "1" from "0" and an instruction to set the MST and TRX bits to "0" from "1" simultaneously. Because it may enter the state that the SCL pin is released and the SDA pin is released after about one machine cycle. Do not execute an instruction to set the MST and TRX bits to "0" from "1" simultaneously when the PIN bit is "1." Because it may become the same as above.

(5) Process of after STOP condition generating

Do not write data in the I<sup>2</sup>C data shift register S0 and the I<sup>2</sup>C status register S1 until the bus busy flag BB becomes "0" after generating the STOP condition in the master mode. Because the STOP condition waveform might not be normally generated. Reading to the above registers do not have the problem.



**PULSE WIDTH MODULATION (PWM)**

The 7516 group (Spec. H) has a PWM function with an 8-bit resolution, based on a signal that is the clock input X<sub>IN</sub> or that clock input divided by 2.

**Data Setting**

The PWM output pin also functions as port P44. Set the PWM period by the PWM prescaler, and set the "H" term of output pulse by the PWM register.

If the value in the PWM prescaler is n and the value in the PWM register is m (where n = 0 to 255 and m = 0 to 255) :

$$\text{PWM period} = 255 \times (n+1) / f(X_{IN})$$

$$= 31.875 \times (n+1) \mu\text{s}$$

(when f(X<sub>IN</sub>) = 8 MHz, count source selection bit = "0")

$$\text{Output pulse "H" term} = \text{PWM period} \times m / 255$$

$$= 0.125 \times (n+1) \times m \mu\text{s}$$

(when f(X<sub>IN</sub>) = 8 MHz, count source selection bit = "0")

**PWM Operation**

When bit 0 (PWM enable bit) of the PWM control register is set to "1", operation starts by initializing the PWM output circuit, and pulses are output starting at an "H".

If the PWM register or PWM prescaler is updated during PWM output, the pulses will change in the cycle after the one in which the change was made.

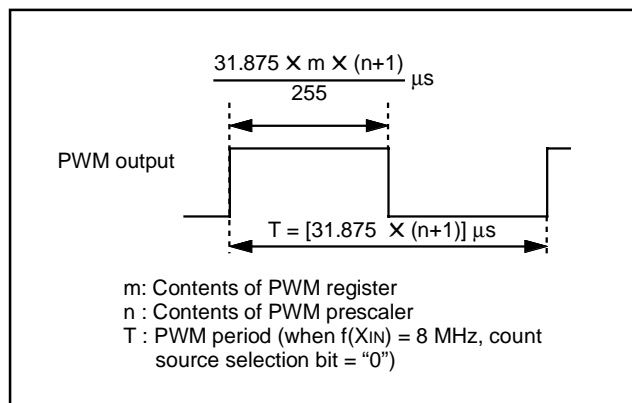

Fig. 40 Timing of PWM period

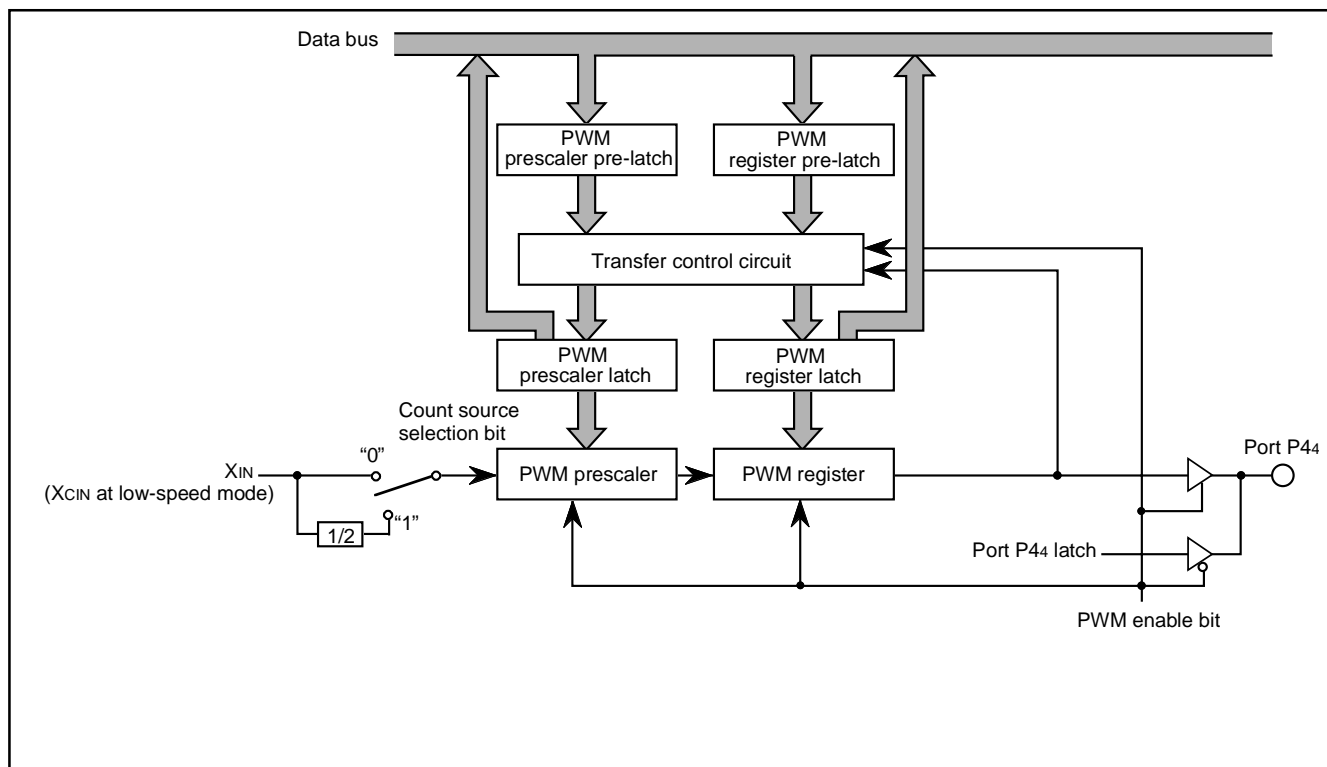

Fig. 41 Block diagram of PWM function

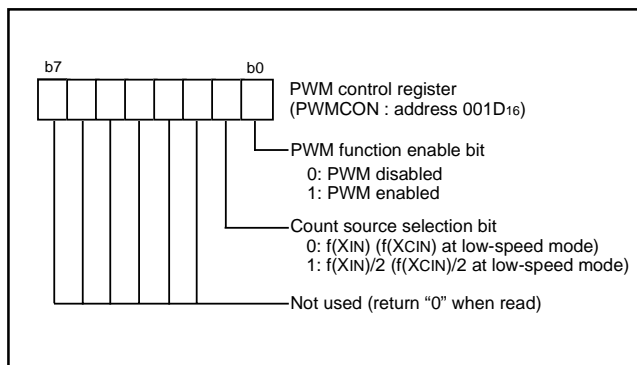

Fig. 42 Structure of PWM control register

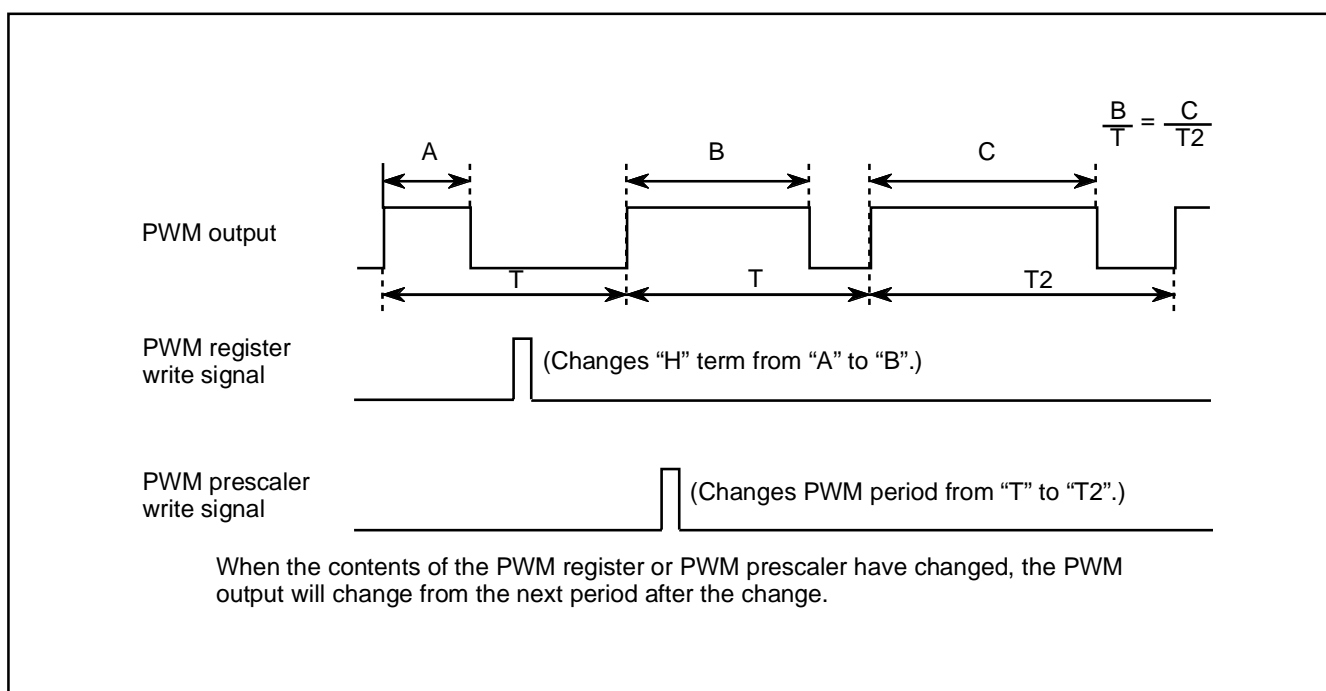

Fig. 43 PWM output timing when PWM register or PWM prescaler is changed

■Note

The PWM starts after the PWM function enable bit is set to enable and "L" level is output from the PWM pin. The length of this "L" level output is as follows:

$$\frac{n+1}{2 \cdot f(X_{IN})} \text{ sec} \quad (\text{Count source selection bit} = 0, \text{ where } n \text{ is the value set in the prescaler})$$

$$\frac{n+1}{f(X_{IN})} \text{ sec} \quad (\text{Count source selection bit} = 1, \text{ where } n \text{ is the value set in the prescaler})$$

**A-D CONVERTER**

**[A-D Conversion Registers (ADL, ADH)] 003516, 003616**

The A-D conversion registers are read-only registers that store the result of an A-D conversion. Do not read these registers during an A-D conversion.

**[AD Control Register (ADCON)] 003416**

The AD control register controls the A-D conversion process. Bits 0 to 2 select a specific analog input pin. Bit 4 indicates the completion of an A-D conversion. The value of this bit remains at "0" during an A-D conversion and changes to "1" when an A-D conversion ends. Writing "0" to this bit starts the A-D conversion.

**Comparison Voltage Generator**

The comparison voltage generator divides the voltage between AVSS and VREF into 1024 and outputs the divided voltages.

**Channel Selector**

The channel selector selects one of ports P30/AN0 to P35/AN5 and inputs the voltage to the comparator.

**Comparator and Control Circuit**

The comparator and control circuit compare an analog input voltage with the comparison voltage, and the result is stored in the A-D conversion registers. When an A-D conversion is completed, the control circuit sets the A-D conversion completion bit and the A-D interrupt request bit to "1".

Note that because the comparator consists of a capacitor coupling, set f(XIN) to 500 kHz or more during an A-D conversion.

When the A-D converter is operated at low-speed mode, f(XIN) and f(XCIN) do not have the lower limit of frequency, because of the A-D converter has a built-in self-oscillation circuit.

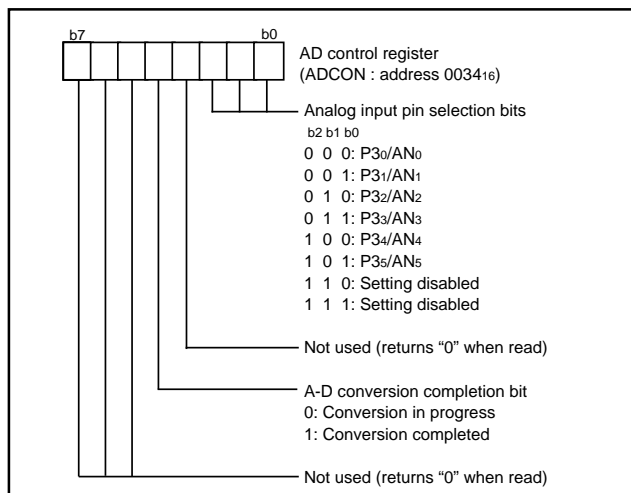

Fig. 44 Structure of AD control register

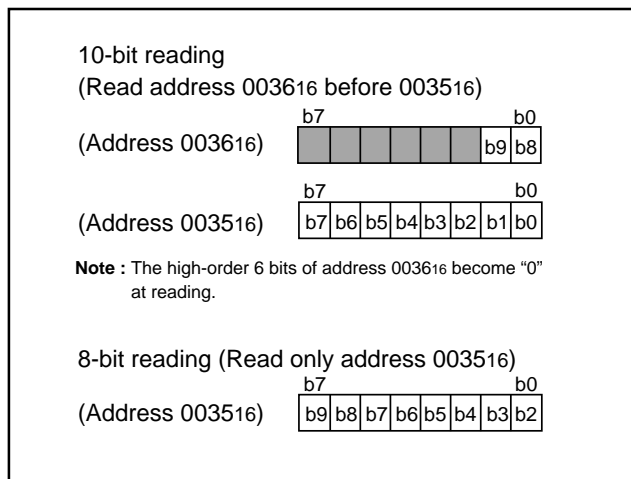

Fig. 45 Structure of A-D conversion registers

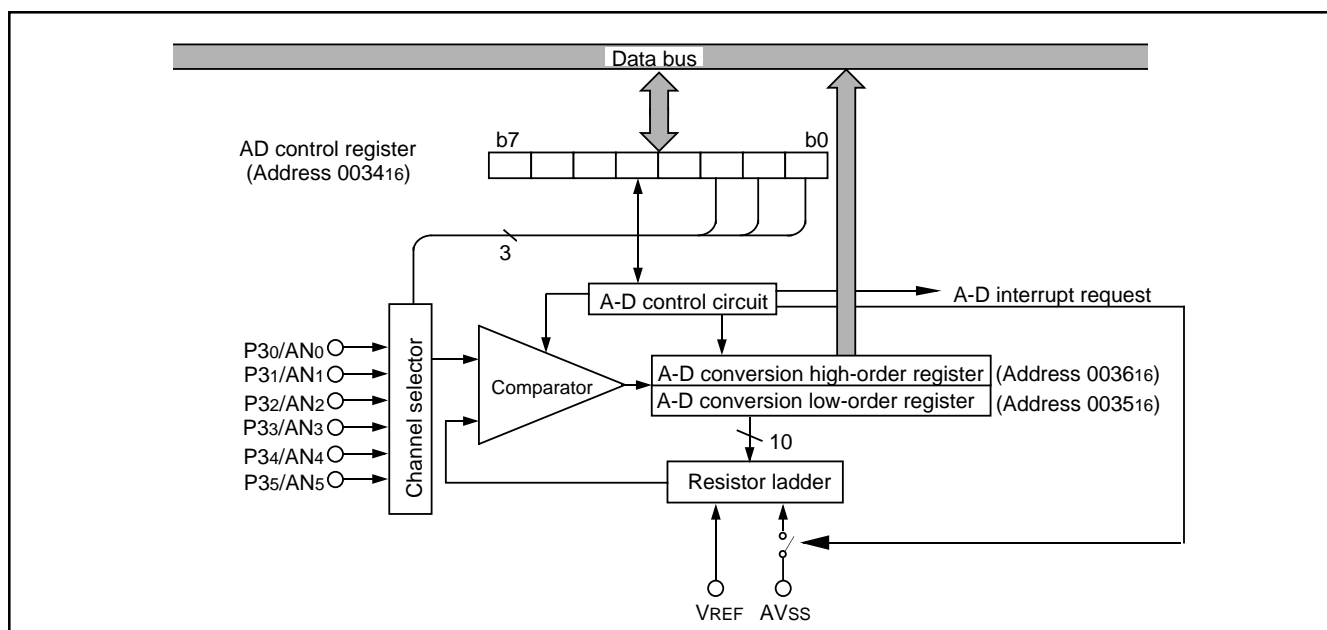

Fig. 46 Block diagram of A-D converter

## WATCHDOG TIMER

The watchdog timer gives a mean of returning to the reset status when a program cannot run on a normal loop (for example, because of a software run-away). The watchdog timer consists of an 8-bit watchdog timer L and an 8-bit watchdog timer H.

### Standard Operation of Watchdog Timer

When any data is not written into the watchdog timer control register (address 0039<sub>16</sub>) after reset, the watchdog timer is in the stop state. The watchdog timer starts to count down by writing an optional value into the watchdog timer control register (address 0039<sub>16</sub>) and an internal reset occurs at an underflow of the watchdog timer H.

Accordingly, programming is usually performed so that writing to the watchdog timer control register (address 0039<sub>16</sub>) may be started before an underflow. When the watchdog timer control register (address 0039<sub>16</sub>) is read, the values of the high-order 6 bits of the watchdog timer H, STP instruction disable bit, and watchdog timer H count source selection bit are read.

#### ●Initial value of watchdog timer

At reset or writing to the watchdog timer control register (address 0039<sub>16</sub>), each watchdog timer H and L are set to "FF<sub>16</sub>."

#### ●Watchdog timer H count source selection bit operation

Bit 7 of the watchdog timer control register (address 0039<sub>16</sub>) permits selecting a watchdog timer H count source. When this bit is set to "0", the count source becomes the underflow signal of watchdog timer L. The detection time is set to 131.072 ms at  $f(X_{IN}) = 8$  MHz frequency and 32.768 s at  $f(X_{CIN}) = 32$  kHz frequency. When this bit is set to "1", the count source becomes the signal divided by 16 for  $f(X_{IN})$  (or  $f(X_{CIN})$ ). The detection time in this case is set to 512  $\mu$ s at  $f(X_{IN}) = 8$  MHz frequency and 128 ms at  $f(X_{CIN}) = 32$  kHz frequency. This bit is cleared to "0" after reset.

#### ●Operation of STP instruction disable bit

Bit 6 of the watchdog timer control register (address 0039<sub>16</sub>) permits disabling the STP instruction when the watchdog timer is in operation.

When this bit is "0", the STP instruction is enabled.

When this bit is "1", the STP instruction is disabled, once the STP instruction is executed, an internal reset occurs. When this bit is set to "1", it cannot be rewritten to "0" by program. This bit is cleared to "0" after reset.

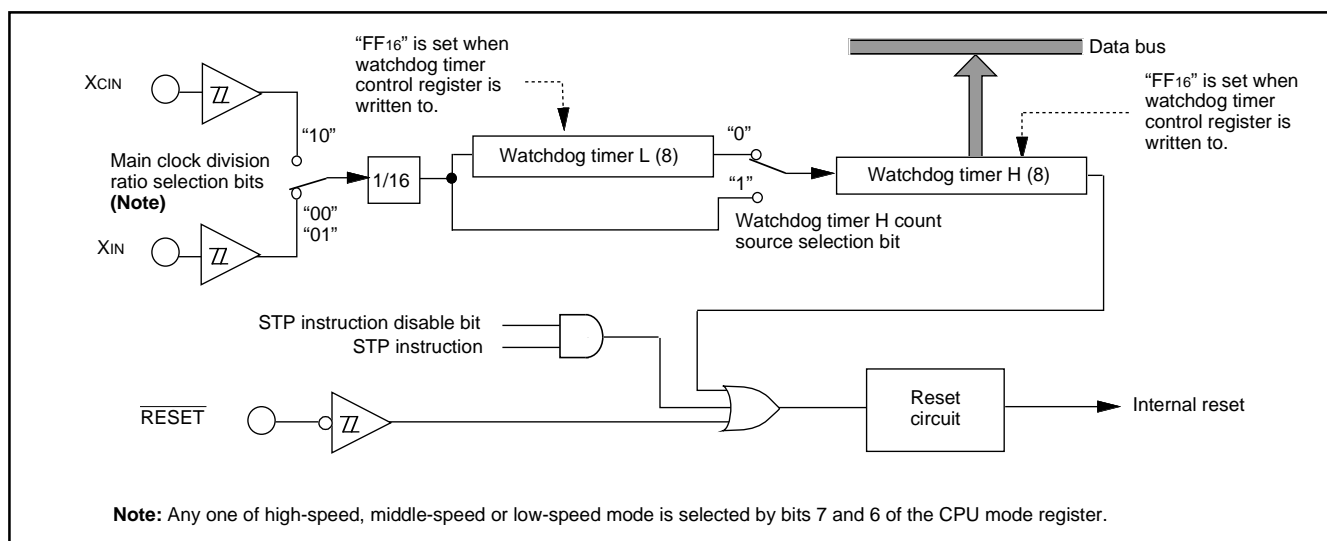

Fig. 47 Block diagram of Watchdog timer

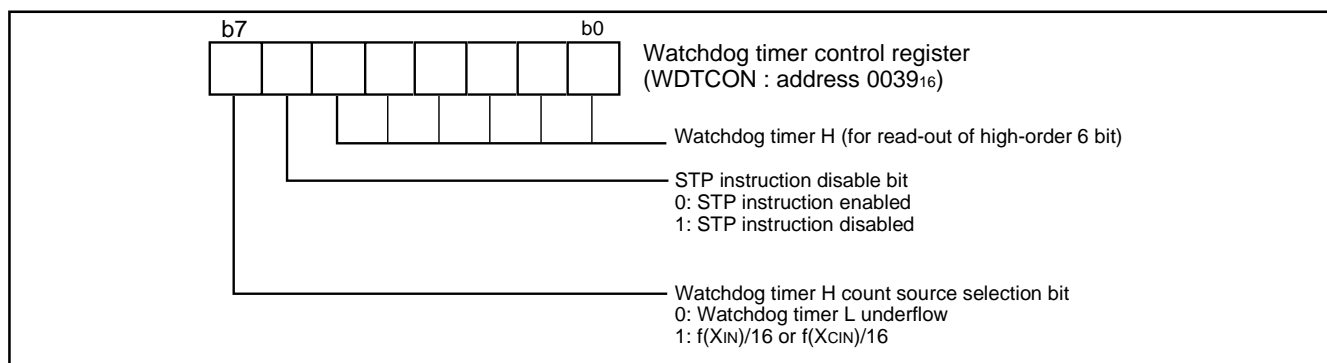

Fig. 48 Structure of Watchdog timer control register

**RESET CIRCUIT**

To reset the microcomputer,  $\overline{\text{RESET}}$  pin must be held at an "L" level for 20 cycles or more of  $X_{\text{IN}}$ . Then the  $\overline{\text{RESET}}$  pin is returned to an "H" level (the power source voltage must be between 2.7 V and 5.5 V, and the oscillation must be stable), reset is released. After the reset is completed, the program starts from the address FFFD<sub>16</sub> (high-order byte) and address FFFC<sub>16</sub> (low-order byte). Make sure that the reset input voltage is less than 0.54 V for  $V_{\text{CC}}$  of 2.7 V.

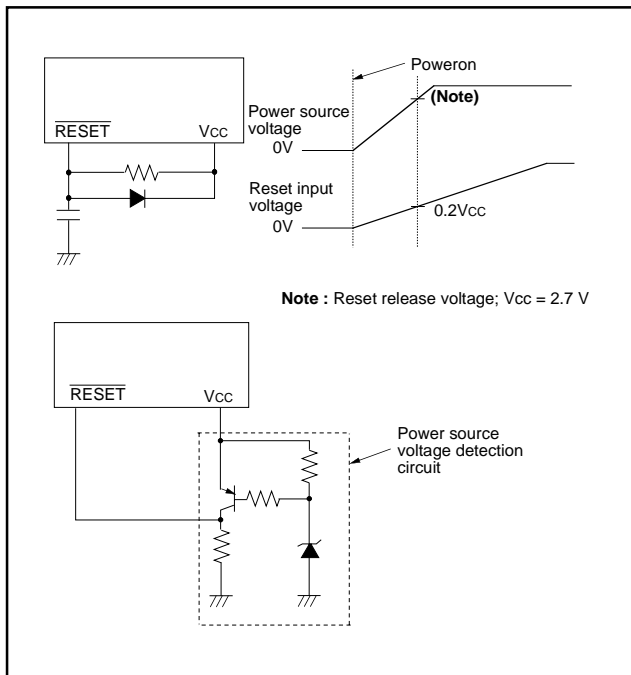

Fig. 49 Reset circuit example

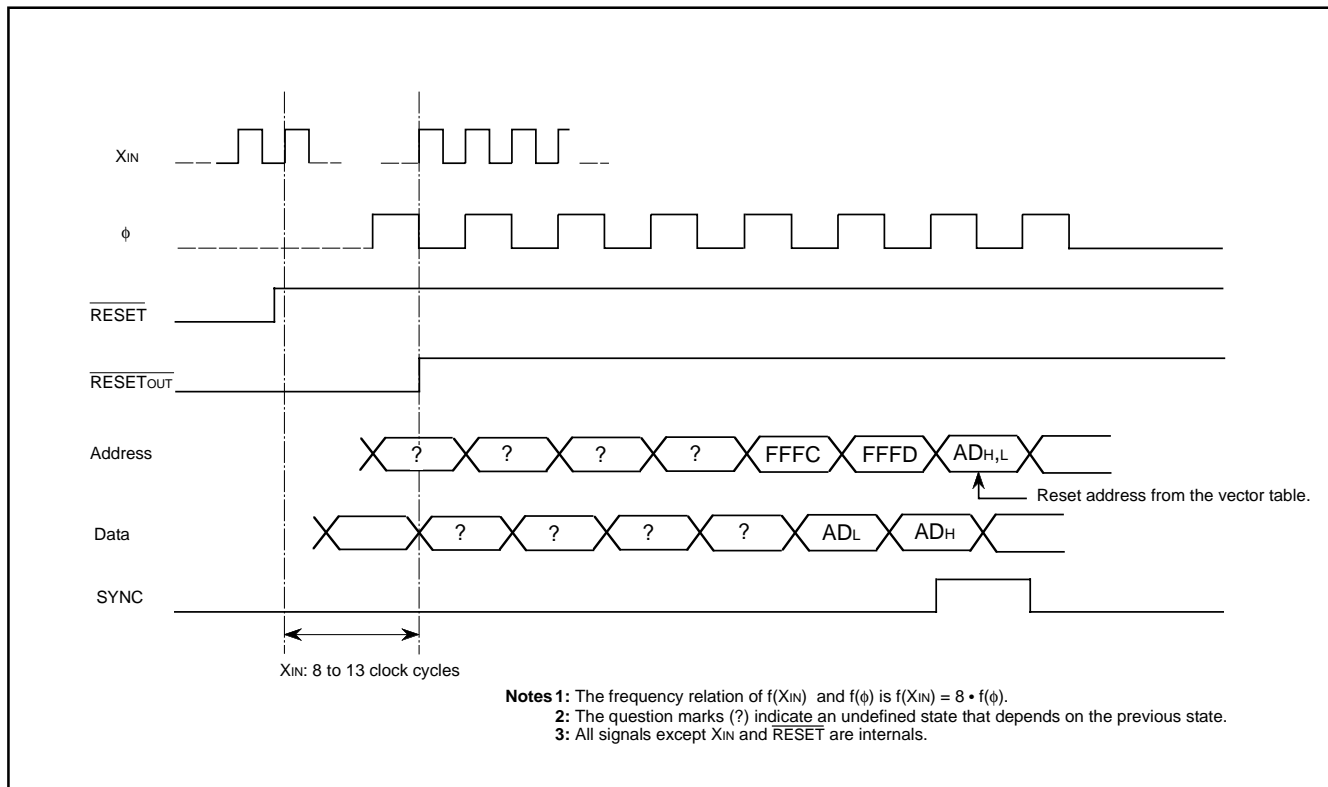

Fig. 50 Reset sequence

	Address	Register contents		Address	Register contents
(1) Port P0 (P0)	0000 <sub>16</sub>	00 <sub>16</sub>	(37) A-D control register (ADCON)	0034 <sub>16</sub>	00010000
(2) Port P0 direction register (P0D)	0001 <sub>16</sub>	00 <sub>16</sub>	(38) A-D conversion low-order register (ADL)	0035 <sub>16</sub>	XXXXXXXXXX
(3) Port P1 (P1)	0002 <sub>16</sub>	00 <sub>16</sub>	(39) A-D conversion high-order register (ADH)	0036 <sub>16</sub>	0000000X
(4) Port P1 direction register (P1D)	0003 <sub>16</sub>	00 <sub>16</sub>	(40) MISRG	0038 <sub>16</sub>	00 <sub>16</sub>
(5) Port P2 (P2)	0004 <sub>16</sub>	00 <sub>16</sub>	(41) Watchdog timer control register (WDTCON)	0039 <sub>16</sub>	00111111
(6) Port P2 direction register (P2D)	0005 <sub>16</sub>	00 <sub>16</sub>	(42) Interrupt edge selection register (INTEGE)	003A <sub>16</sub>	00 <sub>16</sub>
(7) Port P3 (P3)	0006 <sub>16</sub>	00 <sub>16</sub>	(43) CPU mode register (CPUM)	003B <sub>16</sub>	01001000
(8) Port P3 direction register (P3D)	0007 <sub>16</sub>	00 <sub>16</sub>	(44) Interrupt request register 1 (IREQ1)	003C <sub>16</sub>	00 <sub>16</sub>
(9) Port P4 (P4)	0008 <sub>16</sub>	00 <sub>16</sub>	(45) Interrupt request register 2 (IREQ2)	003D <sub>16</sub>	00 <sub>16</sub>
(10) Port P4 direction register (P4D)	0009 <sub>16</sub>	00 <sub>16</sub>	(46) Interrupt control register 1 (ICON1)	003E <sub>16</sub>	00 <sub>16</sub>
(11) Serial I/O2 control register 1 (SIO2CON1)	0015 <sub>16</sub>	00 <sub>16</sub>	(47) Interrupt control register 2 (ICON2)	003F <sub>16</sub>	00 <sub>16</sub>
(12) Serial I/O2 control register 2 (SIO2CON2)	0016 <sub>16</sub>	00000111	(48) Processor status register (PS)		XXXXXXXX1X
(13) Serial I/O2 register (SIO2)	0017 <sub>16</sub>	XXXXXXXXXX	(49) Program counter (PC <sub>H</sub> )		FFFD <sub>16</sub> contents
(14) Transmit/Receive buffer register (TB/RB)	0018 <sub>16</sub>	XXXXXXXXXX	(PC <sub>L</sub> )		FFFC <sub>16</sub> contents
(15) Serial I/O1 status register (SIOSTS)	0019 <sub>16</sub>	10000000	<b>Note</b> : X : Not fixed		
(16) Serial I/O1 control register (SIOCON)	001A <sub>16</sub>	00 <sub>16</sub>	Since the initial values for other than above mentioned registers and RAM contents are indefinite at reset, they must be set.		
(17) UART control register (UARTCON)	001B <sub>16</sub>	11100000			
(18) Baud rate generator (BRG)	001C <sub>16</sub>	XXXXXXXXXX			
(19) PWM control register (PWMCON)	001D <sub>16</sub>	00 <sub>16</sub>			
(20) PWM prescaler (PREPWM)	001E <sub>16</sub>	XXXXXXXXXX			
(21) PWM register (PWM)	001F <sub>16</sub>	XXXXXXXXXX			
(22) Prescaler 12 (PRE12)	0020 <sub>16</sub>	FF <sub>16</sub>			
(23) Timer 1 (T1)	0021 <sub>16</sub>	01 <sub>16</sub>			
(24) Timer 2 (T2)	0022 <sub>16</sub>	00 <sub>16</sub>			
(25) Timer XY mode register (TM)	0023 <sub>16</sub>	00 <sub>16</sub>			
(26) Prescaler X (PREX)	0024 <sub>16</sub>	FF <sub>16</sub>			
(27) Timer X (TX)	0025 <sub>16</sub>	FF <sub>16</sub>			
(28) Prescaler Y (PREY)	0026 <sub>16</sub>	FF <sub>16</sub>			
(29) Timer Y (TY)	0027 <sub>16</sub>	FF <sub>16</sub>			
(30) Timer count source selection register (TCSS)	0028 <sub>16</sub>	00 <sub>16</sub>			
(31) I <sup>2</sup> C data shift register (S0)	002B <sub>16</sub>	XXXXXXXXXX			
(32) I <sup>2</sup> C address register (S0D)	002C <sub>16</sub>	00 <sub>16</sub>			
(33) I <sup>2</sup> C status register (S1)	002D <sub>16</sub>	0001000X			
(34) I <sup>2</sup> C control register (S1D)	002E <sub>16</sub>	00 <sub>16</sub>			
(35) I <sup>2</sup> C clock control register (S2)	002F <sub>16</sub>	00 <sub>16</sub>			
(36) I <sup>2</sup> C start/stop condition control register (S2D)	0030 <sub>16</sub>	000XXXXX			

Fig. 51 Internal status at reset

**CLOCK GENERATING CIRCUIT**

The 7516 group (Spec H) has two built-in oscillation circuits: main clock X<sub>IN</sub>-X<sub>OUT</sub> oscillation circuit and sub clock X<sub>CIN</sub>-X<sub>COU</sub>T oscillation circuit. An oscillation circuit can be formed by connecting a resonator between X<sub>IN</sub> and X<sub>OUT</sub> (X<sub>CIN</sub> and X<sub>COU</sub>T). Use the circuit constants in accordance with the resonator manufacturer's recommended values. No external resistor is needed between X<sub>IN</sub> and X<sub>OUT</sub> since a feed-back resistor exists on-chip. However, an external feed-back resistor is needed between X<sub>CIN</sub> and X<sub>COU</sub>T. Immediately after power on, only the X<sub>IN</sub> oscillation circuit starts oscillating, and X<sub>CIN</sub> and X<sub>COU</sub>T pins function as I/O ports.

**Frequency Control**

**(1) Middle-speed mode**

The internal clock  $\phi$  is the frequency of X<sub>IN</sub> divided by 8. After reset is released, this mode is selected.

**(2) High-speed mode**

The internal clock  $\phi$  is half the frequency of X<sub>IN</sub>.

**(3) Low-speed mode**

The internal clock  $\phi$  is half the frequency of X<sub>CIN</sub>.

**■Note**

If you switch the mode between middle/high-speed and low-speed, stabilize both X<sub>IN</sub> and X<sub>CIN</sub> oscillations. The sufficient time is required for the sub-clock to stabilize, especially immediately after power on and at returning from the stop mode. When switching the mode between middle/high-speed and low-speed, set the frequency on condition that  $f(X_{IN}) > 3 \cdot f(X_{CIN})$ .

**(4) Low power dissipation mode**

The low power consumption operation can be realized by stopping the main clock X<sub>IN</sub> in low-speed mode. To stop the main clock, set bit 5 of the CPU mode register to "1." When the main clock X<sub>IN</sub> is restarted (by setting the main clock stop bit to "0"), set sufficient time for oscillation to stabilize.

The sub-clock X<sub>CIN</sub>-X<sub>COU</sub>T oscillation circuit can not directly input clocks that are generated externally. Accordingly, make sure to cause an external resonator to oscillate.

**Oscillation Control**

**(1) Stop mode**

If the STP instruction is executed, the internal clock  $\phi$  stops at an "H" level, and X<sub>IN</sub> and X<sub>CIN</sub> oscillation stops. When the oscillation stabilizing time set after STP instruction released bit is "0," the prescaler 12 is set to "FF<sub>16</sub>" and timer 1 is set to "01<sub>16</sub>." When the oscillation stabilizing time set after STP instruction released bit is "1," set the sufficient time for oscillation of used oscillator to stabilize since nothing is set to the prescaler 12 and timer 1.

Either X<sub>IN</sub> or X<sub>CIN</sub> divided by 16 is input to the prescaler 12 as count source. Oscillator restarts when an external interrupt is received, but the internal clock  $\phi$  is not supplied to the CPU (remains at "H") until timer 1 underflows. The internal clock  $\phi$  is supplied for the first time, when timer 1 underflows. This ensures time for the clock oscillation using the ceramic resonators to be stabilized. When the oscillator is restarted by reset, apply "L" level to the

RESET pin until the oscillation is stable since a wait time will not be generated.

**(2) Wait mode**

If the WIT instruction is executed, the internal clock  $\phi$  stops at an "H" level, but the oscillator does not stop. The internal clock  $\phi$  restarts at reset or when an interrupt is received. Since the oscillator does not stop, normal operation can be started immediately after the clock is restarted.

To ensure that the interrupts will be received to release the STP or WIT state, their interrupt enable bits must be set to "1" before executing of the STP or WIT instruction.

When releasing the STP state, the prescaler 12 and timer 1 will start counting the clock X<sub>IN</sub> divided by 16. Accordingly, set the timer 1 interrupt enable bit to "0" before executing the STP instruction.

**■Note**

When using the oscillation stabilizing time set after STP instruction released bit set to "1", evaluate time to stabilize oscillation of the used oscillator and set the value to the timer 1 and prescaler 12.

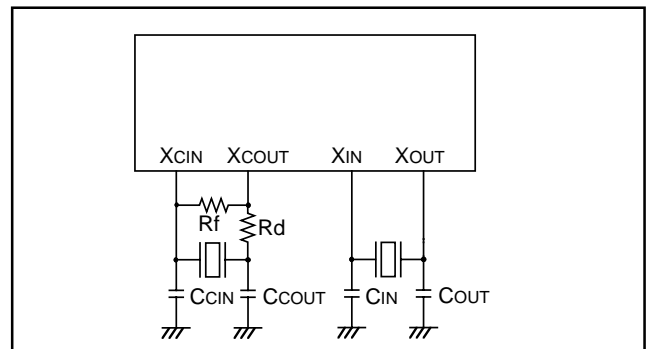

Fig. 52 Ceramic resonator circuit

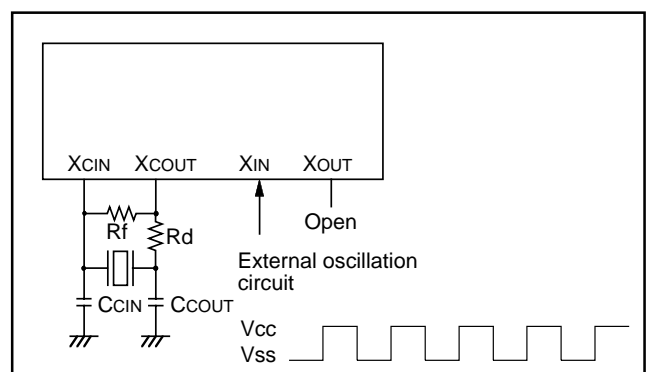

Fig. 53 External clock input circuit

**Notes on middle-speed mode automatic switch set bit**

When the middle-speed mode automatic switch set bit is set to "1" while operating in the low-speed mode, by detecting the rising/falling edge of the SCL or SDA pin, XIN oscillation automatically starts and the mode is automatically switched to the middle-speed mode. The timing which changes from the low-speed mode to the middle-speed mode can be set as 4.5 to 5.5 cycle, or 6.5 to 7.5 cycle in the low-speed mode by the middle-speed mode automatic switch waiting time set bit. Select according to the oscillation start characteristic of the XIN oscillator to be used.

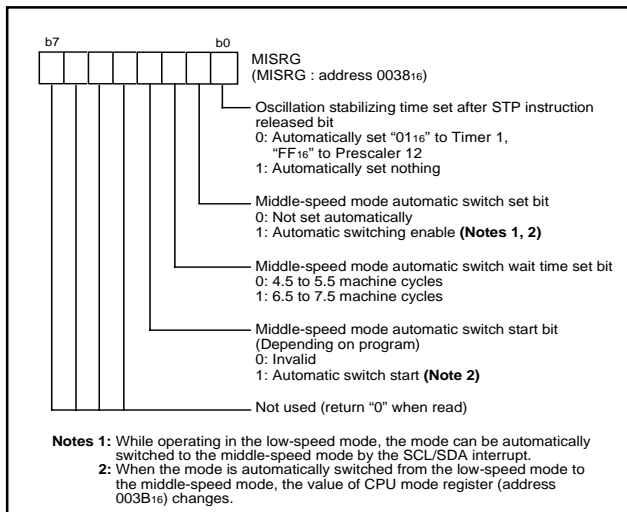

Fig. 54 Structure of MISRG

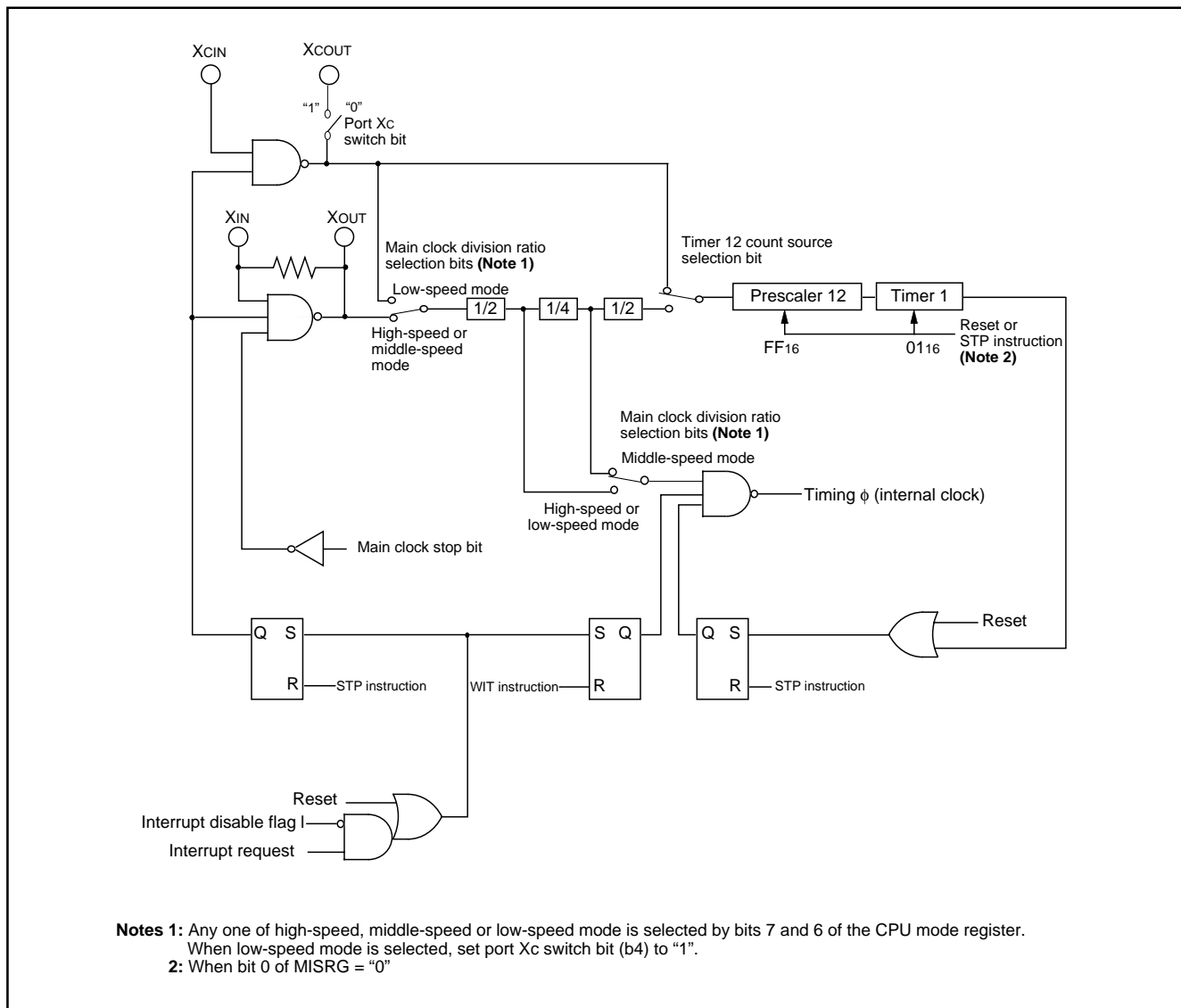
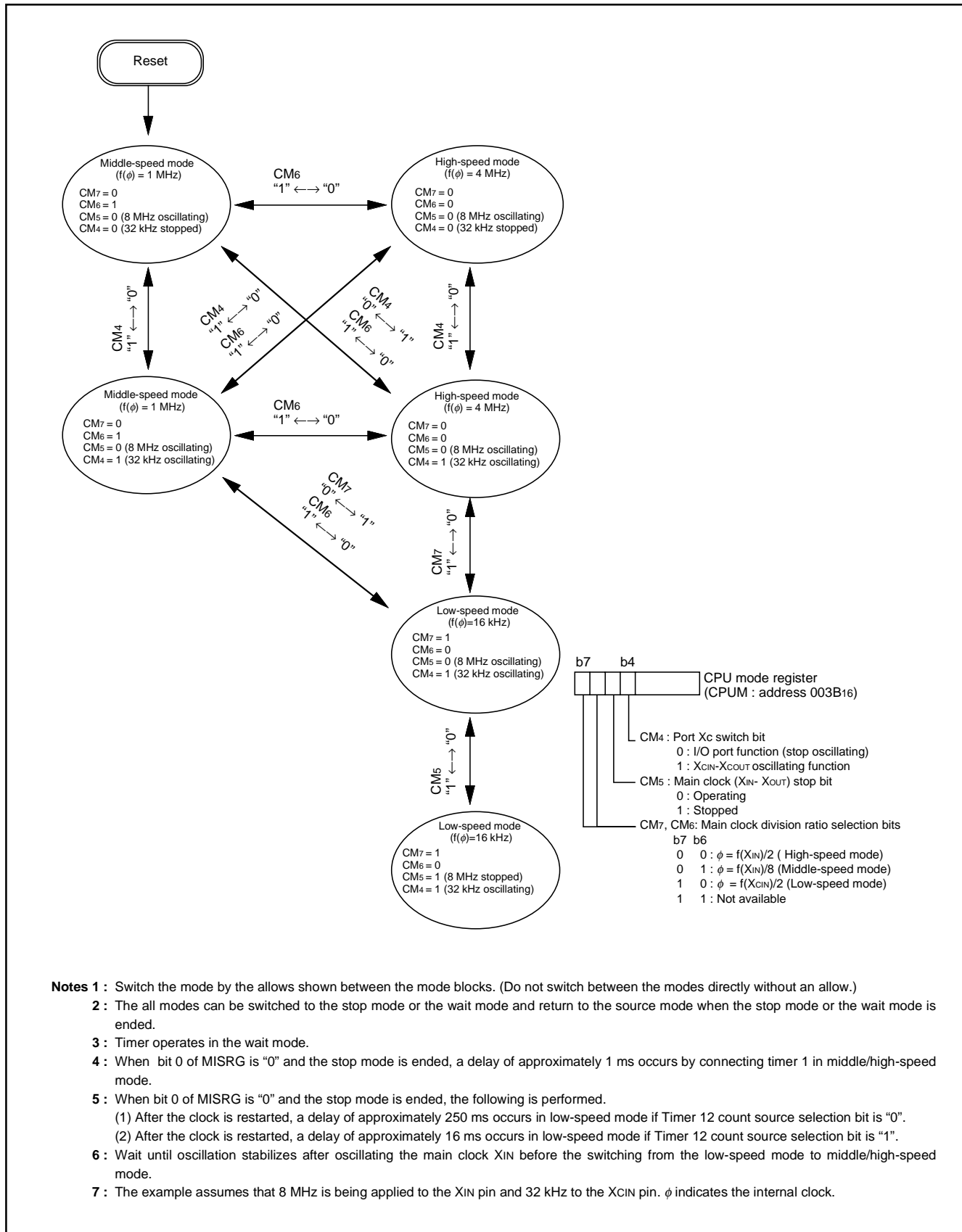

Fig. 55 System clock generating circuit block diagram (Single-chip mode)





- Notes 1 :** Switch the mode by the allows shown between the mode blocks. (Do not switch between the modes directly without an allow.)
- 2 :** The all modes can be switched to the stop mode or the wait mode and return to the source mode when the stop mode or the wait mode is ended.
- 3 :** Timer operates in the wait mode.
- 4 :** When bit 0 of MISRG is "0" and the stop mode is ended, a delay of approximately 1 ms occurs by connecting timer 1 in middle/high-speed mode.
- 5 :** When bit 0 of MISRG is "0" and the stop mode is ended, the following is performed.  
(1) After the clock is restarted, a delay of approximately 250 ms occurs in low-speed mode if Timer 12 count source selection bit is "0".  
(2) After the clock is restarted, a delay of approximately 16 ms occurs in low-speed mode if Timer 12 count source selection bit is "1".
- 6 :** Wait until oscillation stabilizes after oscillating the main clock X<sub>IN</sub> before the switching from the low-speed mode to middle/high-speed mode.
- 7 :** The example assumes that 8 MHz is being applied to the X<sub>IN</sub> pin and 32 kHz to the X<sub>CIN</sub> pin. φ indicates the internal clock.

Fig. 56 State transitions of system clock

**NOTES ON PROGRAMMING****Processor Status Register**

The contents of the processor status register (PS) after a reset are undefined, except for the interrupt disable flag (I) which is "1." After a reset, initialize flags which affect program execution. In particular, it is essential to initialize the index X mode (T) and the decimal mode (D) flags because of their effect on calculations.

**Interrupts**

The contents of the interrupt request bits do not change immediately after they have been written. After writing to an interrupt request register, execute at least one instruction before performing a BBC or BBS instruction.

**Decimal Calculations**

- To calculate in decimal notation, set the decimal mode flag (D) to "1", then execute an ADC or SBC instruction. After executing an ADC or SBC instruction, execute at least one instruction before executing a SEC, CLC, or CLD instruction.
- In decimal mode, the values of the negative (N), overflow (V), and zero (Z) flags are invalid.

**Timers**

If a value  $n$  (between 0 and 255) is written to a timer latch, the frequency division ratio is  $1/(n+1)$ .

**Multiplication and Division Instructions**

- The index X mode (T) and the decimal mode (D) flags do not affect the MUL and DIV instruction.
- The execution of these instructions does not change the contents of the processor status register.

**Ports**

The contents of the port direction registers cannot be read. The following cannot be used:

- The data transfer instruction (LDA, etc.)
- The operation instruction when the index X mode flag (T) is "1"
- The addressing mode which uses the value of a direction register as an index
- The bit-test instruction (BBC or BBS, etc.) to a direction register
- The read-modify-write instructions (ROR, CLB, or SEB, etc.) to a direction register.

Use instructions such as LDM and STA, etc., to set the port direction registers.

**Serial I/O**

In serial I/O1 (clock synchronous mode), if the receive side is using an external clock and it is to output the  $\overline{\text{SRDY}}_1$  signal, set the transmit enable bit, the receive enable bit, and the  $\overline{\text{SRDY}}_1$  output enable bit to "1."

Serial I/O1 continues to output the final bit from the TXD pin after transmission is completed.

SOUT2 pin for serial I/O2 goes to high impedance after transmission is completed.

When an external clock is used as synchronous clock in serial I/O1 or serial I/O2, write transmission data to the transmit buffer register or serial I/O2 register while the transfer clock is "H."

**A-D Converter**

The comparator uses capacitive coupling amplifier whose charge will be lost if the clock frequency is too low.

Therefore, make sure that  $f(\text{XIN})$  in the middle/high-speed mode is at least on 500 kHz during an A-D conversion.

Do not execute the STP instruction or the WIT instruction during an A-D conversion.

**Instruction Execution Time**

The instruction execution time is obtained by multiplying the frequency of the internal clock  $\phi$  by the number of cycles needed to execute an instruction.

The number of cycles required to execute an instruction is shown in the list of machine instructions.

The frequency of the internal clock  $\phi$  is half of the  $\text{XIN}$  frequency in high-speed mode.

**NOTES ON USAGE****Handling of Source Pins**

In order to avoid a latch-up occurrence, connect a capacitor suitable for high frequencies as bypass capacitor between power source pin (Vcc pin) and GND pin (Vss pin) and between power source pin (Vcc pin) and analog power source input pin (AVss pin). Besides, connect the capacitor to as close as possible. For bypass capacitor which should not be located too far from the pins to be connected, a ceramic capacitor of 0.01  $\mu\text{F}$ –0.1  $\mu\text{F}$  is recommended.

**EPROM Version/One Time PROM Version**

The CNVss pin is connected to the internal memory circuit block by a low-ohmic resistance, since it has the multiplexed function to be a programmable power source pin (VPP pin) as well.

To improve the noise reduction, connect a track between CNVss pin and Vss pin or Vcc pin with 1 to 10 k $\Omega$  resistance.

The mask ROM version track of CNVss pin has no operational interference even if it is connected to Vss pin or Vcc pin via a resistor.

**Electric Characteristic Differences between Mask ROM and One Time PROM Version MCUs**

There are differences in electric characteristics, operation margin, noise immunity, and noise radiation between mask ROM and One Time PROM version MCUs due to the differences in the manufacturing processes.

When manufacturing an application system with One Time PROM version and then switching to use of the mask ROM version, perform sufficient evaluations for the commercial samples of the mask ROM version.

**DATA REQUIRED FOR MASK ORDERS**

The following are necessary when ordering a mask ROM production:

1. Mask ROM Order Confirmation Form\*
2. Mark Specification Form\*
3. Data to be written to ROM, in EPROM form (three identical copies) or one floppy disk.

**DATA REQUIRED FOR One Time PROM PROGRAMMING ORDERS**

The following are necessary when ordering a PROM programming service:

1. ROM Programming Confirmation Form\*
2. Mark Specification Form\* (only special mark with customer's trade mark logo)
3. Data to be programmed to PROM, in EPROM form (three identical copies) or one floppy disk.

\*For the mask ROM confirmation and the mark specifications, refer to the "Mitsubishi MCU Technical Information" Homepage (<http://www.infocom.maec.co.jp/indexe.htm>).

**ROM PROGRAMMING METHOD**

The built-in PROM of the blank One Time PROM version and built-in EPROM version can be read or programmed with a general-purpose PROM programmer using a special programming adapter. Set the address of PROM programmer in the user ROM area.

**Table 13 Programming adapter**

Package	Name of Programming Adapter
44PJX-A	PCA7446

The PROM of the blank One Time PROM version is not tested or screened in the assembly process and following processes. To ensure proper operation after programming, the procedure shown in Figure 57 is recommended to verify programming.

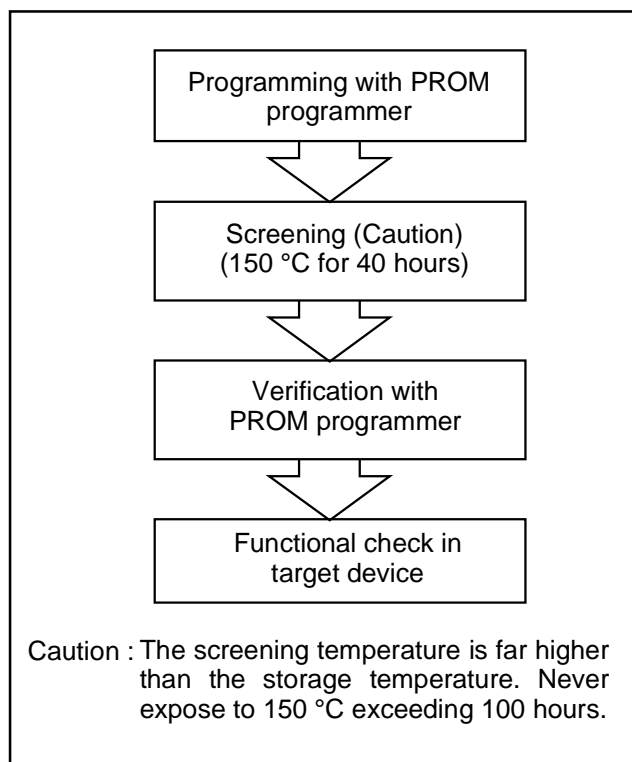

**Fig. 57 Programming and testing of One Time PROM version**

**ELECTRICAL CHARACTERISTICS**

**Table 14 Absolute maximum ratings**

Symbol	Parameter	Conditions	Ratings	Unit
VCC	Power source voltage		-0.3 to 6.5	V
Vi	Input voltage P00-P07, P10-P17, P20, P21, P24-P27, P30-P35, P40-P45, VREF	All voltages are based on Vss. Output transistors are cut off.	-0.3 to Vcc +0.3	V
Vi	Input voltage P22, P23		-0.3 to 5.8	V
Vi	Input voltage RESET, XIN		-0.3 to Vcc +0.3	V
Vi	Input voltage M37516M4H, M37516M6H		-0.3 to Vcc +0.3	V
	M37516E6H		-0.3 to 13	
Vo	Output voltage P00-P07, P10-P17, P20, P21, P24-P27, P30-P35, P40-P45, XOUT		-0.3 to Vcc +0.3	V
Vo	Output voltage P22, P23		-0.3 to 5.8	V
Pd	Power dissipation		Ta = 25 °C	300
Topr	Operating temperature		-20 to 85	°C
Tstg	Storage temperature		-40 to 125	°C

**Table 15 Recommended operating conditions (1)**

(Vcc = 2.7 to 5.5 V, Ta = -20 to 85 °C, unless otherwise noted)

Symbol	Parameter	Limits			Unit
		Min.	Typ.	Max.	
VCC	Power source voltage (At 8 MHz)	4.0	5.0	5.5	V
	Power source voltage (At 4 MHz)	2.7	5.0	5.5	
VSS	Power source voltage		0		V
VREF	A-D convert reference voltage	2.0		Vcc	V
AVSS	Analog power source voltage		0		V
VIA	Analog input voltage AN0-AN5	AVSS		Vcc	V
VIH	"H" input voltage P00-P07, P10-P17, P20-P27, P30-P35, P40-P45	0.8Vcc		Vcc	V
VIH	"H" input voltage (when I <sup>2</sup> C-BUS input level is selected) SDA1, SCL1	0.7Vcc		5.8	V
VIH	"H" input voltage (when I <sup>2</sup> C-BUS input level is selected) SDA2, SCL2	0.7Vcc		Vcc	V
VIH	"H" input voltage (when SMBUS input level is selected) SDA1, SCL1	1.4		5.8	V
VIH	"H" input voltage (when SMBUS input level is selected) SDA2, SCL2	1.4		Vcc	V
VIH	"H" input voltage RESET, XIN, CNVss	0.8Vcc		Vcc	V
VIL	"L" input voltage P00-P07, P10-P17, P20-P27, P30-P35, P40-P45	0		0.2Vcc	V
VIL	"L" input voltage (when I <sup>2</sup> C-BUS input level is selected) SDA1, SDA2, SCL1, SCL2	0		0.3Vcc	V
VIL	"L" input voltage (when SMBUS input level is selected) SDA1, SDA2, SCL1, SCL2	0		0.6	V
VIL	"L" input voltage RESET, CNVss	0		0.2Vcc	V
VIL	"L" input voltage XIN	0		0.16Vcc	V
ΣIOH(peak)	"H" total peak output current P00-P07, P10-P17, P30-P35 (Note)			-80	mA
ΣIOH(peak)	"H" total peak output current P20, P21, P24-P27, P40-P45 (Note)			-80	mA
ΣIOL(peak)	"L" total peak output current P00-P07, P30-P35 (Note)			80	mA
ΣIOL(peak)	"L" total peak output current P10-P17 (Note)			120	mA
ΣIOL(peak)	"L" total peak output current P20-P27, P40-P45 (Note)			80	mA
ΣIOH(avg)	"H" total average output current P00-P07, P10-P17, P30-P35 (Note)			-40	mA
ΣIOH(avg)	"H" total average output current P20, P21, P24-P27, P40-P45 (Note)			-40	mA
ΣIOL(avg)	"L" total average output current P00-P07, P30-P35 (Note)			40	mA
ΣIOL(avg)	"L" total average output current P10-P17 (Note)			60	mA
ΣIOL(avg)	"L" total average output current P20-P27, P40-P45 (Note)			40	mA

**Note :** The total output current is the sum of all the currents flowing through all the applicable ports. The total average current is an average value measured over 100 ms. The total peak current is the peak value of all the currents.

**Table 16 Recommended operating conditions (2)**  
 (VCC = 2.7 to 5.5 V, Ta = -20 to 85 °C, unless otherwise noted)

Symbol	Parameter	Limits			Unit
		Min.	Typ.	Max.	
IOH(peak)	"H" peak output current P00-P07, P10-P17, P20, P21, P24-P27, P30-P35, P40-P45 (Note 1)			-10	mA
IOL(peak)	"L" peak output current P00-P07, P20-P27, P30-P35, P40-P45 (Note 1)			10	mA
IOL(peak)	"L" peak output current P10-P17 (Note 1)			20	mA
IOH(avg)	"H" average output current P00-P07, P10-P17, P20, P21, P24-P27, P30-P35, P40-P45 (Note 2)			-5	mA
IOL(avg)	"L" average output current P00-P07, P20-P27, P30-P35, P40-P45 (Note 2)			5	mA
IOL(avg)	"L" peak output current P10-P17 (Note 2)			15	mA
f(XIN)	Internal clock oscillation frequency (VCC = 4.0 to 5.5V) (Note 3)			8	MHz
f(XIN)	Internal clock oscillation frequency (VCC = 2.7 to 5.5V) (Note 3)			4	MHz

- Notes** 1: The peak output current is the peak current flowing in each port.  
 2: The average output current IOL(avg), IOH(avg) are average value measured over 100 ms.  
 3: When the oscillation frequency has a duty cycle of 50%.

**Table 17 Electrical characteristics**  
 (VCC = 2.7 to 5.5 V, VSS = 0 V, Ta = -20 to 85 °C, unless otherwise noted)

Symbol	Parameter	Test conditions	Limits			Unit
			Min.	Typ.	Max.	
VOH	“H” output voltage P00–P07, P10–P17, P20, P21, P24–P27, P30–P35, P40–P45 <b>(Note)</b>	IOH = -10 mA VCC = 4.0–5.5 V	VCC-2.0			V
		IOH = -1.0 mA VCC = 2.7–5.5 V	VCC-1.0			V
VOL	“L” output voltage P00–P07, P20–P27, P30–P35, P40–P45	IOI = 10 mA VCC = 4.0–5.5 V			2.0	V
		IOI = 1.0 mA VCC = 2.7–5.5 V			1.0	V
VOL	“L” output voltage P10–P17	IOI = 20 mA VCC = 4.0–5.5 V			2.0	V
		IOI = 10 mA VCC = 2.7–5.5 V			1.0	V
VT+–VT-	Hysteresis CNTR0, CNTR1, INT0–INT3			0.4		V
VT+–VT-	Hysteresis RxD, SCLK			0.5		V
VT+–VT-	Hysteresis $\overline{\text{RESET}}$			0.5		V
IiH	“H” input current P00–P07, P10–P17, P20, P21, P24–P27, P30–P35, P40–P45	VI = VCC			5.0	μA
IiH	“H” input current $\overline{\text{RESET}}$ , CNVSS	VI = VCC			5.0	μA
IiH	“H” input current XIN	VI = VCC		4		μA
IiL	“L” input current P00–P07, P10–P17, P20–P27 P30–P35, P40–P45	VI = VSS			-5.0	μA
IiL	“L” input current $\overline{\text{RESET}}$ , CNVSS	VI = VSS			-5.0	μA
IiL	“L” input current XIN	VI = VSS		-4		μA
VRAM	RAM hold voltage	When clock stopped	2.0		5.5	V

**Note:** P25 is measured when the P25/TxD P-channel output disable bit of the UART control register (bit 4 of address 001B16) is “0”.

**Table 18 Electrical characteristics**  
 (V<sub>CC</sub> = 2.7 to 5.5 V, V<sub>SS</sub> = 0 V, T<sub>a</sub> = -20 to 85 °C, unless otherwise noted)

Symbol	Parameter	Test conditions	Limits			Unit	
			Min.	Typ.	Max.		
I <sub>CC</sub>	Power source current	High-speed mode f(X <sub>IN</sub> ) = 8 MHz f(XC <sub>IN</sub> ) = 32.768 kHz Output transistors "off"		6.8	13	mA	
		High-speed mode f(X <sub>IN</sub> ) = 8 MHz (in WIT state) f(XC <sub>IN</sub> ) = 32.768 kHz Output transistors "off"		1.6		mA	
		Low-speed mode f(X <sub>IN</sub> ) = stopped f(XC <sub>IN</sub> ) = 32.768 kHz Output transistors "off"		60	200	μA	
		Low-speed mode f(X <sub>IN</sub> ) = stopped f(XC <sub>IN</sub> ) = 32.768 kHz (in WIT state) Output transistors "off"		20	40	μA	
		Low-speed mode (V <sub>CC</sub> = 3 V) f(X <sub>IN</sub> ) = stopped f(XC <sub>IN</sub> ) = 32.768 kHz Output transistors "off"		20	55	μA	
		Low-speed mode (V <sub>CC</sub> = 3 V) f(X <sub>IN</sub> ) = stopped f(XC <sub>IN</sub> ) = 32.768 kHz (in WIT state) Output transistors "off"		5.0	10.0	μA	
		Middle-speed mode f(X <sub>IN</sub> ) = 8 MHz f(XC <sub>IN</sub> ) = stopped Output transistors "off"		4.0	7.0	mA	
		Middle-speed mode f(X <sub>IN</sub> ) = 8 MHz (in WIT state) f(XC <sub>IN</sub> ) = stopped Output transistors "off"		1.5		mA	
		Increment when A-D conversion is executed f(X <sub>IN</sub> ) = 8 MHz		800		μA	
		All oscillation stopped (in STP state) Output transistors "off"	T <sub>a</sub> = 25 °C		0.1	1.0	μA
			T <sub>a</sub> = 85 °C			10	μA

**Table 19 A-D converter characteristics**

(VCC = 2.7 to 5.5 V, VSS = AVSS = 0 V, Ta = -20 to 85 °C, f(XIN) = 8 MHz, f(XCIN) = 32 kHz, unless otherwise noted)

Symbol	Parameter	Test conditions	Limits			Unit	
			Min.	Typ.	Max.		
–	Resolution				10	bit	
–	Absolute accuracy (excluding quantization error)				±4	LSB	
tCONV	Conversion time	High-speed mode, middle-speed mode			61	tc(φ)	
		Low-speed mode		40		μs	
RLADDER	Ladder resistor			35		kΩ	
IVREF	Reference power source input current	VREF “on”	VREF = 5.0 V	50	150	200	μA
		VREF “off”				5.0	μA
Ii(AD)	A-D port input current			0.5	5.0	μA	



**TIMING REQUIREMENTS**

**Table 20 Timing requirements (1)**

(Vcc = 4.0 to 5.5 V, Vss = 0 V, Ta = -20 to 85 °C, unless otherwise noted)

Symbol	Parameter	Limits			Unit
		Min.	Typ.	Max.	
t <sub>w</sub> (RESET)	Reset input "L" pulse width	20			XIN cycles
t <sub>c</sub> (XIN)	External clock input cycle time	125			ns
t <sub>WH</sub> (XIN)	External clock input "H" pulse width	50			ns
t <sub>WL</sub> (XIN)	External clock input "L" pulse width	50			ns
t <sub>c</sub> (CNTR)	CNTR0, CNTR1 input cycle time	200			ns
t <sub>WH</sub> (CNTR)	CNTR0, CNTR1 input "H" pulse width	80			ns
t <sub>WL</sub> (CNTR)	CNTR0, CNTR1 input "L" pulse width	80			ns
t <sub>WH</sub> (INT)	INT0 to INT3 input "H" pulse width	80			ns
t <sub>WL</sub> (INT)	INT0 to INT3 input "L" pulse width	80			ns
t <sub>c</sub> (SCLK1)	Serial I/O1 clock input cycle time (Note)	800			ns
t <sub>WH</sub> (SCLK1)	Serial I/O1 clock input "H" pulse width (Note)	370			ns
t <sub>WL</sub> (SCLK1)	Serial I/O1 clock input "L" pulse width (Note)	370			ns
t <sub>su</sub> (RxD-SCLK1)	Serial I/O1 clock input set up time	220			ns
t <sub>h</sub> (SCLK1-RxD)	Serial I/O1 clock input hold time	100			ns
t <sub>c</sub> (SCLK2)	Serial I/O2 clock input cycle time	1000			ns
t <sub>WH</sub> (SCLK2)	Serial I/O2 clock input "H" pulse width	400			ns
t <sub>WL</sub> (SCLK2)	Serial I/O2 clock input "L" pulse width	400			ns
t <sub>su</sub> (SIN2-SCLK2)	Serial I/O2 clock input set up time	200			ns
t <sub>h</sub> (SCLK2-SIN2)	Serial I/O2 clock input hold time	200			ns

**Note :** When f(XIN) = 8 MHz and bit 6 of address 001A16 is "1" (clock synchronous).  
Divide this value by four when f(XIN) = 8 MHz and bit 6 of address 001A16 is "0" (UART).

**Table 21 Timing requirements (2)**

(Vcc = 2.7 to 5.5 V, Vss = 0 V, Ta = -20 to 85 °C, unless otherwise noted)

Symbol	Parameter	Limits			Unit
		Min.	Typ.	Max.	
t <sub>w</sub> (RESET)	Reset input "L" pulse width	20			XIN cycles
t <sub>c</sub> (XIN)	External clock input cycle time	250			ns
t <sub>WH</sub> (XIN)	External clock input "H" pulse width	100			ns
t <sub>WL</sub> (XIN)	External clock input "L" pulse width	100			ns
t <sub>c</sub> (CNTR)	CNTR0, CNTR1 input cycle time	500			ns
t <sub>WH</sub> (CNTR)	CNTR0, CNTR1 input "H" pulse width	230			ns
t <sub>WL</sub> (CNTR)	CNTR0, CNTR1 input "L" pulse width	230			ns
t <sub>WH</sub> (INT)	INT0 to INT3 input "H" pulse width	230			ns
t <sub>WL</sub> (INT)	INT0 to INT3 input "L" pulse width	230			ns
t <sub>c</sub> (SCLK1)	Serial I/O1 clock input cycle time (Note)	2000			ns
t <sub>WH</sub> (SCLK1)	Serial I/O1 clock input "H" pulse width (Note)	950			ns
t <sub>WL</sub> (SCLK1)	Serial I/O1 clock input "L" pulse width (Note)	950			ns
t <sub>su</sub> (RxD-SCLK1)	Serial I/O1 clock input set up time	400			ns
t <sub>h</sub> (SCLK1-RxD)	Serial I/O1 clock input hold time	200			ns
t <sub>c</sub> (SCLK2)	Serial I/O2 clock input cycle time	2000			ns
t <sub>WH</sub> (SCLK2)	Serial I/O2 clock input "H" pulse width	950			ns
t <sub>WL</sub> (SCLK2)	Serial I/O2 clock input "L" pulse width	950			ns
t <sub>su</sub> (SIN2-SCLK2)	Serial I/O2 clock input set up time	400			ns
t <sub>h</sub> (SCLK2-SIN2)	Serial I/O2 clock input hold time	300			ns

**Note :** When f(XIN) = 4 MHz and bit 6 of address 001A16 is "1" (clock synchronous).  
Divide this value by four when f(XIN) = 8 MHz and bit 6 of address 001A16 is "0" (UART).

**Table 22 Switching characteristics 1**

(V<sub>CC</sub> = 4.0 to 5.5 V, V<sub>SS</sub> = 0 V, T<sub>a</sub> = -20 to 85 °C, unless otherwise noted)

Symbol	Parameter	Test conditions	Limits			Unit
			Min.	Typ.	Max.	
t <sub>WH</sub> (SCLK1)	Serial I/O1 clock output "H" pulse width	Fig. 59	t <sub>c</sub> (SCLK1)/2-30			ns
t <sub>WL</sub> (SCLK1)	Serial I/O1 clock output "L" pulse width		t <sub>c</sub> (SCLK1)/2-30			ns
t <sub>d</sub> (SCLK1-TxD)	Serial I/O1 output delay time (Note 1)				140	ns
t <sub>v</sub> (SCLK1-TxD)	Serial I/O1 output valid time (Note 1)		-30			ns
t <sub>r</sub> (SCLK1)	Serial I/O1 clock output rising time				30	ns
t <sub>f</sub> (SCLK1)	Serial I/O1 clock output falling time				30	ns
t <sub>WH</sub> (SCLK2)	Serial I/O2 clock output "H" pulse width		t <sub>c</sub> (SCLK2)/2-160			ns
t <sub>WL</sub> (SCLK2)	Serial I/O2 clock output "L" pulse width		t <sub>c</sub> (SCLK2)/2-160			ns
t <sub>d</sub> (SCLK2-SOUT2)	Serial I/O2 output delay time (Note 2)				200	ns
t <sub>v</sub> (SCLK2-SOUT2)	Serial I/O2 output valid time (Note 2)		0			ns
t <sub>f</sub> (SCLK2)	Serial I/O2 clock output falling time				30	ns
t <sub>r</sub> (CMOS)	CMOS output rising time (Note 3)			10	30	ns
t <sub>f</sub> (CMOS)	CMOS output falling time (Note 3)			10	30	ns

**Notes** 1: For t<sub>WH</sub>(SCLK1), t<sub>WL</sub>(SCLK1), when the P25/TxD P-channel output disable bit of the UART control register (bit 4 of address 001B16) is "0".  
 2: When the P01/SOUT2 and P02/SCLK2 P-channel output disable bit of the Serial I/O2 control register (bit 7 of address 001516) is "0".  
 3: The XOUT pin is excluded.

**Table 23 Switching characteristics 2**

(V<sub>CC</sub> = 2.7 to 5.5 V, V<sub>SS</sub> = 0 V, T<sub>a</sub> = -20 to 85 °C, unless otherwise noted)

Symbol	Parameter	Test conditions	Limits			Unit
			Min.	Typ.	Max.	
t <sub>WH</sub> (SCLK1)	Serial I/O1 clock output "H" pulse width	Fig. 59	t <sub>c</sub> (SCLK1)/2-50			ns
t <sub>WL</sub> (SCLK1)	Serial I/O1 clock output "L" pulse width		t <sub>c</sub> (SCLK1)/2-50			ns
t <sub>d</sub> (SCLK1-TxD)	Serial I/O1 output delay time (Note 1)				350	ns
t <sub>v</sub> (SCLK1-TxD)	Serial I/O1 output valid time (Note 1)		-30			ns
t <sub>r</sub> (SCLK1)	Serial I/O1 clock output rising time				50	ns
t <sub>f</sub> (SCLK1)	Serial I/O1 clock output falling time				50	ns
t <sub>WH</sub> (SCLK2)	Serial I/O2 clock output "H" pulse width		t <sub>c</sub> (SCLK2)/2-240			ns
t <sub>WL</sub> (SCLK2)	Serial I/O2 clock output "L" pulse width		t <sub>c</sub> (SCLK2)/2-240			ns
t <sub>d</sub> (SCLK2-SOUT2)	Serial I/O2 output delay time (Note 2)				400	ns
t <sub>v</sub> (SCLK2-SOUT2)	Serial I/O2 output valid time (Note 2)		0			ns
t <sub>f</sub> (SCLK2)	Serial I/O2 clock output falling time				50	ns
t <sub>r</sub> (CMOS)	CMOS output rising time (Note 3)			20	50	ns
t <sub>f</sub> (CMOS)	CMOS output falling time (Note 3)			20	50	ns

**Notes** 1: For t<sub>WH</sub>(SCLK1), t<sub>WL</sub>(SCLK1), when the P25/TxD P-channel output disable bit of the UART control register (bit 4 of address 001B16) is "0".  
 2: When the P01/SOUT2 and P02/SCLK2 P-channel output disable bit of the Serial I/O2 control register (bit 7 of address 001516) is "0".  
 3: The XOUT pin is excluded.

**MULTI-MASTER I<sup>2</sup>C-BUS BUS LINE CHARACTERISTICS**

**Table 24 Multi-master I<sup>2</sup>C-BUS bus line characteristics**

Symbol	Parameter	Standard clock mode		High-speed clock mode		Unit
		Min.	Max.	Min.	Max.	
t <sub>BUF</sub>	Bus free time	4.7		1.3		μs
t <sub>HD;STA</sub>	Hold time for START condition	4.0		0.6		μs
t <sub>LOW</sub>	Hold time for SCL clock = "0"	4.7		1.3		μs
t <sub>R</sub>	Rising time of both SCL and SDA signals		1000	20+0.1C <sub>b</sub>	300	ns
t <sub>HD;DAT</sub>	Data hold time	0		0	0.9	μs
t <sub>HIGH</sub>	Hold time for SCL clock = "1"	4.0		0.6		μs
t <sub>F</sub>	Falling time of both SCL and SDA signals		300	20+0.1C <sub>b</sub>	300	ns
t <sub>SU;DAT</sub>	Data setup time	250		100		ns
t <sub>SU;STA</sub>	Setup time for repeated START condition	4.7		0.6		μs
t <sub>SU;STO</sub>	Setup time for STOP condition	4.0		0.6		μs

**Note:** C<sub>b</sub> = total capacitance of 1 bus line

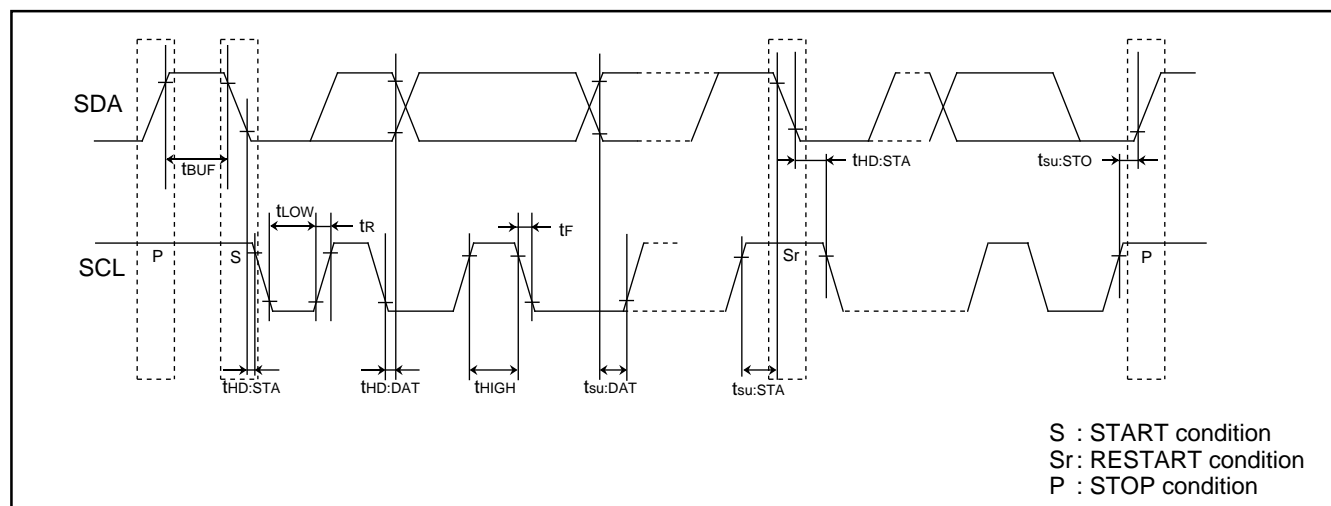

**Fig. 58 Timing diagram of multi-master I<sup>2</sup>C-BUS**

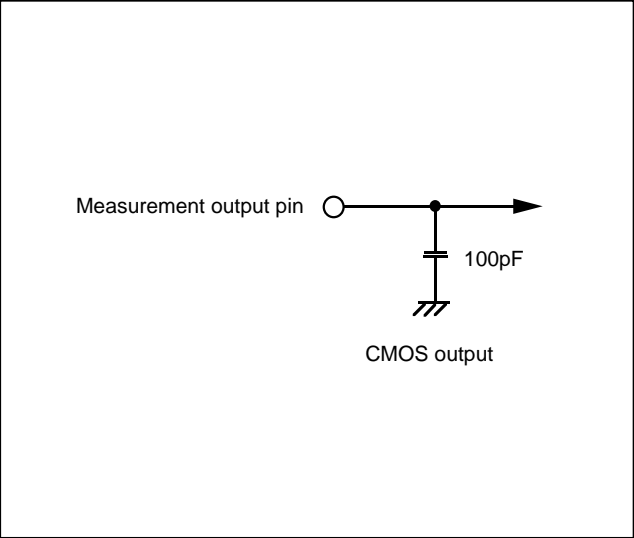

Fig. 59 Circuit for measuring output switching characteristics (1)

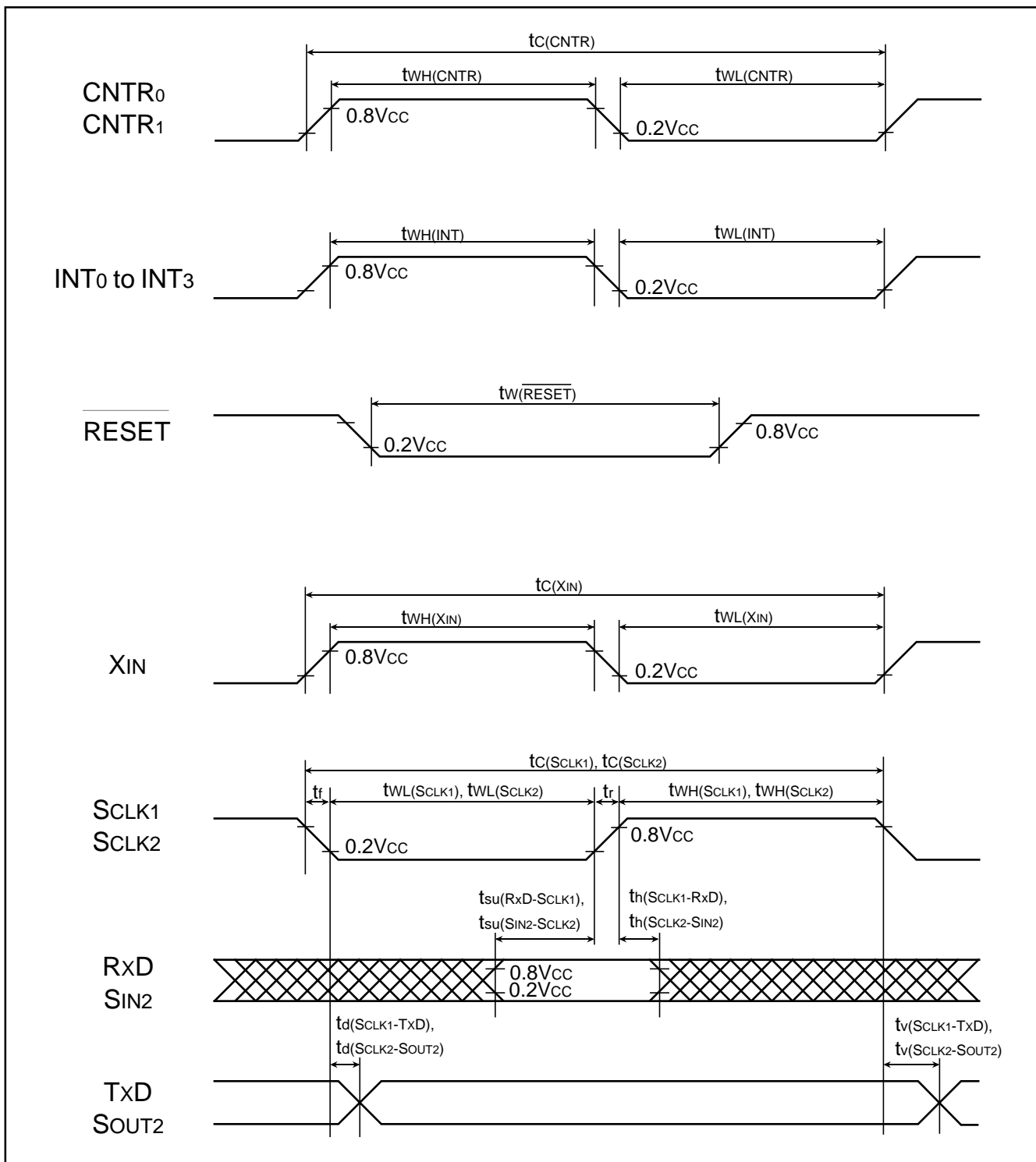

Fig. 60 Timing diagram

## Renesas Technology Corp.

Nippon Bldg.,6-2,Otemachi 2-chome,Chiyoda-ku,Tokyo,100-0004 Japan

### Keep safety first in your circuit designs!

- Mitsubishi Electric Corporation puts the maximum effort into making semiconductor products better and more reliable, but there is always the possibility that trouble may occur with them. Trouble with semiconductors may lead to personal injury, fire or property damage. Remember to give due consideration to safety when making your circuit designs, with appropriate measures such as (i) placement of substitutive, auxiliary circuits, (ii) use of non-flammable material or (iii) prevention against any malfunction or mishap.

### Notes regarding these materials

- These materials are intended as a reference to assist our customers in the selection of the Mitsubishi semiconductor product best suited to the customer's application; they do not convey any license under any intellectual property rights, or any other rights, belonging to Mitsubishi Electric Corporation or a third party.
- Mitsubishi Electric Corporation assumes no responsibility for any damage, or infringement of any third-party's rights, originating in the use of any product data, diagrams, charts, programs, algorithms, or circuit application examples contained in these materials.
- All information contained in these materials, including product data, diagrams, charts, programs and algorithms represents information on products at the time of publication of these materials, and are subject to change by Mitsubishi Electric Corporation without notice due to product improvements or other reasons. It is therefore recommended that customers contact Mitsubishi Electric Corporation or an authorized Mitsubishi Semiconductor product distributor for the latest product information before purchasing a product listed herein. The information described here may contain technical inaccuracies or typographical errors. Mitsubishi Electric Corporation assumes no responsibility for any damage, liability, or other loss rising from these inaccuracies or errors. Please also pay attention to information published by Mitsubishi Electric Corporation by various means, including the Mitsubishi Semiconductor home page (<http://www.mitsubishichips.com>).
- When using any or all of the information contained in these materials, including product data, diagrams, charts, programs, and algorithms, please be sure to evaluate all information as a total system before making a final decision on the applicability of the information and products. Mitsubishi Electric Corporation assumes no responsibility for any damage, liability or other loss resulting from the information contained herein.
- Mitsubishi Electric Corporation semiconductors are not designed or manufactured for use in a device or system that is used under circumstances in which human life is potentially at stake. Please contact Mitsubishi Electric Corporation or an authorized Mitsubishi Semiconductor product distributor when considering the use of a product contained herein for any specific purposes, such as apparatus or systems for transportation, vehicular, medical, aerospace, nuclear, or undersea repeater use.
- The prior written approval of Mitsubishi Electric Corporation is necessary to reprint or reproduce in whole or in part these materials.
- If these products or technologies are subject to the Japanese export control restrictions, they must be exported under a license from the Japanese government and cannot be imported into a country other than the approved destination. Any diversion or reexport contrary to the export control laws and regulations of Japan and/or the country of destination is prohibited.
- Please contact Mitsubishi Electric Corporation or an authorized Mitsubishi Semiconductor product distributor for further details on these materials or the products contained therein.

