

## PAP7501V USB2.0 PC Camera Controller

### General Description

The PAP7501V High-Speed USB2.0 Camera Controller is a highly integrated and cost-effective solution for USB2.0 PC-Camera based applications. It is fully compliant with USB Video Class 1.1 and USB audio class 1.0 standard. Internal controller can be power-up loaded from external EEPROM. This allows customization of VID, PID, product string, sensor parameters...etc.

### Features

#### .USB Features

- USB 2.0 and 1.1 compliance (high speed and full speed transceiver).
- USB video class 1.1 compliance.
- USB audio class 1.0 compliance.

#### .Micro Controller Features

- Built-in 8 bit micro controller with 40K-byte of mask ROM and 24K-byte SRAM.
- Firmware supports AE, AWB, and USB protocol.
- Programmable codes uploaded from serial EEPROM/Flash.

#### .Sensor Controller Features.

- Support up to VGA CMOS image sensors.
- Support 8 bit raw image data or YUV2 input from CMOS sensor.
- On chip color processor engine.
- Built-in MJPEG encoder.
- Support 2 wires serial interface for sensor control.

#### . Audio Controller Features

- Audio interface: -Built in 10 bit mono audio ADC for audio recording through microphone.
- -Sampling rate @16/48kHz, resolution 16 bits format.
- Recording, mute and volume control.

#### . Miscellaneous Features

- Power consumption: < 100mA
- USB 5V power in, on-chip 3.3V regulator for IO PAD and PHY, on-chip 1.8V regulator for core logic.

### Key Specification

Supply Voltage	5.0V ± 10%
Resolution	Up to 640 (H) x 480 (V)
Frame Rate	Up to 30fps
System Clock	12MHz
Power consumption	<100mA

### Ordering Information

Order number	Package Type	Package Size(mm)
PAP7501V	48-pin QFN	5.53 x 5.53

## 1. Pin Assignment

Pin#	Name	Type	Description
1	GND33A_PLL_I	GND	Ground for PLL
2	VDD5MA	PWR	5V Power for analog circuit
3	VDD28A_MIC	BYPASS	Analog power for Audio MIC, 2.8V
4	VCOM	BYPASS	Microphone common mode voltage reference
5	MIC_P	IN	Microphone positive input
6	MIC_N	IN	Microphone negative input
7	VDD33A_PGA	BYPASS	Analog power for Audio PGA, 3.3V
8	VSSA	GND	Microphone GND
9	VDD33A_ADC	BYPASS	Analog power for Audio ADC, 3.3V
10	VSSQ	GND	Digital ground
11	RSTN	IN	Chip power up reset (Internal pull-up 100Kohm)
12	SEN_CSB	OUT	Chip select of EEPROM
13	KEY	IN	Snapshot control signal (Active Low, internal pull-up 100Kohm)
14	GPIO4	I/O	General purpose I/O
15	VDD18K	BYPASS	Logic power for digit circuit, 1.8V
16	VDD33Q	BYPASS	Logic power for digit circuit, 3.3V
17	SEN_CLK	OUT	Clock output for sensor
18	SEN_SCL	OUT	I2C clock
19	SEN_SDA	I/O	I2C data
20	I_VSYNC	IN	Vertical synchronization signal
21	I_HSYNC	IN	Horizontal synchronization signal
22	EPR_CSB	IN	Chip Select of EEPROM
23	EPR_SO	IN	Data out of EEPROM
24	EPR_SI	OUT	Data input of EEPROM
25	EPR_SCK	OUT	Serial clock of EEPROM
26	I_PXD7	IN	Sensor digital data input
27	I_PXD6	IN	Sensor digital data input
28	I_PXD5	IN	Sensor digital data input
29	I_PXD4	IN	Sensor digital data input
30	I_PXD3	IN	Sensor digital data input
31	I_PXD2	IN	Sensor digital data input
32	I_PXD1	IN	Sensor digital data input
33	I_PXD0	IN	Sensor digital data input
34	I_PXCLK	IN	Sensor pixel clock input
35	VDD5MD	PWR	5V power for digit circuit
36	VDDAYS	BYPASS	Logic power for digit circuit, 2.5V
37	VDD5MV	PWR	5V power for PHY circuit
38	VSSQ	GND	Digital ground
39	VDD33A_HSRT_O	BYPASS	Analog power for TX/RX
40	VDD18K	BYPASS	Logic power for digit circuit, 1.8V
41	OSC_IN	IN	Crystal input
42	OSC_OUT	OUT	Crystal output
43	VDD33A_HSRT_I	BYPASS	Analog power for TX/RX
44	GND33A_HSRT_I	GND	Ground for USB TX/RX
45	RRET	IN	Reference supply current for PHY
46	DM	I/O	DM for USB PHY
47	DP	I/O	DP for USB PHY
48	VDD33A_PLL_I	BYPASS	Analog power for PLL

## 2. Block Diagram

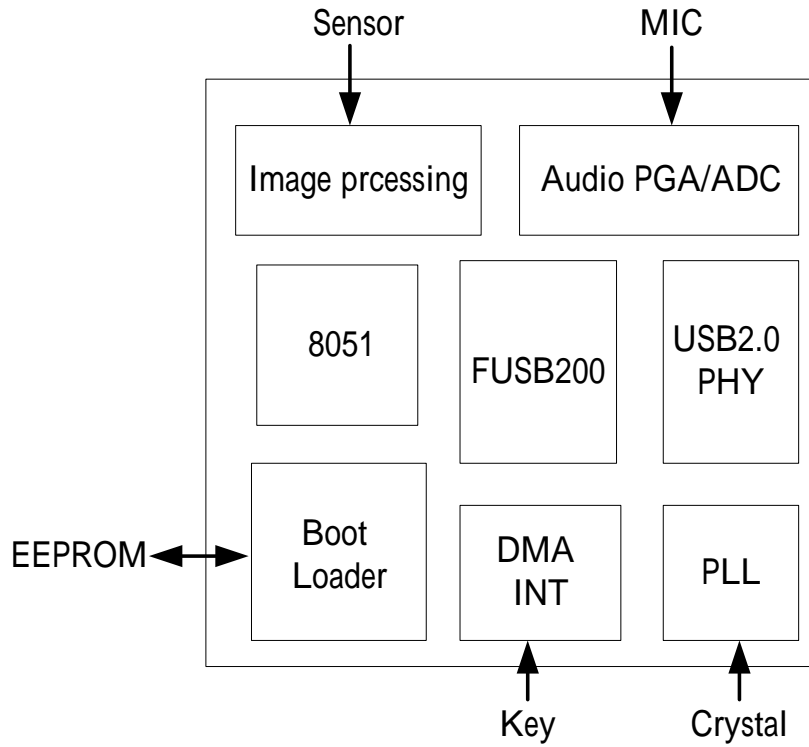

The PAP7501V High-Speed USB2.0 Camera Controller is a highly integrated and cost-effective solution for USB2.0 PC-Camera based applications. It is fully compliant with USB Video Class 1.1 and USB audio class 1.0 standard. It integrates micro-controller, color processor engine, MJPEG encoder, and 24K-byte programmable SRAM.

### 3. Specifications

#### Absolute Maximum Ratings

Exceeding the Absolute Maximum Ratings shown below invalidates all AC and DC electrical specifications and may result in permanent device damage.

Symbol	Parameter	Min	Max	Unit	Notes
T <sub>STG</sub>	Ambient storage temperature	-25	125	°C	
V <sub>DD</sub>	DC supply voltage	-0.5	5.5	V	
V <sub>IN</sub>	DC input voltage	0.5	3.8	V	
V <sub>OUT</sub>	DC output voltage	-0.5	3.8	V	
ESD	ESD Rating, Human Body model		2	kV	

#### Recommend Operating Condition

Symbol	Parameter		Min	Typ.	Max	Unit	Notes
T <sub>A</sub>	Temperature Range	Operation	-10	-	70	°C	
		Stable Image	0	-	50	°C	
V <sub>DD</sub>	Power supply voltage		4.5	5.0	5.5	V	
F <sub>CLK</sub>	System clock frequency		-	12.0	-	MHz	

#### DC Electrical Characteristics (Typical values at 25°C, V<sub>DD</sub>=5.0V, F<sub>CLK</sub>=12.0MHz)

Symbol	Parameter	Min.	Typ.	Max.	Unit	Notes
<b>Type: PWR</b>						
I <sub>DD</sub>	Operating Current	-	70	-	mA	@30 frame/sec
I <sub>PWDN</sub>	Power Down current			500u		
<b>Type: IN &amp; I/O, Reset</b>						
V <sub>IH</sub>	Input voltage HIGH	1.9	-		V	
V <sub>IL</sub>	Input voltage LOW		-	1.3	V	
<b>Type: OUT &amp; I/O</b>						
V <sub>OH</sub>	Output voltage HIGH	0.9 x V <sub>DD33Q</sub>	-	-	V	
V <sub>OL</sub>	Output voltage LOW	-	-	0.1 x V <sub>DD33Q</sub>	V	

4. Packing Information

4.1 Product Ordering Information

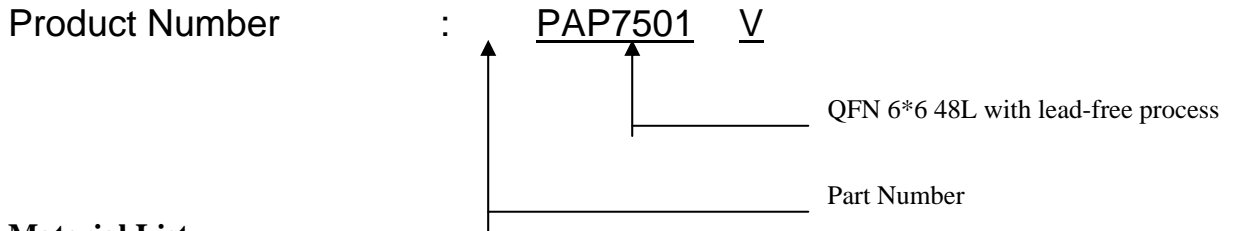

4.2 Material List

Items	Process	Material
1	Leadframe Material	Copper
2	Die Attach	Conductive Epoxy
3	Wire Bonding	4N 1.0 mil Gold Wire
4	Cover	Epoxy Molding Compound
5	Marking	Laser or Ink
6	Lead Finish	Pd/Ni/Au plating

4.3 Package Outline Dimension

Saw Type(A type):

Symbol	Dimension in mm		
	MIN	NOM	MAX
A	0.80	0.85	0.90
A1	0.00	0.2	0.05
A2	0.6	0.65	0.70
A3	0.20 REF		
b	0.15	0.20	0.25
D	6.00 BSC		
E	6.00 BSC		
e	0.40 BSC		
J	4.1	4.3	4.5
K	4.1	4.3	4.5
L	0.3	0.4	0.5

Rev.	Description	Date	Package Type	QFN 6*6 48L
A	New Issue	08/30,06	P_Number	NA
B	Update	12/10,07	Drawn	Fig0 08/30,06
			Check	Chip Size N/A
			Approve	Rev. A

原相科技股份有限公司  
 PixArt Imaging Inc.

Title: QFN 6\*6 Package outline\_saw  
 Part Number: QFN  
 Package Type: QFN 6\*6 48L  
 P\_Number: NA  
 Drawn: Fig0 08/30,06  
 Check: Chip Size N/A  
 Approve: Rev. A

Punch Type(U type):

Symbol	Dimension in mm		
	MIN	NOM	MAX
A	0.80	0.85	0.90
A1	0.00	0.02	0.05
A2	0.60	0.65	0.70
A3	0.20 REF		
b	0.15	0.20	0.25
D/E	6.00 BSC		
D1/E1	5.75 BSC		
D2/E2	4.1	4.3	4.5
e	0.40 BSC		
L	0.30	0.40	0.50
K	0.20	---	---
R	0.075	---	---
Ø	Ø'	---	14'
aaa	---	---	0.15
bbb	---	---	0.10
ccc	---	---	0.10
ddd	---	---	0.05
eee	---	---	0.08
fff	---	---	0.10

NOTE:  
 1. CONTROLLING DIMENSION : MILLIMETER  
 2. REFERENCE DOCUMENT: JEDEC MO-220.

Title		QFN 6*6 Package outline	
Part Number		NA	
Package Type		QFN 6*6 48L	
P_Number		NA	
Drawn		Fig0 02/20,06	Scale
Check		Chip Size N/A	
Approve		Rev. A	

4.4 Pin Assignment

Note: 1) Top view

Title		PAP7501V Pin Assignment	
Part Number		PAP7501V	
Package Type		QFN 6*6 48L	
P_Number		PHP092C	
Drawn		Fig0 09/03,07	Scale
Check		Chip Size NA	
Approve		Rev. A	

4.5 Recommended Layout PCB

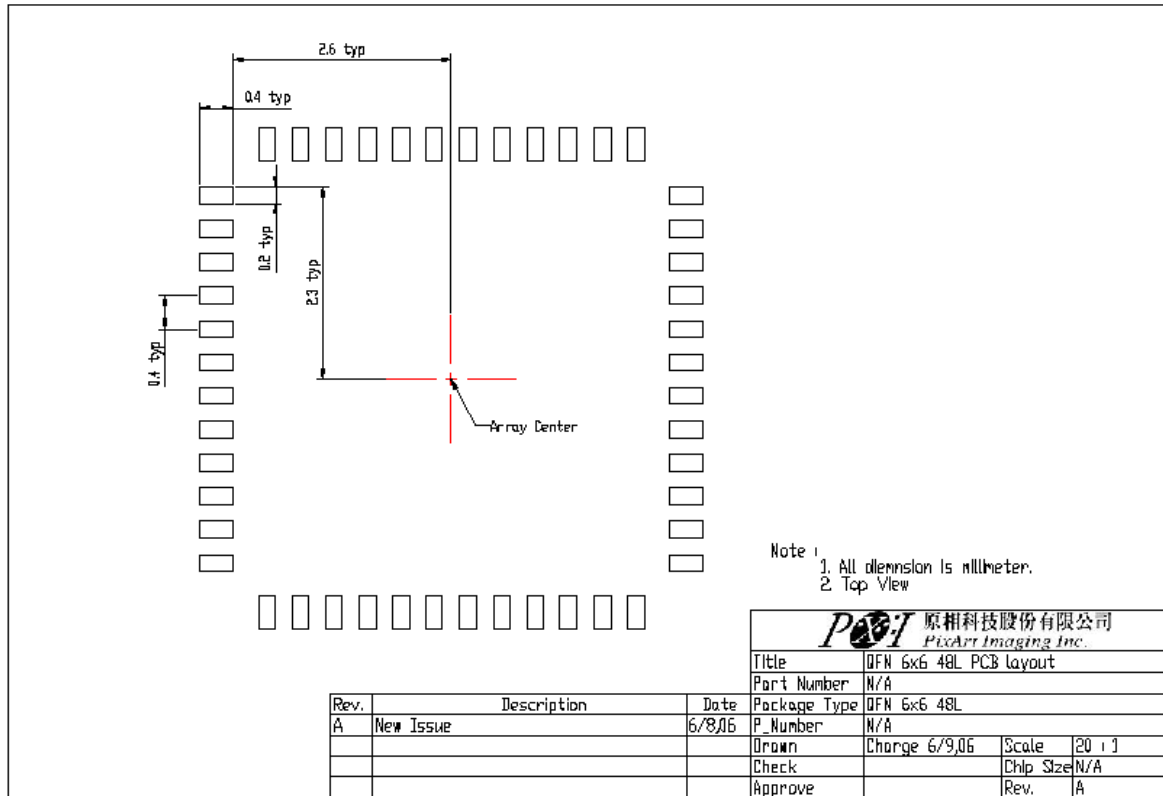

4.6 Packing Information

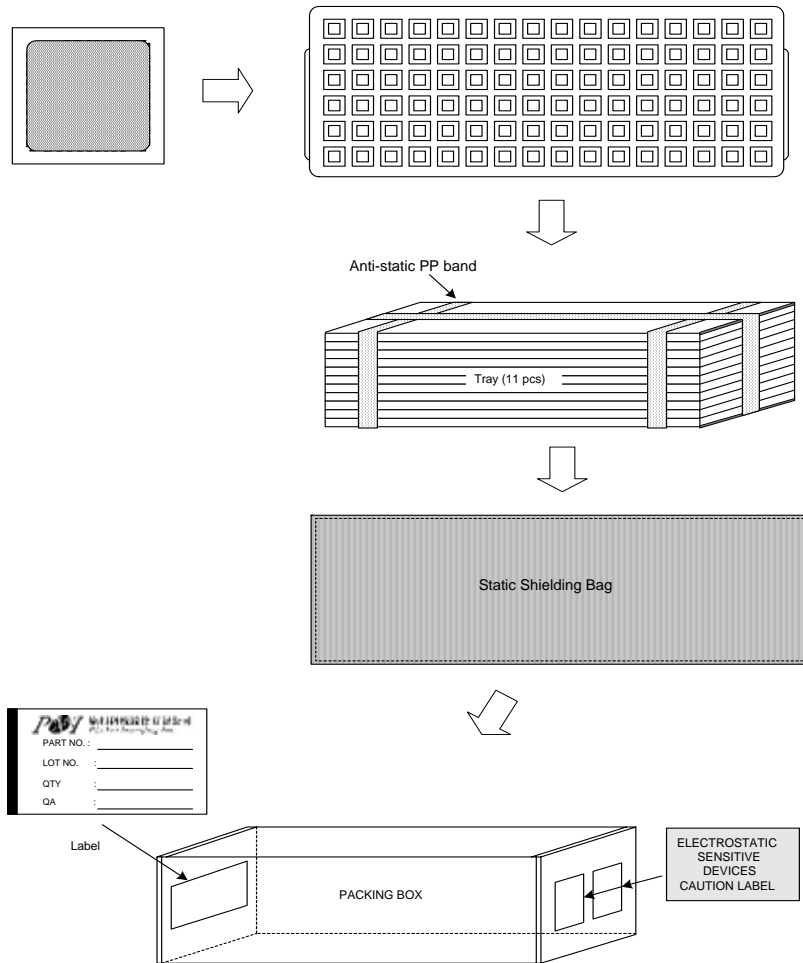

One packing box capacity

One packing box	<b>4900 units</b>
Remark	( 490 units x 10 Trays)

Tray durable temperature = **150**

**Note:** 1. When the units is out of dry packing, should be operation at :

Temperature = 30 , Humidity = 60% RH

2. If units is out of dry packing over 168 hrs, before go through infrared reflow process must be bake with 125 ±5 @24hrs, to remove the moisture.



#### 4.7 Recommended Condition For Infrared Reflow

Carefully observe the mounting conditions, recommended temperature profile when Mounting infrared reflows is show in the figure below.

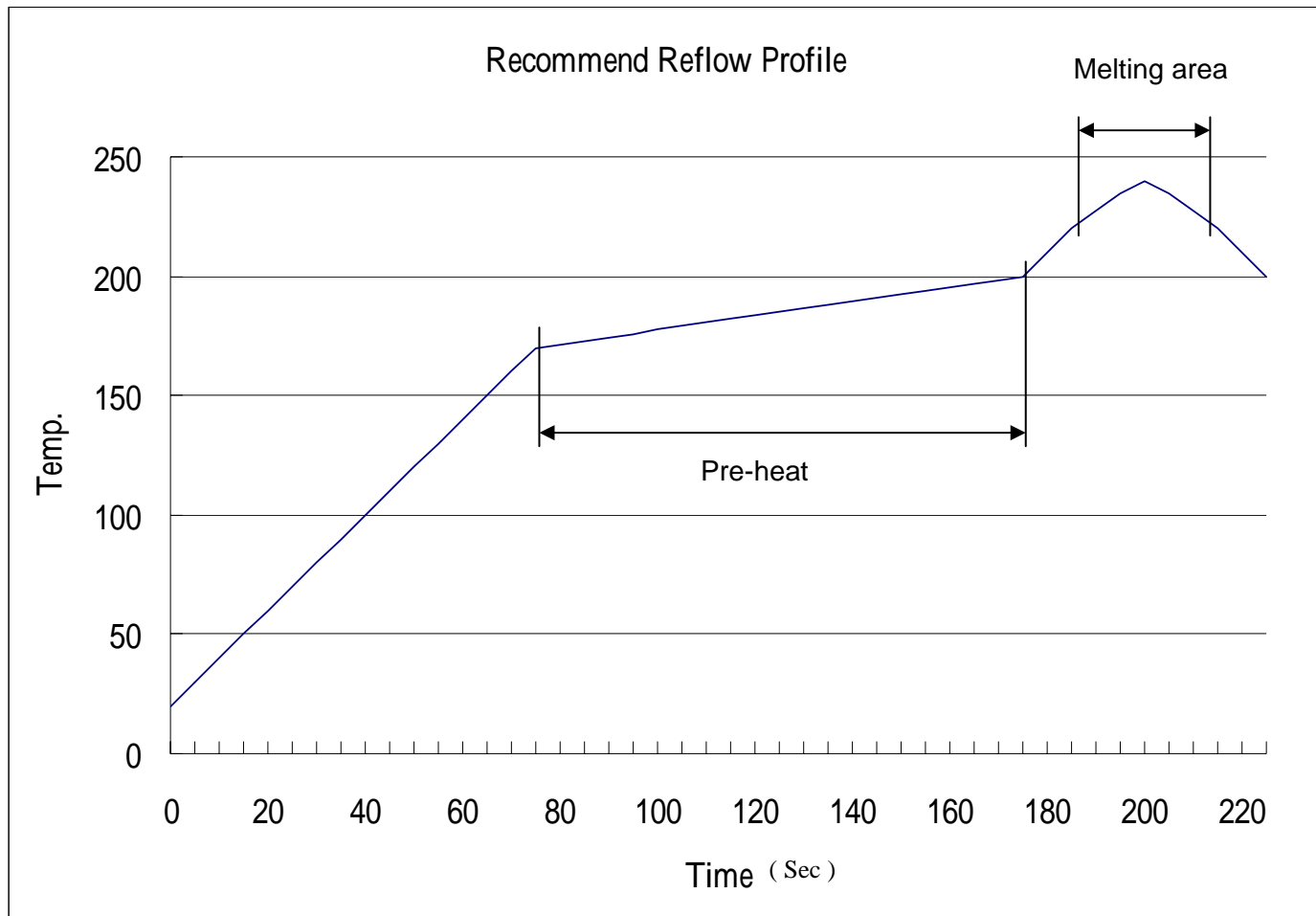

Recommend Pb-free solder paste vender & type : 1. Almit LFM-48W TM-HP  
 2. Senju M705-GRN360-K

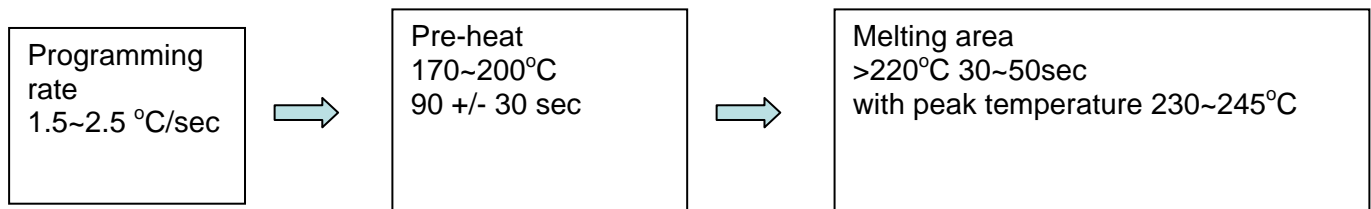

#### **4.8 Handling precaution for the prevention of ESD**

Explained below are procedures that must be taken in fabrication to prevent the electrostatic destruction of semiconductor devices.

The following basic rules must be obeyed.

1. Equalize potentials of terminals when transporting or storing.
2. Equalize the potentials of the electric device, work table, and operator's body that may come in contact with the IC's.
3. Prepare an environment that does not generate static electricity.  
One method is keeping relative humidity in the work room to about 50%.

##### Operator

1. The operator should wear wrist straps.  
(Must maintain electric contact with bare skin)
2. Wear cotton or antistatic-treated materials clothes and gloves.
3. When a conductive mat will be used, must be ware conductive shoes.
4. Do not touch the IC's leads. Touch the body of IC's when holding.

##### Equipment and tools

1. Any electrical equipments and tools located on the work table surface must be isolated from The work table surface, and ground the equipments and tools that are to be used.
2. Work table surface must be use conductive material or conductive mat.  
(Should be ground through a 1M resistor)

##### Transporting, storing and packing

1. Use conductive IC's tray, and conductive or shielding bag to store IC's.

##### Soldering operation

1. Use a soldering iron with a grounding wire.
2. When perform manual soldering operation, the operator should wear wrist straps.
3. Do not use the desoldering pump when removing the IC's from the PCB board. Use a solder-wick or equivalent.

5. Reference Application Circuit  
5.1 PAP7501 with PAS6311

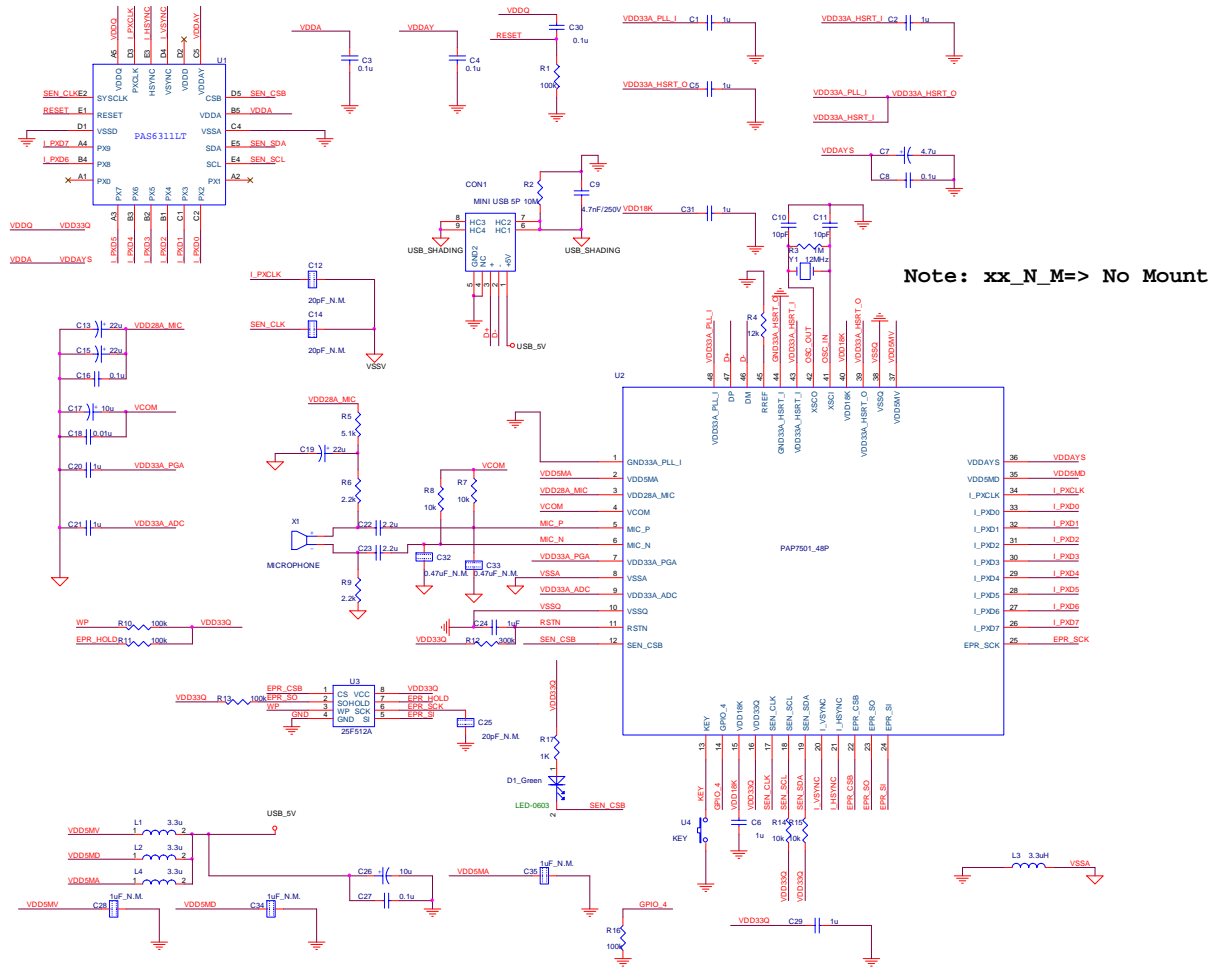

**6. Update History**

<b>Version</b>	<b>Update</b>	<b>Date</b>
V1.0	Creation, Preliminary 1 <sup>st</sup> version	01/17/2008
V1.1	Update circuit and Package information, Add C30~C35, R17, D1, Change R5 to 5.1k ohm, R6 and R9 Change to 2.2k ohm	05/06/2008