

512Mb DDR2 SDRAM

Feature

CAS Latency Frequency

Speed Bins	-3C/3CI*		-AC/ACI*		-BE*		-BD*		Units
	(DDR2-667-CL5)		(DDR2-800-CL5)		(DDR2-1066-CL7)		(DDR2-1066-CL6)		
Parameter	Min.	Max.	Min.	Max.	Min.	Max.	Min.	Max.	tCK _(Avg.)
Clock Frequency	125	333	125	400	125	533	125	533	MHz
tRCD	15	-	12.5	-	12.5	-	11.25	-	ns
tRP	15	-	12.5	-	12.5	-	11.25	-	ns
tRC	60	-	57.5	-	57.5	-	56.25	-	ns
tRAS	40	70K	40	70K	40	70K	40	70K	ns
tCK_(Avg.)@CL3	5	8	5	8	5	8	5	8	ns
tCK_(Avg.)@CL4	3.75	8	3.75	8	3.75	8	3.75	8	ns
tCK_(Avg.)@CL5	3	8	2.5	8	2.5	8	2.5	8	ns
tCK_(Avg.)@CL6	-	-	2.5	8	2.5	8	1.875	8	ns
tCK_(Avg.)@CL7	-	-	-	-	1.875	8	1.875	8	ns

*The timing specification of high speed bin is backward compatible with low speed bin

- 1.8V ± 0.1V Power Supply Voltage
- 4 internal memory banks
- Programmable CAS Latency:
 - 3, 4, 5 (-3C/-3CI/-AC/-ACI/-BD/-BE)
 - 6 (-AC/-ACI/-BD/-BE)
 - 7 (-BD/-BE)
- Programmable Additive Latency: 0, 1, 2, 3, 4 5
- Write Latency = Read Latency -1
- Programmable Burst Length:
 - 4 and 8 Programmable Sequential / Interleave Burst
- OCD (Off-Chip Driver Impedance Adjustment)
- ODT (On-Die Termination)
- 4 bit prefetch architecture
- Data-Strobes: Bidirectional, Differential
- Support Industrial grade temperature -40°C ~95°C
Operating Temperature (-3CI/-ACI)
- 1KB page size for x8
- 2KB page size for x16
- Strong and Weak Strength Data-Output Driver
- Auto-Refresh and Self-Refresh
- Power Saving Power-Down modes
- 7.8 μs max. Average Periodic Refresh Interval
- RoHS Compliance and Halogen Free
- Packages:
 - 60-Ball BGA for x8 components
 - 84-Ball BGA for x16 components

512Mb DDR2 SDRAM

Description

The 512Mbit Double-Data-Rate-2 (DDR2) DRAMs is a high-speed CMOS Double Data Rate 2 SDRAM containing 536,870,912 bits. It is internally configured as a quad-bank DRAM.

The 512Mb chip is organized as 16Mbit x 8 I/O x 4 bank or 8Mbit x 16 I/O x 4 bank device. These synchronous devices achieve high speed double-data-rate transfer rates of up to 1066 Mb/sec/pin for general applications.

The chip is designed to comply with all key DDR2 DRAM key features: (1) posted CAS with additive latency, (2) write latency = read latency -1, (3) normal and weak strength data-output driver, (4) variable data-output impedance adjustment and (5) an ODT (On-Die Termination) function.

All of the control and address inputs are synchronized with a pair of externally supplied differential clocks. Inputs are latched at the cross point of differential clocks (CK rising and \overline{CK} falling). All I/Os are synchronized with a single ended DQS or differential DQS pair in a source synchronous fashion. A 14 bit address bus for x8 organized components and A 13 bit address bus for x16 component is used to convey row, column, and bank address devices.

These devices operate with a single $1.8V \pm 0.1V$ power supply and are available in BGA packages.

512Mb DDR2 SDRAM

Pin Configuration – 60 balls BGA Package (x8)

< TOP View >

See the balls through the package

X 8						
1	2	3		7	8	9
VDD	NU,/RDQS	VSS	A	VSSQ	DQS	VDDQ
DQ6	VSSQ	DM/RDQS	B	DQS	VSSQ	DQ7
VDDQ	DQ1	VDDQ	C	VDDQ	DQ0	VDDQ
DQ4	VSSQ	DQ3	D	DQ2	VSSQ	DQ5
VDDL	VREF	VSS	E	VSSDL	CK	VDD
	CKE	WE	F	RAS	CK	ODT
NC	BA0	BA 1	G	CAS	CS	
	A10/ AP	A1	H	A2	A0	VDD
VSS	A3	A5	J	A6	A4	
	A7	A9	K	A11	A8	VSS
VDD	A12	NC	L	NC	A13	

512Mb DDR2 SDRAM

Pin Configuration – 84 balls BGA Package (x16)

< TOP View >

See the balls through the package

x 16						
1	2	3		7	8	9
VDD	NC	VSS	A	VSSQ	\overline{UDQS}	VDDQ
DQ14	VSSQ	UDM	B	UDQS	VSSQ	DQ15
VDDQ	DQ9	VDDQ	C	VDDQ	DQ8	VDDQ
DQ12	VSSQ	DQ11	D	DQ10	VSSQ	DQ13
VDD	NC	VSS	E	VSSQ	\overline{LDQS}	VDDQ
DQ6	VSSQ	LDM	F	LDQS	VSSQ	DQ7
VDDQ	DQ1	VDDQ	G	VDDQ	DQ0	VDDQ
DQ4	VSSQ	DQ3	H	DQ2	VSSQ	DQ5
VDDL	VREF	VSS	J	VSSDL	\overline{CK}	VDD
	CKE	\overline{WE}	K	\overline{RAS}	\overline{CS}	ODT
NC	BA0	BA 1	L	\overline{CAS}		
	A10/ AP	A1	M	A2	A0	VDD
VSS	A3	A5	N	A6	A4	
	A7	A9	P	A11	A8	VSS
VDD	A12	NC	R	NC	NC	

512Mb DDR2 SDRAM

Input / Output Functional Description

Symbol	Type	Function
CK, \overline{CK}	Input	Clock: CK and \overline{CK} are differential clock inputs. All address and control input signals are sampled on the crossing of the positive edge of CK and negative edge of \overline{CK} . Output (read) data is referenced to the crossings of CK and \overline{CK} (both directions of crossing).
CKE	Input	Clock Enable: CKE high activates, and CKE low deactivates, internal clock signals and device input buffers and output drivers. Taking CKE low provides Precharge Power-Down and Self-Refresh operation (all banks idle), or Active Power-Down (row Active in any bank). CKE is synchronous for power down entry and exit and for Self-Refresh entry. CKE is asynchronous for Self-Refresh exit. After VREF has become stable during the power on and initialization sequence, it must be maintained for proper operation of the CKE receiver. For proper self-refresh entry and exit, VREF must maintain to this input. CKE must be maintained high throughout read and write accesses. Input buffers, excluding CK, \overline{CK} , ODT and CKE are disabled during Power Down. Input buffers, excluding CKE, are disabled during Self-Refresh.
\overline{CS}	Input	Chip Select: All commands are masked when \overline{CS} is registered high. \overline{CS} provides for external rank selection on systems with multiple memory ranks. \overline{CS} is considered part of the command code.
\overline{RAS} , \overline{CAS} , \overline{WE}	Input	Command Inputs: \overline{RAS} , \overline{CAS} and \overline{WE} (along with \overline{CS}) define the command being entered.
DM, LDM, UDM	Input	Input Data Mask: DM is an input mask signal for write data. Input data is masked when DM is sampled high coincident with that input data during a Write access. DM is sampled on both edges of DQS. Although DM pins are input only, the DM loading matches the DQ and DQS loading. For x8 device, the function of DM or RDQS / \overline{RDQS} is enabled by EMRS command.
BA0 – BA1	Input	Bank Address Inputs: BA0 and BA1 define to which bank an Active, Read, Write or Precharge command is being applied. Bank address also determines if the mode register or extended mode register is to be accessed during a MRS or EMRS cycle.
A0 – A13	Input	Address Inputs: Provides the row address for Activate commands and the column address and Auto Precharge or Read/Write commands to select one location out of the memory array in the respective bank. A10 is sampled during a Precharge command to determine whether the precharge applies to one bank (A10=low) or all banks (A10=high). If only one bank is to be precharged, the bank is selected by BA0-BA1. The address inputs also provide the op-code during Mode Register Set commands. A13 Row address use on x8 components only.
DQ	Input/output	Data Inputs/Output: Bi-directional data bus.
DQS, (\overline{DQS}) LDQS, (\overline{LDQS}), UDQS, (\overline{UDQS})	Input/output	Data Strobe: output with read data, input with write data. Edge aligned with read data, centered with write data. For the x16, LDQS corresponds to the data on DQ0 - DQ7; UDQS corresponds to the data on DQ8-DQ15. The data strobes DQS, LDQS, UDQS, and RDQS may be used in single ended mode or paired with the optional complementary signals \overline{DQS} , \overline{LDQS} , \overline{UDQS} to provide differential pair signaling to the system during both reads and writes. An EMRS(1) control bit enables or disables the complementary data strobe signals.

512Mb DDR2 SDRAM

Symbol	Type	Function
RDQS, ($\overline{\text{RDQS}}$)	Input/output	Read Data Strobe: For x8 components a RDQS and $\overline{\text{RDQS}}$ pair can be enabled via EMRS(1) for real timing. RDQS and $\overline{\text{RDQS}}$ is not support x16 components. RDQS and $\overline{\text{RDQS}}$ are edge-aligned with real data. If enable RDQS and $\overline{\text{RDQS}}$ then DM function will be disabled.
ODT	Input	On Die Termination: ODT (registered HIGH) enables termination resistance internal to the DDR2 SDRAM. When enabled, ODT is applied to each DQ, DQS, $\overline{\text{DQS}}$, RDQS, $\overline{\text{RDQS}}$, and DM signal for x8 configuration. For x16 configuration ODT is applied to each DQ, UDQS, $\overline{\text{UDQS}}$, LDQS, $\overline{\text{LDQS}}$, UDM and LDM signal. The ODT pin will be ignored if the EMRS (1) is programmed to disable ODT.
NC		No Connect: No internal electrical connection is present.
VDDQ	Supply	DQ Power Supply: 1.8V \pm 0.1V
VSSQ	Supply	DQ Ground
VDDL	Supply	DLL Power Supply: 1.8V \pm 0.1V
VSSDL	Supply	DLL Ground
VDD	Supply	Power Supply: 1.8V \pm 0.1V
VSS	Supply	Ground
VREF	Supply	SSTL_1.8 reference voltage

Ordering Information

Green

Standard Grade				
Organization	Part Number	Package	Speed	
			Clock (MHz)	CL-T _{RCD} -T _{RP}
		NT5TU64M8DE-3C	60-Ball BGA	333
	NT5TU64M8DE-AC	400		5-5-5
	NT5TU32M16DG-3C	84-Ball BGA	333	5-5-5
	NT5TU32M16DG-AC		400	5-5-5
	NT5TU32M16DG-BD		533	6-6-6
	NT5TU32M16DG-BE		533	7-7-7
Industrial Grade				
Organization	Part Number	Package	Speed	
			Clock (MHz)	CL-T _{RCD} -T _{RP}
		NT5TU64M8DE-3CI	60-Ball BGA	333
	NT5TU64M8DE-ACI	400		5-5-5
	NT5TU32M16DG-3CI	84-Ball BGA	333	5-5-5
	NT5TU32M16DG-ACI		400	5-5-5

512Mb DDR2 SDRAM

Block Diagram (64Mb x 8)

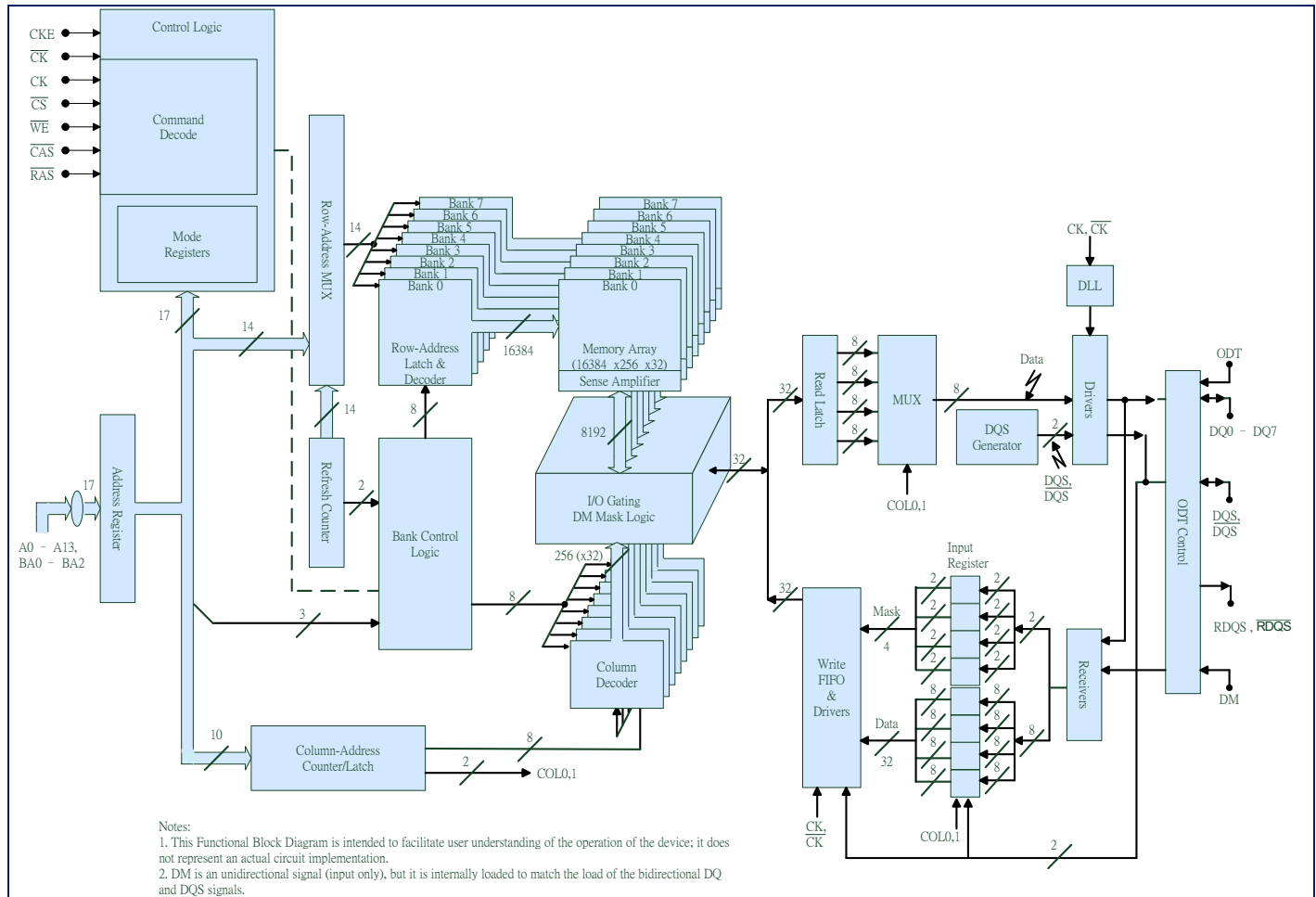

512Mb DDR2 SDRAM

Block Diagram (32Mb x 16)

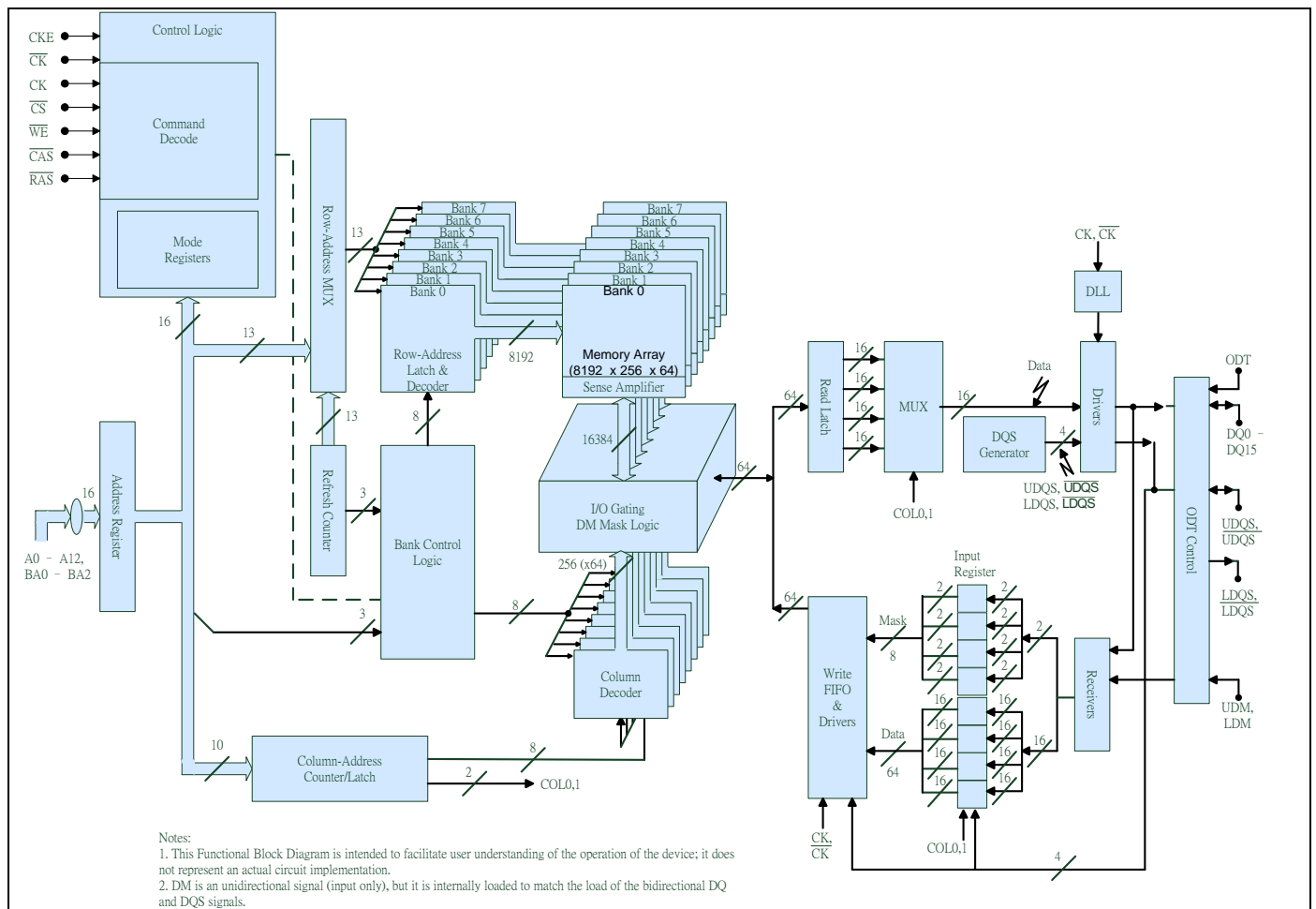

512Mb DDR2 SDRAM

Functional Description

The 512Mb DDR2 SDRAM is a high-speed CMOS, dynamic random-access memory containing 536,870,912 bits. The 512Mb DDR2 SDRAM is internally configured as a quad-bank DRAM.

Read and write accesses to the DDR2 SDRAM are burst oriented; accesses start at a selected location and continue for the burst length of four or eight in a programmed sequence. Accesses begin with the registration of an Activate command, which is followed by a Read or Write command. The address bits registered coincident with the activate command are used to select the bank and row to be accesses (BA0 and BA1 select the banks, A0-A13 select the row for x8 components, A0-A12 select the row for x16 components). The address bits registered coincident with the Read or Write command are used to select the starting column location for the burst access and to determine if the Auto-Precharge command is to be issued.

Prior to normal operation, the DDR2 SDRAM must be initialized. The following sections provide detailed information covering device initialization, register definition, command description and device operation.

Power-up and Initialization

DDR2 SDRAMs must be powered up and initialized in a predefined manner. Operational procedures other than those specified may result in undefined operation.

The following sequence is required for POWER UP and Initialization.

1. Either one of the following sequence is required for Power-up.

While applying power, attempt to maintain CKE below $0.2 \times VDDQ$ and ODT at a Low state (all other inputs may be undefined) The VDD voltage ramp time must be no greater than 200ms from when VDD ramps from 300mV to VDD min; and during the VDD voltage ramp up, $|VDD - VDDQ| \leq 0.3$ volts. Once the ramping of the supply voltages is complete (when VDDQ crosses VDDQ min), the supply voltage specifications in Re-commanded DC operating conditions table.

- VDD, VDDL, and VDDQ are driven from a signal power converter output, AND
- VTT is limited to 0.95V max, AND
- Vref tracks $VDDQ/2$; Vref must be within ± 300 mV with respect to $VDDQ/2$ during supply ramp time.
- $VDDQ \geq VREF$ must be met at all times.

While applying power, attempt to maintain CKE below $0.2 \times VDDQ$ and ODT at a Low state, all other inputs may be undefined, voltage levels at I/Os and outputs must be less than VDDQ during voltage ramp time to avoid DRAM latch-up. During the ramping of the supply voltages, $VDD \geq VDDL \geq VDDQ$ must be maintained and is applicable to both AC and DC levels until the ramping of the supply voltages is complete, which is when VDDQ crosses VDDQ min. Once the ramping of the supply voltages is complete, the supply voltage specifications provided in Re-commanded DC operating conditions table.

- Apply VDD/VDDL before or at the same time as VDDQ.
- VDD/VDDL voltage ramp time must be no greater than 200ms from when VDD ramps from 300mV to VDDmin.
- Apply VDDQ before or at the same time as VTT.

512Mb DDR2 SDRAM

- The VDDQ voltage ramp time from when VDD min is achieved on VDD to when VDDQ min is achieved on VDDQ must be no greater than 500ms. (Note: While VDD is ramping, current may be supplied from VDD through the DRAM to VDDQ.)

- Vref must track VDDQ/2; Vref must be within ±300mV with respect to VDDQ/2 during supply ramp time.

- VDDQ ≥ VREF must be met at all time.

- Apply VTT.

2. Start clock (CK, \overline{CK}) and maintain stable condition.

3. For the minimum of 200us after stable power (VDD, VDDL, VDDQ, VREF, and VTT are between their minimum and maximum values as stated in Re-commanded DC operating conditions table, and stable clock, then apply NOP or Deselect & take CKE HIGH.

4. Waiting minimum of 400ns then issue pre-charge all command. NOP or Deselect applied during 400ns period.

5. Issue an EMRS command to EMR (2). (Provide LOW to BA0, and HIGH to BA1).

6. Issue an EMRS command to EMR (3). (HIGH to BA0 and BA1).

7. Issue EMRS to enable DLL. (Provide Low to A0, HIGH to BA0 and LOW to BA1 and A13. And A9=A8=A7=LOW must be used when issuing this command.)

8. Issue a Mode Register Set command for DLL reset. (Provide HIGH to A8 and LOW to BA0 and A13)

9. Issue a precharge all command.

10. Issue 2 more auto-refresh commands.

11. Issue a MRS command with LOW to A8 to initialize device operation (i.e. to program operating parameters without resetting the DLL.)

12. At least 200 clocks after step 7, execute OCD Calibration (Off Chip Driver impedance adjustment). If OCD calibration is not used, EMRs to EMR (1) to set OCD Calibration Default (A9=A8=A7=HIGH) followed by EMRS to EMR (1) to exit OCD Calibration Mode (A9=A8=A7=LOW) must be issued with other operating parameters of EMR(1).

13. The DDR2 DRAM is now ready for normal operation.

* To guarantee ODT off, VREF must be valid and a low level must be applied to the ODT pin.

Example:

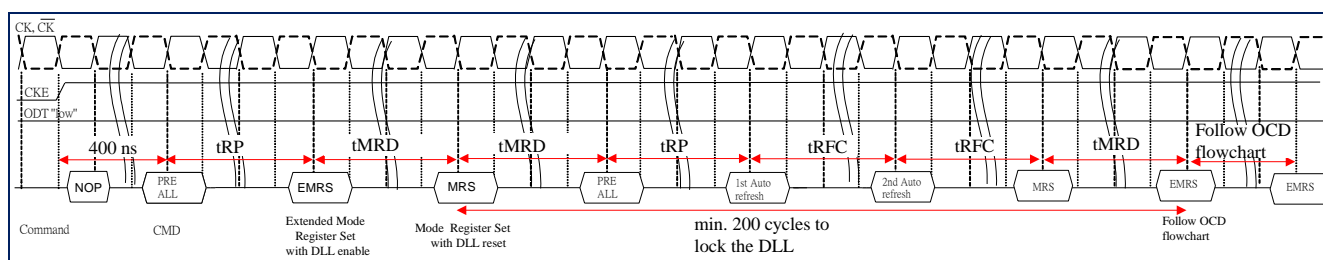

512Mb DDR2 SDRAM

Register Definition

Programming the Mode Registration and Extended Mode Registers

For application flexibility, burst length, burst type, $\overline{\text{CAS}}$ latency, DLL reset function, write recovery time (t_{WR}) are user defined variables and must be programmed with a Mode Register Set (MRS) command. Additionally, DLL disable function, additive $\overline{\text{CAS}}$ latency, driver impedance, ODT (On Die Termination), single-ended strobe and OCD (off chip driver impedance adjustment) are also user defined variables and must be programmed with an Extended Mode Register Set (EMRS) command. Contents of the Mode Register (MR) and Extended Mode Registers (EMR (#)) can be altered by re-executing the MRS and EMRS Commands. If the user chooses to modify only a subset of the MRS or EMRS variables, all variables must be redefined when the MRS or EMRS commands are issued. MRS, EMRS and DLL Reset do not affect array contents, which mean re-initialization including those can be executed any time after power-up without affecting array contents.

Mode Registration Set (MRS)

The mode register stores the data for controlling the various operating modes of DDR2 SDRAM. It controls $\overline{\text{CAS}}$ latency, burst length, burst sequence, test mode, DLL reset, t_{WR} and various vendor specific options to make DDR2 SDRAM useful for various applications. The default value of the mode register is not defined, therefore the mode register must be written after power-up for proper operation. The mode register is written by asserting low on $\overline{\text{CS}}$, $\overline{\text{RAS}}$, $\overline{\text{CAS}}$, $\overline{\text{WE}}$, BA0 and BA1, while controlling the state of address pins A0 ~ A13. The DDR2 SDRAM should be in all banks precharged (idle) mode with CKE already high prior to writing into the mode register. The mode register set command cycle time (t_{MRD}) is required to complete the write operation to the mode register. The mode register contents can be changed using the same command and clock cycle requirements during normal operation as long as all banks are in the precharged state. The mode register is divided into various fields depending on functionality. Burst length is defined by A0 ~ A2 with options of 4 and 8 bit burst length. Burst address sequence type is defined by A3 and $\overline{\text{CAS}}$ latency is defined by A4 ~ A6. A7 is used for test mode and must be set to low for normal MRS operation. A8 is used for DLL reset. A9 ~ A11 are used for write recovery time (WR) definition for Auto-Precharge mode.

512Mb DDR2 SDRAM

MRS Mode Register Operation Table (Address Input for Mode Set)

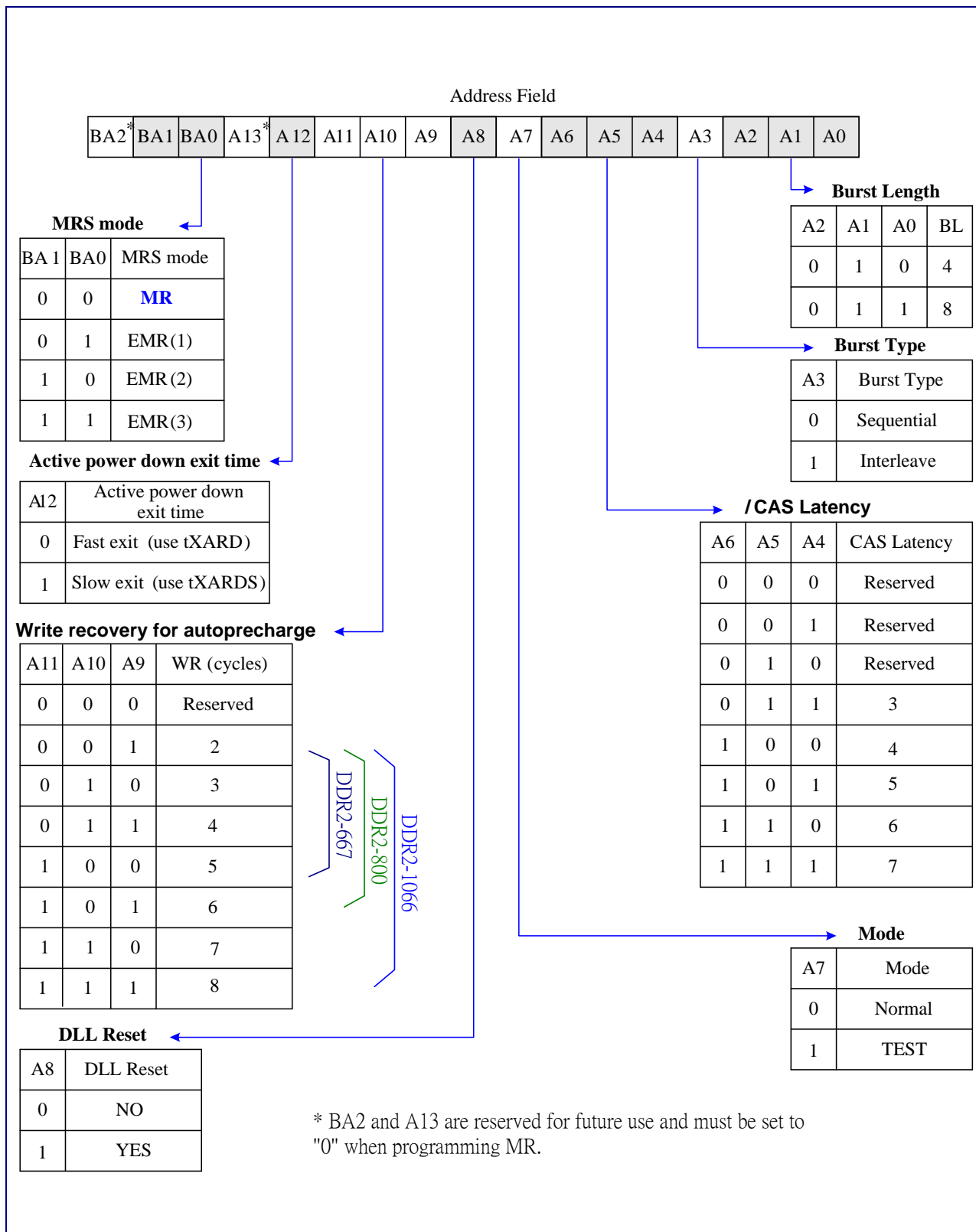

512Mb DDR2 SDRAM

Extended Mode Register Set -EMRS (1) Programming

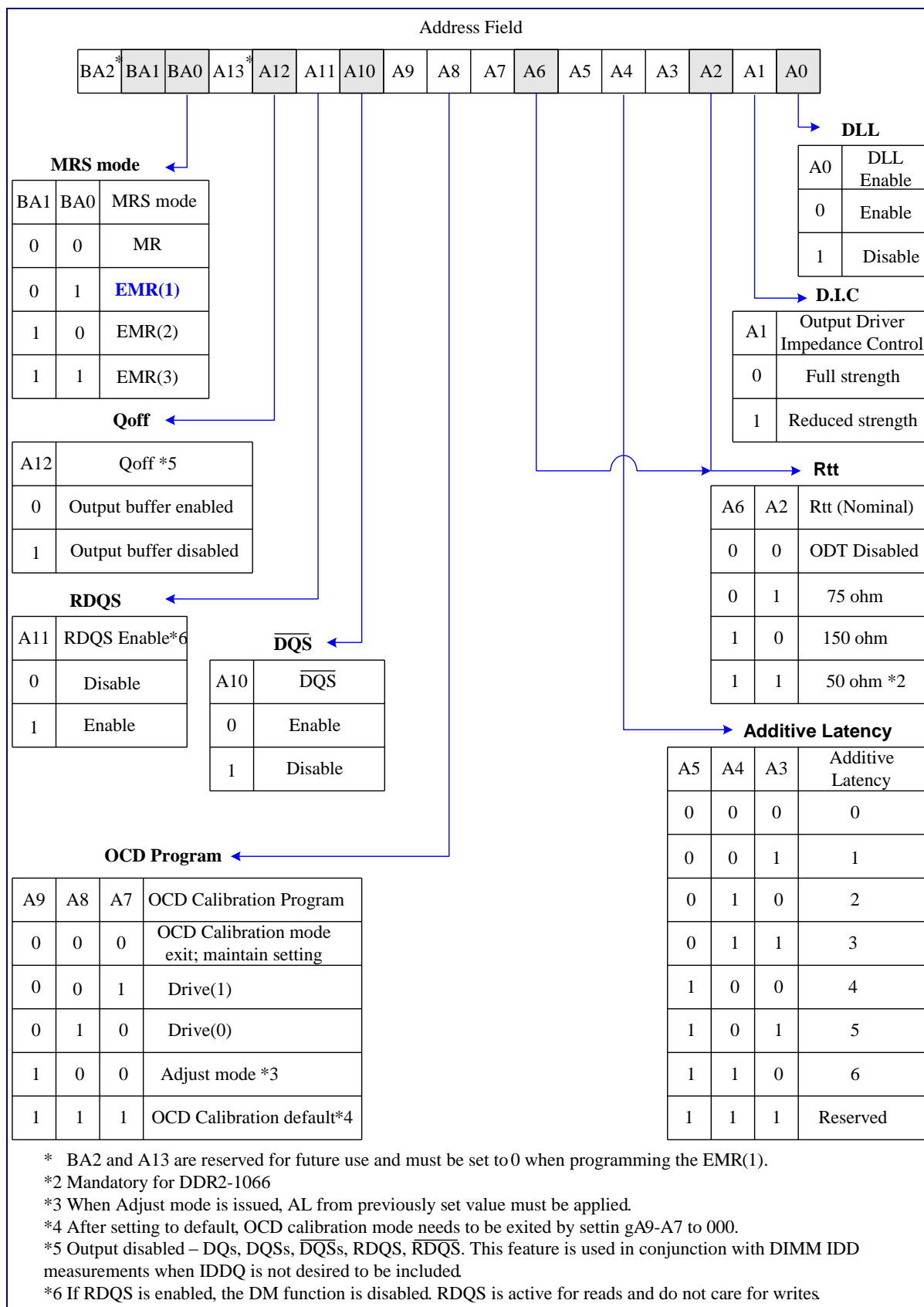

512Mb DDR2 SDRAM

Extended Mode Register Set –EMRS (1)

The extended mode register EMRS(1) stores the data for enabling or disabling the DLL, output driver strength, additive latency, ODT, \overline{DQS} disable, OCD program, RDQS enable. The default value of the extended mode register EMRS(1) is not defined, therefore the extended mode register must be written after power-up for proper operation. The extended mode register is written by asserting low on \overline{CS} , \overline{RAS} , \overline{CAS} , \overline{WE} , BA1 and high on BA0, while controlling the state of the address pins. The DDR2 SDRAM should be in all bank precharge with CKE already high prior to writing into the extended mode register. The mode register set command cycle time (t_{MRD}) must be satisfied to complete the write operation to the EMRS (1). Mode register contents can be changed using the same command and clock cycle requirements during normal operation as long as all banks are in precharge state. A0 is used for DLL enable or disable. A1 is used for enabling a half strength output driver. A3-A5 determines the additive latency, A7-A9 are used for OCD control, A10 is used for \overline{DQS} disable and A11 is used for RDQS enable. A2 and A6 are used for ODT setting.

Single-ended and Differential Data Strobe Signals

The following table lists all possible combinations for DQS, \overline{DQS} , RDQS, \overline{RDQS} which can be programmed by A10 & A11 address bits in EMRS(1). RDQS and \overline{RDQS} are available in x8 components only. If RDQS is enabled in x8 components, the DM function is disabled. RDQS is active for reads and don't care for writes.

EMRS (1)		Strobe Function Matrix				
A11 (RDQS Enable)	A10 (\overline{DQS} Enable)	RDQS/DM	\overline{RDQS}	DQS	\overline{DQS}	Signaling
0 (Disable)	0 (Enable)	DM	Hi-Z	DQS	\overline{DQS}	differential DQS signals
0 (Disable)	1 (Disable)	DM	Hi-Z	DQS	Hi-Z	single-ended DQS signals
1 (Enable)	0 (Enable)	RDQS	\overline{RDQS}	DQS	\overline{DQS}	differential DQS signals
1 (Enable)	1 (Disable)	RDQS	Hi-Z	DQS	Hi-Z	single-ended DQS signals

DLL Enable/Disable

The DLL must be enabled for normal operation. DLL enable is required during power up initialization, and upon returning to normal operation after having the DLL disabled. The DLL is automatically disabled when entering Self-Refresh operation and is automatically re-enabled and reset upon exit of Self-Refresh operation. Any time the DLL is reset, 200 clock cycles must occur before a Read command can be issued to allow time for the internal clock to be synchronized with the external clock. Less clock cycles may result in a violation of the t_{AC} or t_{DQCK} parameters.

Output Disable (Qoff)

Under normal operation, the DRAM outputs are enabled during Read operation for driving data (Q_{off} bit in the EMRS (1) is set to 0). When the Q_{off} bit is set to 1, the DRAM outputs will be disabled. Disabling the DRAM outputs allows users to measure I_{DD} currents during Read operations, without including the output buffer current and external load currents.

512Mb DDR2 SDRAM

EMRS (2) Extended Mode Register Set Programming

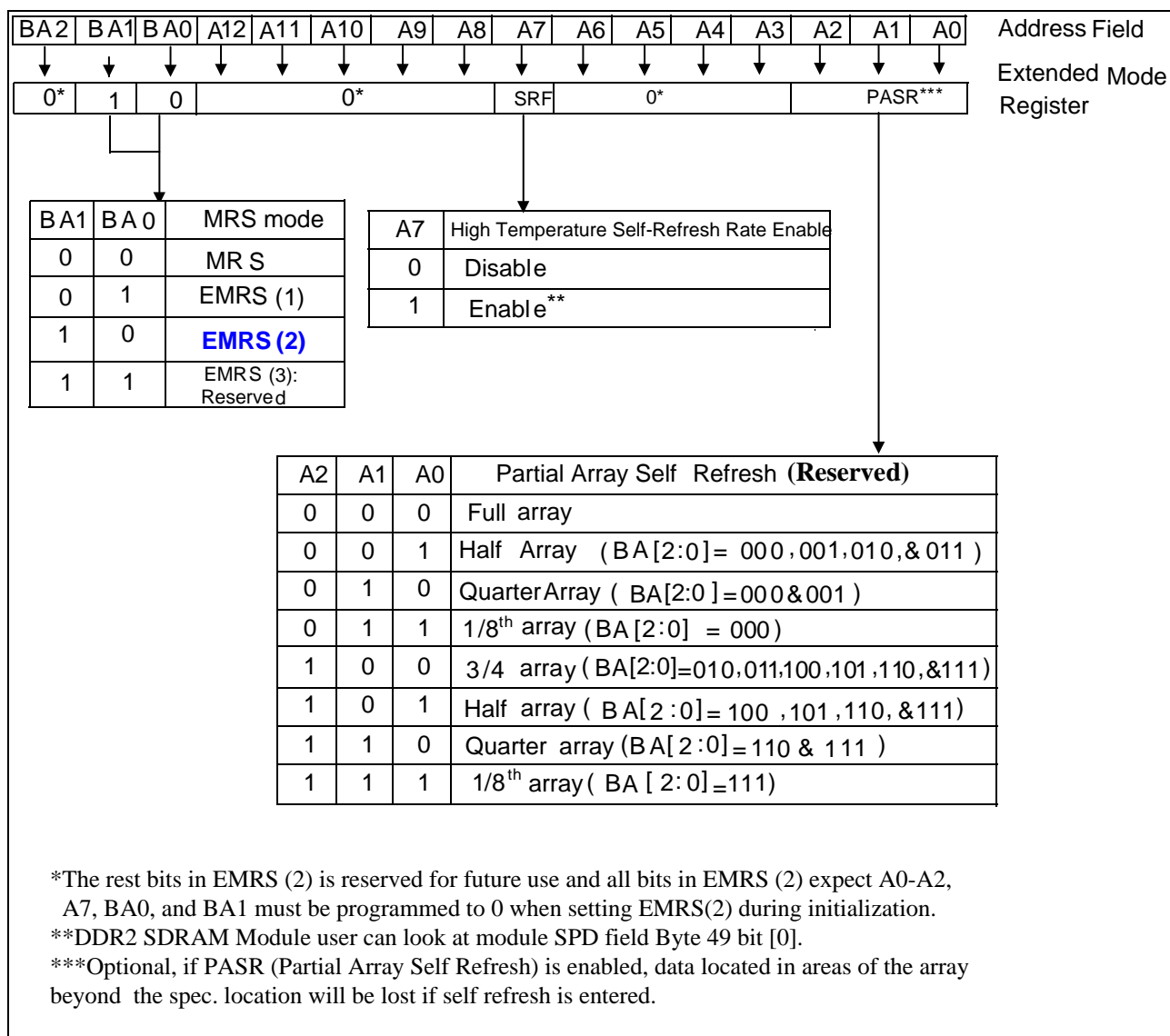

Extended Mode Register Set EMRS (2)

The Extended Mode Registers (2) controls refresh related features. The default value of the extended mode register(2) is not defined, therefore the extended mode register(2) is written by asserting low on CS, RAS, CAS, WE, BA0, high on BA1, while controlling the states of address pin A0-A13. The DDR2 SDRAM should be in all bank precharge with CKE already high prior to writing into the extended mode register (2). The mode register set command cycle time (tMRD) must be satisfied to complete the write operation to the extended mode register (2). Mode register contents can be changed using the same command and clock cycle requirements during normal operation as long as all banks are in the precharge state.

EMRS(3) Extended Mode Register Set Programming

All bits in EMRS(3) except BA0 and BA1 are reserved for future use and must be programmed to 0 when setting the mode register during initialization.

512Mb DDR2 SDRAM

Off-Chip Driver (OCD) Impedance Adjustment

DDR2 SDRAM supports driver calibration feature and the flow chart below is an example of the sequence. Every calibration mode command should be followed by "OCD calibration mode exit" before any other command being issued. MRS should be set before entering OCD impedance adjustment and ODT (On Die Termination) should be carefully controlled depending on system environment.

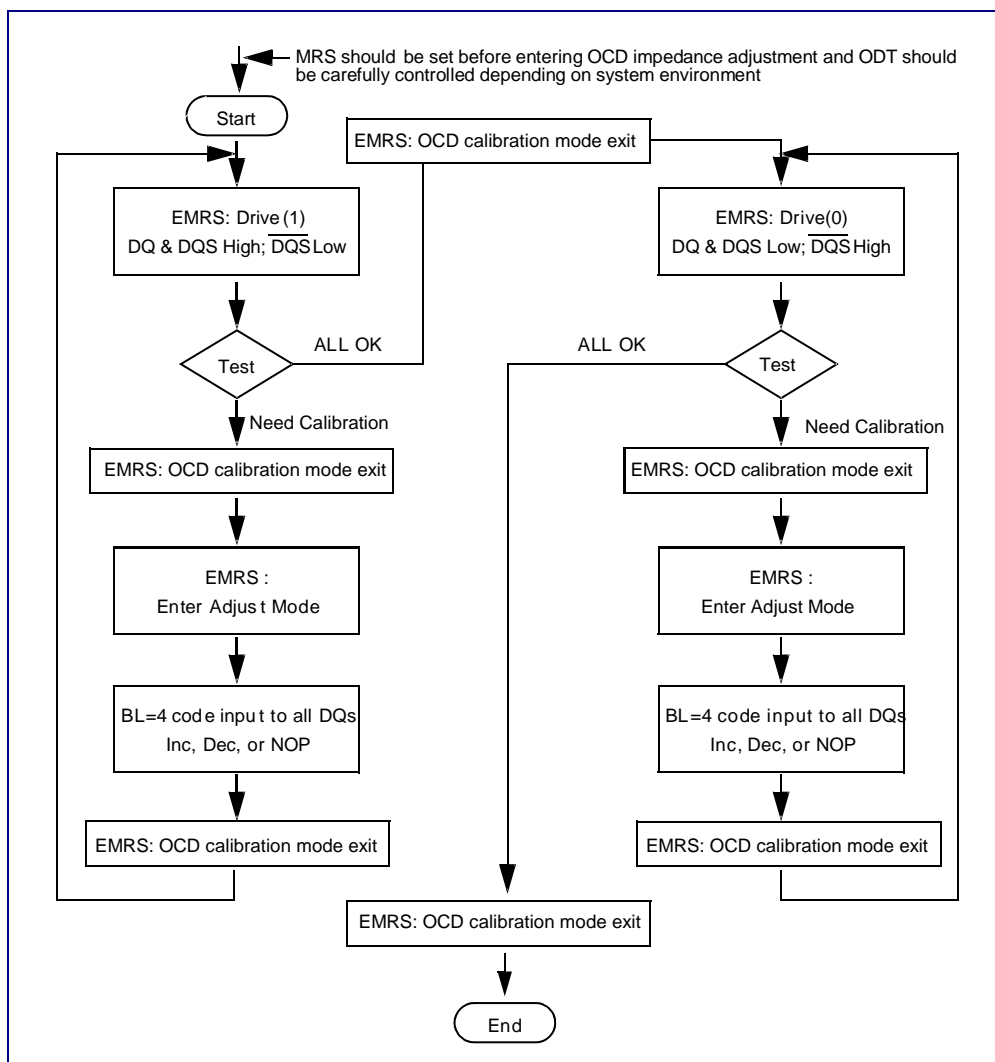

512Mb DDR2 SDRAM

Extended Mode Register Set for OCD impedance adjustment

OCD impedance adjustment can be done using the following EMRS (1) mode. In drive mode all outputs are driven out by DDR2 SDRAM and drive of RDQS is dependent on EMRS (1) bit enabling RDQS operation. In Drive (1) mode, all DQ, DQS (and RDQS) signals are driven high and all \overline{DQS} (and \overline{RDQS}) signals are driven low. In Drive (0) mode, all DQ, DQS (and RDQS) signals are driven low and all \overline{DQS} (and \overline{RDQS}) signals are driven high. In adjust mode, BL = 4 of operation code data must be used. In case of OCD calibration default, output driver characteristics have a nominal impedance value of 18 Ohms during nominal temperature and voltage conditions. Output driver characteristics for OCD calibration default are specified in the following table. OCD applies only to normal full strength output drive setting defined by EMRS (1) and if half strength is set, OCD default driver characteristics are not applicable. When OCD calibration adjust mode is used, OCD default output driver characteristics are not applicable. After OCD calibration is completed or driver strength is set to default, subsequent EMRS(1) commands not intended to adjust OCD characteristics must specify A7~A9 as '000' in order to maintain the default or calibrated value.

Off- Chip-Driver program

A9	A8	A7	Operation
0	0	0	OCD calibration mode exit
0	0	1	Drive(1) DQ, DQS, (RDQS) high and \overline{DQS} low
0	1	0	Drive(0) DQ, DQS, (RDQS) low and \overline{DQS} high
1	0	0	Adjust mode
1	1	1	OCD calibration default

512Mb DDR2 SDRAM

OCD impedance adjust

To adjust output driver impedance, controllers must issue the ADJUST EMRS (1) command along with a 4 bit burst code to DDR2 SDRAM as in the following table. For this operation, Burst Length has to be set to BL = 4 via MRS command before activating OCD and controllers must drive the burst code to all DQs at the same time. DT0 is the table means all DQ bits at bit time 0, DT1 at bit time 1, and so forth. The driver output impedance is adjusted for all DDR2 SDRAM DQs simultaneously and after OCD calibration, all DQs of a given DDR2 SDRAM will be adjusted to the same driver strength setting. The maximum step count for adjustment can be up to 16 and when the limit is reached, further increment or decrement code has no effect. The default setting may be any step within the maximum step count range. When Adjust mode command is issued, AL from previously set value must be applied.

4 bit burst code inputs to all DQs				Operation	
DT0	DT1	DT2	DT3	Pull-up driver strength	Pull-down driver strength
0	0	0	0	NOP (no operation)	NOP (no operation)
0	0	0	1	Increase by 1 step	NOP
0	0	1	0	Decrease by 1 step	NOP
0	1	0	0	NOP	Increase by 1 step
1	0	0	0	NOP	Decrease by 1 step
0	1	0	1	Increase by 1 step	Increase by 1 step
0	1	1	0	Decrease by 1 step	Increase by 1 step
1	0	0	1	Increase by 1 step	Decrease by 1 step
1	0	1	0	Decrease by 1 step	Decrease by 1 step
Other Combinations				Reserved	

For proper operation of adjust mode, $WL = RL - 1 = AL + CL - 1$ clocks and t_{DS} / t_{DH} should be met as the following timing diagram. Input data pattern for adjustment, DT0 ~ DT3 is fixed and not affected by MRS addressing mode (i.e. sequential or interleave).

512Mb DDR2 SDRAM

OCD Adjust Mode

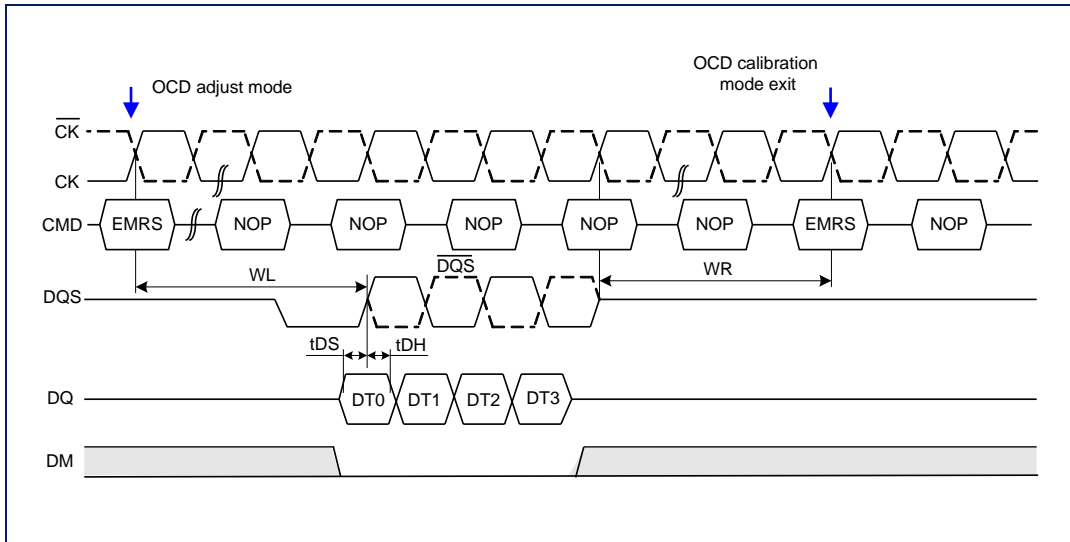

512Mb DDR2 SDRAM

Drive Mode

Drive mode, both Drive (1) and Drive (0), is used for controllers to measure DDR2 SDRAM Driver impedance before OCD impedance adjustment. In this mode, all outputs are driven out t_{OIT} after “enter drive mode” command and all output drivers are turned-off t_{OIT} after “OCD calibration mode exit” command as the following timing diagram.

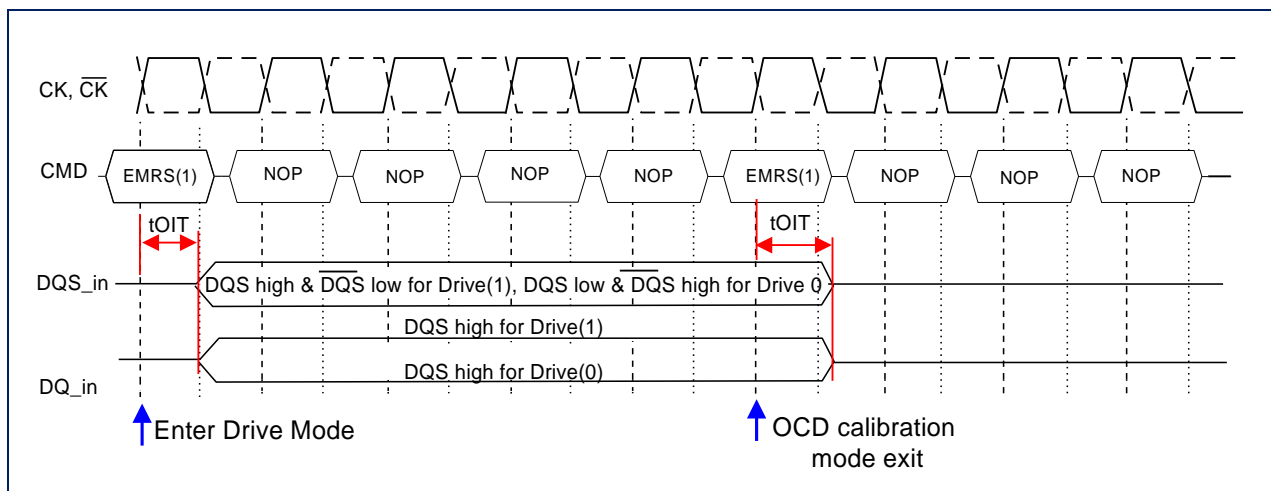

On-Die Termination (ODT)

ODT (On-Die Termination) is a feature that allows a DRAM to turn on/off termination resistance for each DQ, \overline{DQ} , DQS, \overline{DQS} , RDQS, \overline{RDQS} , and DM signal for x8 configurations via the ODT control pin. For x16 configuration ODT is applied to each DQ, UDQS, \overline{UDQS} , LDQS, \overline{LDQS} , UDM and LDM signal via the ODT control pin. The ODT feature is designed to improve signal integrity of the memory channel by allowing the DRAM controller to independently turn on/off termination resistance for any or all DRAM devices.

The ODT function can be used for all active and standby modes. ODT is turned off and not supported in Self-Refresh mode.

Functional Representation of ODT

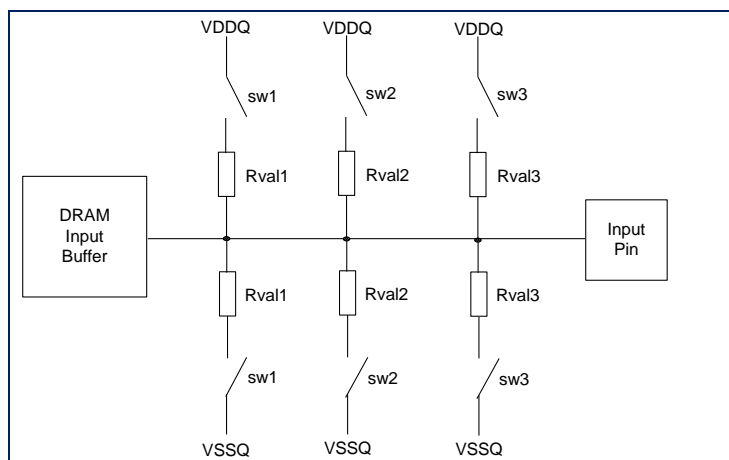

Switch sw1, sw2, or sw3 is enabled by the ODT pin. Selection between sw1, sw2, or sw3 is determined by “Rtt (nominal)” in EMRS.

Termination included on all DQs, DM, DQS, \overline{DQS} , RDQS, and \overline{RDQS} pins.

512Mb DDR2 SDRAM

ODT related timings

MRS command to ODT update delay

During normal operation the value of the effective termination resistance can be changed with an EMRS command. The update of the Rtt setting is done between tMOD, min and tMOD, max, and CKE must remain HIGH for the entire duration of tMOD window for proper operation. The timings are shown in the following timing diagram.

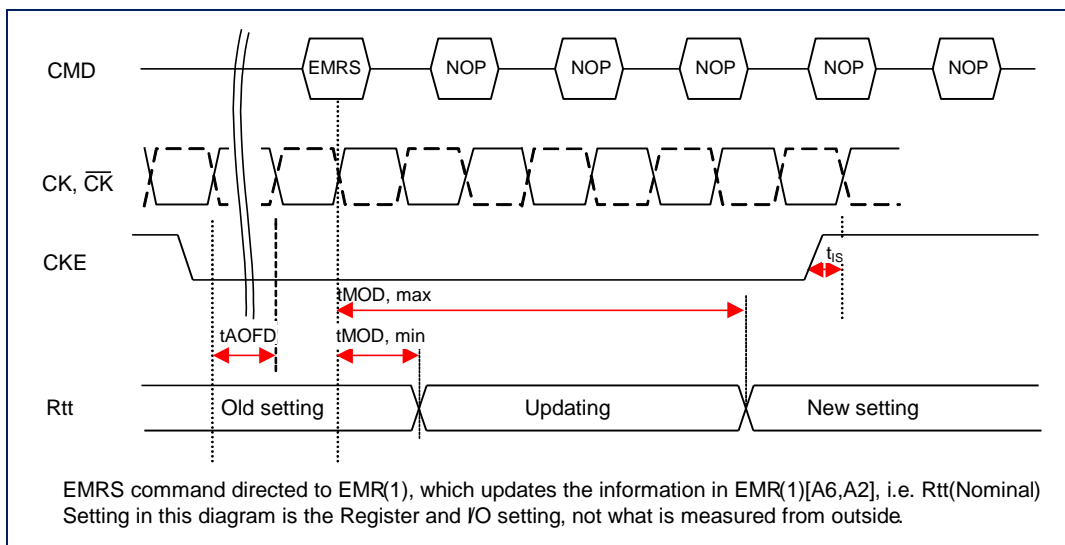

However, to prevent any impedance glitch on the channel, the following conditions must be met.

- tAOFD must be met before issuing the EMRS command.
- ODT must remain LOW for the entire duration of tMOD window, until tMOD, max is met.

Now the ODT is ready for normal operation with the new setting, and the ODT may be raised again to turn on the ODT.

Following timing diagram shows the proper Rtt update procedure.

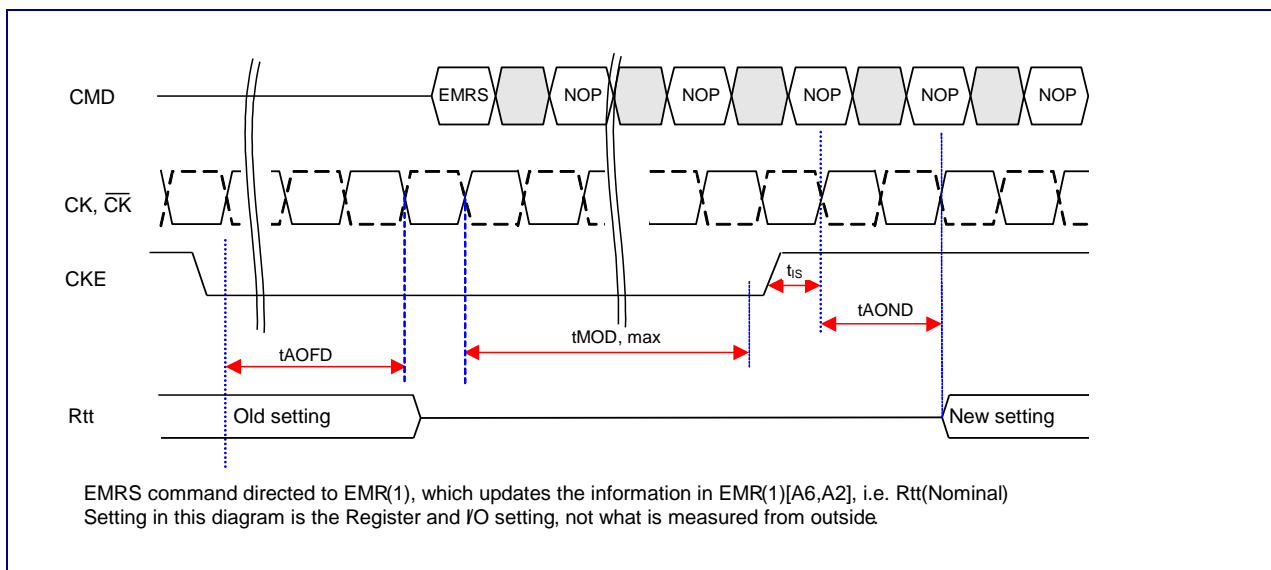

512Mb DDR2 SDRAM

ODT On/Off timings

ODT timing for active/standby mode

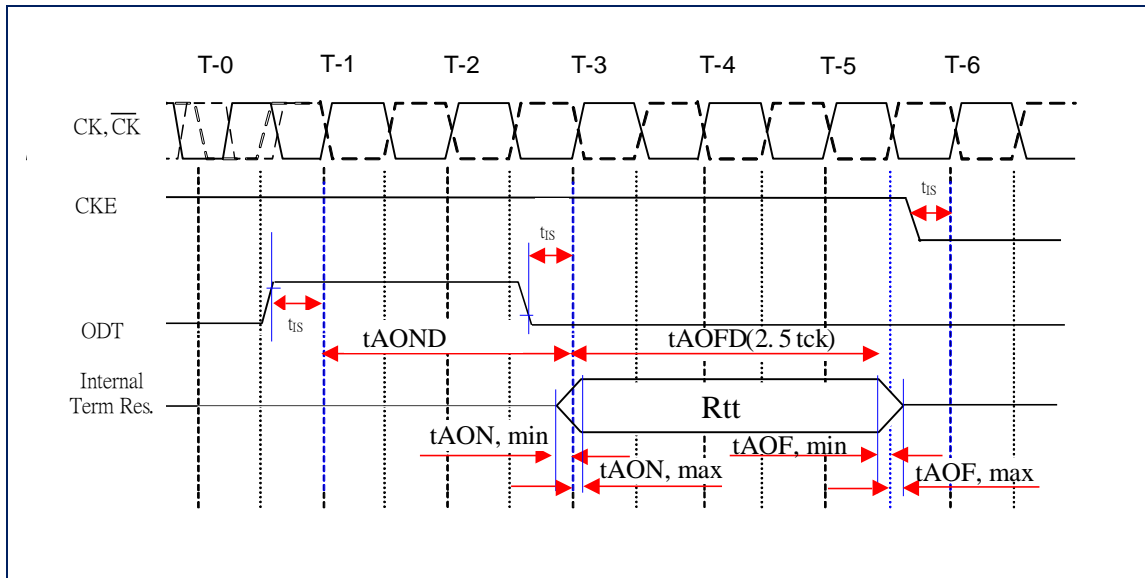

ODT Timing for Power-down mode

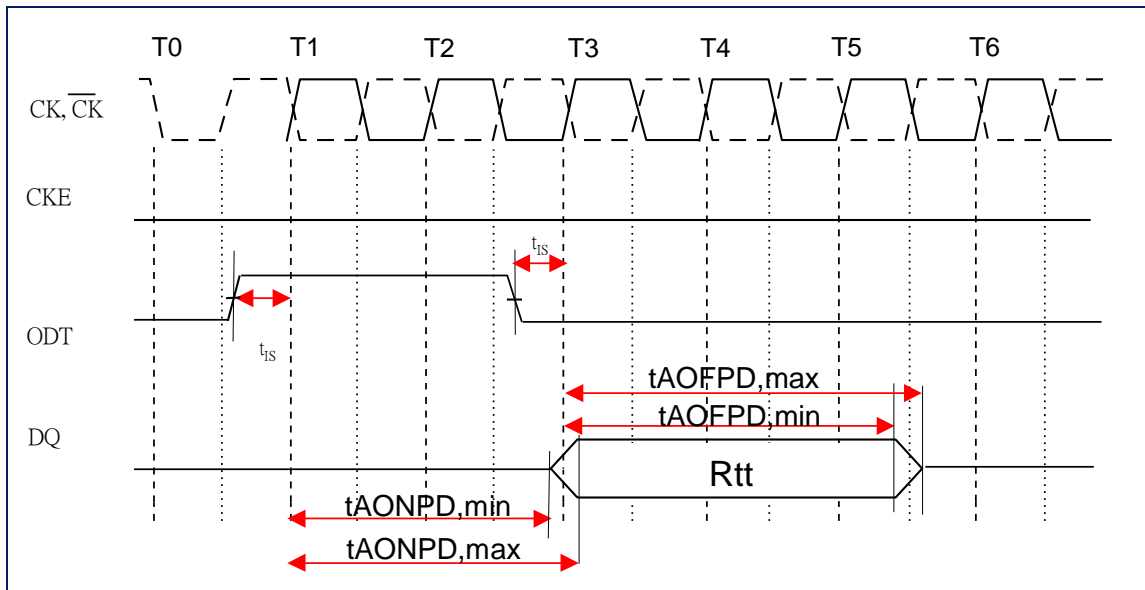

512Mb DDR2 SDRAM

Bank Activate Command

The Bank Activate command is issued by holding \overline{CAS} and \overline{WE} high plus \overline{CS} and \overline{RAS} low at the rising edge of the clock. The bank addresses BA0 ~ BA1 are used to select the desired bank. The row addresses A0 through A13 are used to determine which row to activate in the selected bank for and x8 organized components. For x16 components row addresses A0 through A12 have to be applied. The Bank Activate command must be applied before any Read or Write operation can be executed. Immediately after the bank active command, the DDR2 SDRAM can accept a read or write command (with or without Auto-Precharge) on the following clock cycle. If an R/W command is issued to a bank that has not satisfied the t_{RCDmin} specification, then additive latency must be programmed into the device to delay the R/W command which is internally issued to the device. The additive latency value must be chosen to assure t_{RCDmin} is satisfied. Additive latencies of 0, 1, 2, 3, 4, 5, and 6 are supported. Once a bank has been activated it must be precharged before another Bank Activate command can be applied to the same bank. The bank active and precharge times are defined as t_{RAS} and t_{RP} , respectively. The minimum time interval between successive Bank Activate commands to the same bank is determined (t_{RC}). The minimum time interval between Bank Active commands, to other bank, is the Bank A to Bank B delay time (t_{RRD}).

In order to ensure that 8 bank devices do not exceed the instantaneous current supplying capability of 4 bank devices, certain restrictions on operation of the 8 bank devices must be observed. There are two rules. One for restricting the number of sequential ACT commands that can be issued and another for allowing more time for RAS precharge for a Precharge All command. The rules are list as follow:

* 8 bank device sequential Bank Activation Restriction: No more than 4 banks may be activated in a rolling tFAW window. Converting to clocks is done by dividing tFAW by tCK and rounding up to next integer value. As an example of the rolling window, if (tFAW/tCK) rounds up to 10 clocks, and an activate command is issued in clock N, no more than three further activate commands may be issued in clock N+1 through N+9.

*8 bank device Precharge All Allowance: t_{RP} for a Precharge All command for an 8 Bank device will equal to $t_{RP} + t_{CK}$, where t_{RP} is the value for a single bank pre-charge.

Bank Activate Command Cycle: $t_{RCD} = 3$, $AL = 2$, $t_{RP} = 3$, $t_{RRD} = 2$, $t_{CCD} = 2$

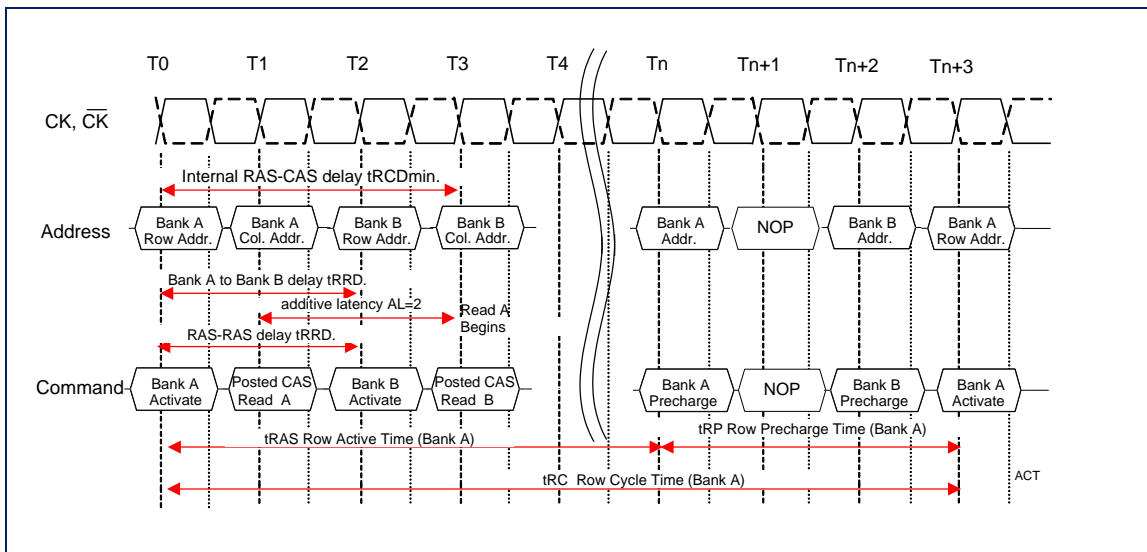

512Mb DDR2 SDRAM

Read and Write Commands and Access Modes

After a bank has been activated, a read or write cycle can be executed. This is accomplished by setting \overline{RAS} high, \overline{CS} and \overline{CAS} low at the clock's rising edge. \overline{WE} must also be defined at this time to determine whether the access cycle is a read operation (\overline{WE} high) or a write operation (\overline{WE} low). The DDR2 SDRAM provides a fast column access operation. A single Read or Write Command will initiate a serial read or write operation on successive clock cycles. The boundary of the burst cycle is restricted to specific segments of the page length.

A new burst access must not interrupt the previous 4 bit burst operation in case of BL = 4 setting. However, in case of BL=8 setting, two cases of interrupt by a new burst access are allowed, one reads interrupted by a read, the other writes interrupted by a write with 4 bit burst boundary respectively, and the minimum \overline{CAS} to \overline{CAS} delay (t_{CCD}) is minimum 2 clocks for read or write cycles.

Posted \overline{CAS}

Posted \overline{CAS} operation is supported to make command and data bus efficient for sustainable bandwidths in DDR2 SDRAM. In this operation, the DDR2 SDRAM allows a Read or Write command to be issued immediately after the \overline{RAS} bank activate command (or any time during the \overline{RAS} to \overline{CAS} delay time, t_{RCD} , period). The command is held for the time of the Additive Latency (AL) before it is issued inside the device. The Read Latency (RL) is the sum of AL and the \overline{CAS} latency (CL). Therefore if a user chooses to issue a Read/Write command before the t_{RCDmin} , then AL greater than 0 must be written into the EMRS (1). The Write Latency (WL) is always defined as $RL - 1$ (Read Latency -1) where Read Latency is defined as the sum of Additive Latency plus \overline{CAS} latency ($RL=AL+CL$). If a user chooses to issue a Read command after the t_{RCDmin} period, the Read Latency is also defined as $RL = AL + CL$.

Example of posted \overline{CAS} operation:

Read followed by a write to the same bank:

AL = 2 and CL = 3, RL = (AL + CL) = 5, WL = (RL - 1) = 4, BL = 4

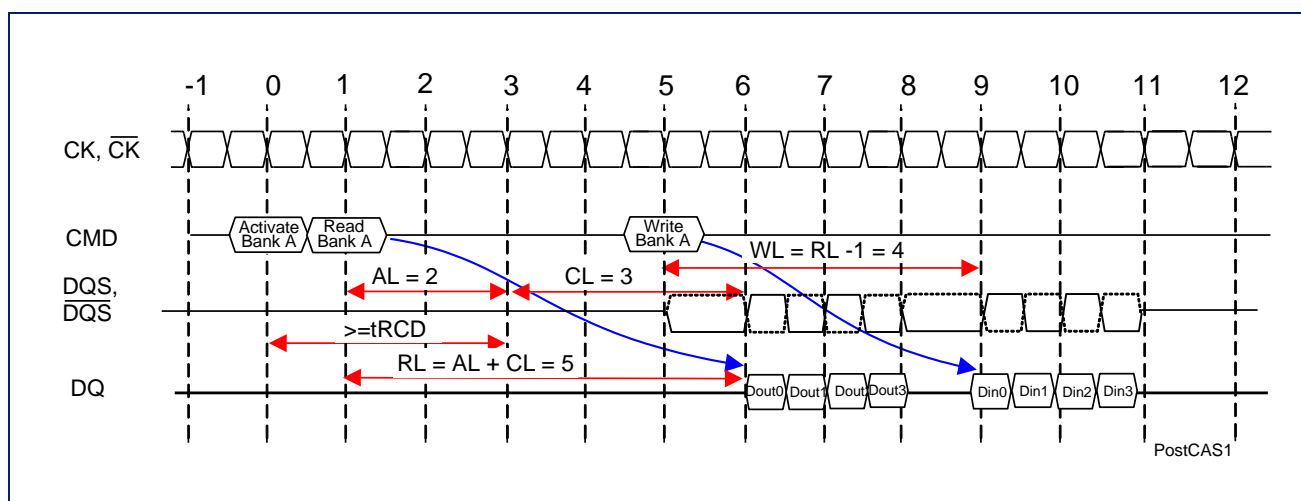

512Mb DDR2 SDRAM

Read followed by a write to the same bank:

$AL = 0, CL = 3, RL = (AL + CL) = 3, WL = (RL - 1) = 2, BL = 4$

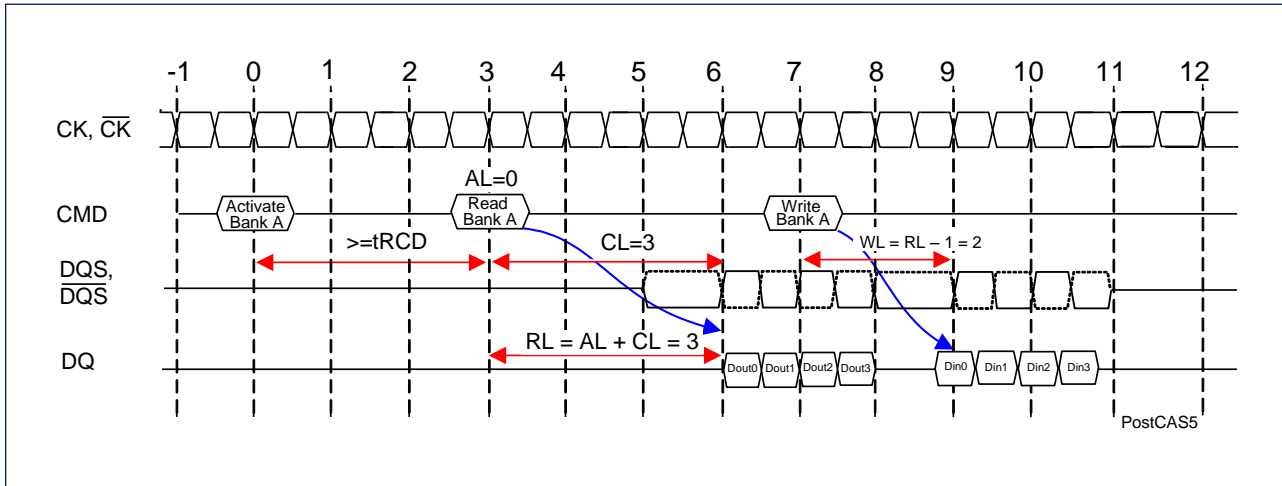

512Mb DDR2 SDRAM

Burst Mode Operation

Burst mode operation is used to provide a constant flow of data to memory locations (write cycle), or from memory locations (read cycle). The parameters that define how the burst mode will operate are burst sequence and burst length. The DDR2 SDRAM supports 4 bit and 8 bit burst modes only. For 8 bit burst mode, full interleave address ordering is supported, however, sequential address ordering is nibble based for ease of implementation. The burst type, either sequential or interleaved, is programmable and defined by the address bit 3 (A3) of the MRS. Seamless burst read or write operations are supported. Interruption of a burst read or write operation is prohibited, when burst length = 4 is programmed. For burst interruption of a read or write burst when burst length = 8 is used, see the "Burst Interruption" section of this datasheet. A Burst Stop command is not supported on DDR2 SDRAM devices.

Burst Length and Sequence

Burst Length	Starting Address (A2 A1 A0)	Sequential Addressing (decimal)	Interleave Addressing (decimal)
4	x 0 0	0, 1, 2, 3	0, 1, 2, 3
	x 0 1	1, 2, 3, 0	1, 0, 3, 2
	x 1 0	2, 3, 0, 1	2, 3, 0, 1
	x 1 1	3, 0, 1, 2	3, 2, 1, 0
8	0 0 0	0, 1, 2, 3, 4, 5, 6, 7	0, 1, 2, 3, 4, 5, 6, 7
	0 0 1	1, 2, 3, 0, 5, 6, 7, 4	1, 0, 3, 2, 5, 4, 7, 6
	0 1 0	2, 3, 0, 1, 6, 7, 4, 5	2, 3, 0, 1, 6, 7, 4, 5
	0 1 1	3, 0, 1, 2, 7, 4, 5, 6	3, 2, 1, 0, 7, 6, 5, 4
	1 0 0	4, 5, 6, 7, 0, 1, 2, 3	4, 5, 6, 7, 0, 1, 2, 3
	1 0 1	5, 6, 7, 4, 1, 2, 3, 0	5, 4, 7, 6, 1, 0, 3, 2
	1 1 0	6, 7, 4, 5, 2, 3, 0, 1	6, 7, 4, 5, 2, 3, 0, 1
	1 1 1	7, 4, 5, 6, 3, 0, 1, 2	7, 6, 5, 4, 3, 2, 1, 0
Note: 1) Page length is a function of I/O organization 64Mb X 16 organization (CA0-CA9); Page Size = 2K Byte; Page Length = 1024 128Mb X 8 organization (CA0-CA9); Page Size = 1K Byte; Page Length = 1024 256Mb x 4 organization (CA0-CA9, CA11); Page Size = 1K Byte; Page Length = 2048 2) Order of burst access for sequential addressing is "nibble-based" and therefore different from SDR or DDR components			

512Mb DDR2 SDRAM

Burst Read Command

The Burst Read command is initiated by having \overline{CS} and \overline{CAS} low while holding \overline{RAS} and \overline{WE} high at the rising edge of the clock. The address inputs determine the starting column address for the burst. The delay from the start of the command until the data from the first cell appears on the outputs is equal to the value of the read latency (RL). The data strobe output (DQS) is driven low one clock cycle before valid data (DQ) is driven onto the data bus. The first bit of the burst is synchronized with the rising edge of the data strobe (DQS). Each subsequent data-out appears on the DQ pin in phase with the DQS signal in a source synchronous manner. The RL is equal to an additive latency (AL) plus \overline{CAS} latency (CL). The CL is defined by the Mode Register Set (MRS). The AL is defined by the Extended Mode Register Set (EMRS (1))

Basic Burst Read Timing

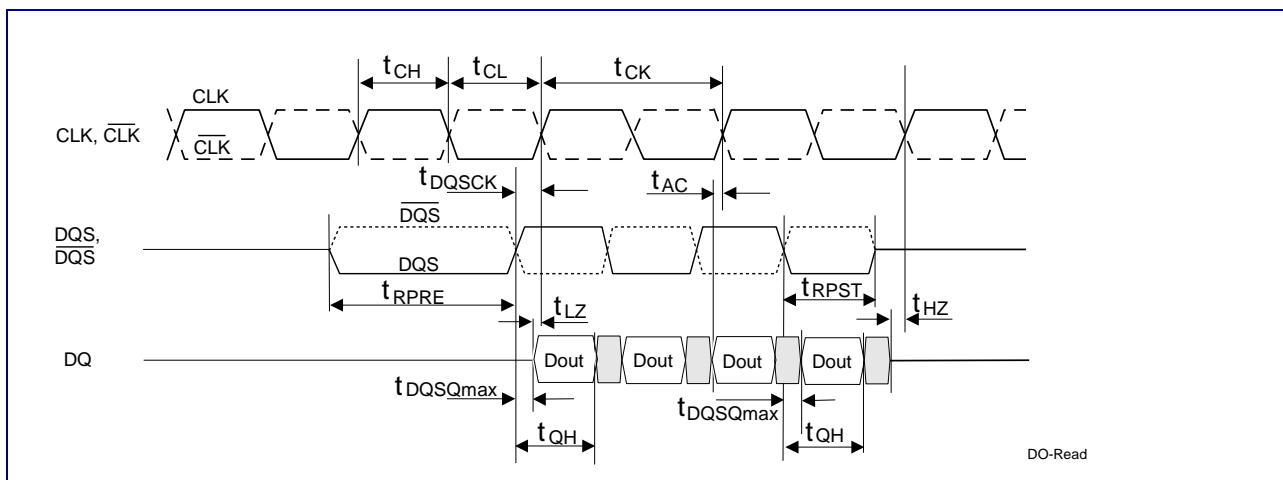

Examples:

Burst Read Operation: RL = 5 (AL = 2, CL = 3, BL = 4)

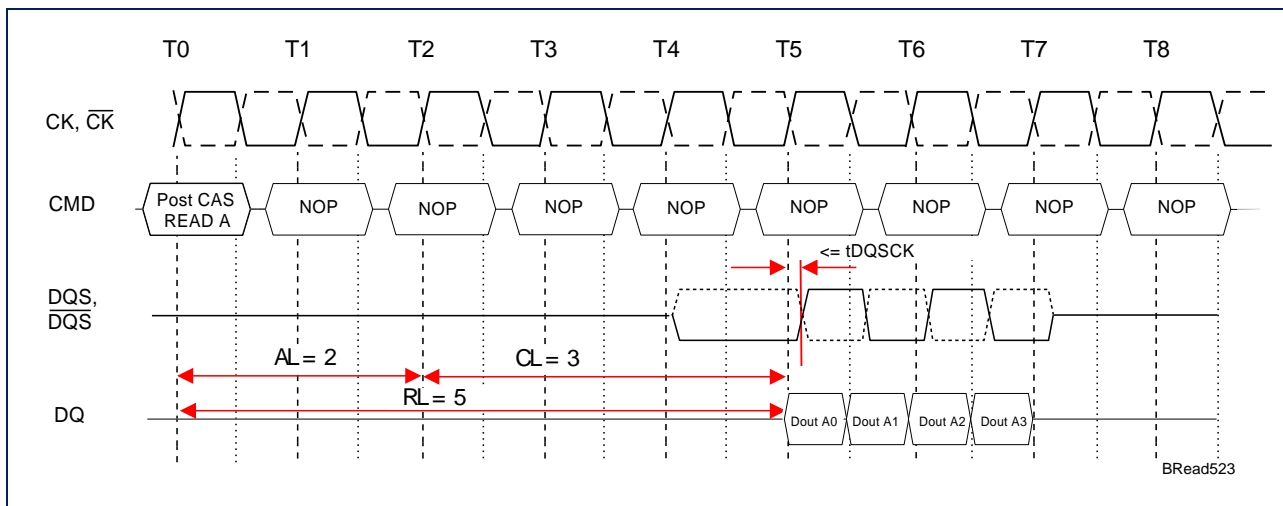

512Mb DDR2 SDRAM

Burst Read Operation: RL = 3 (AL = 0, CL = 3, BL = 8)

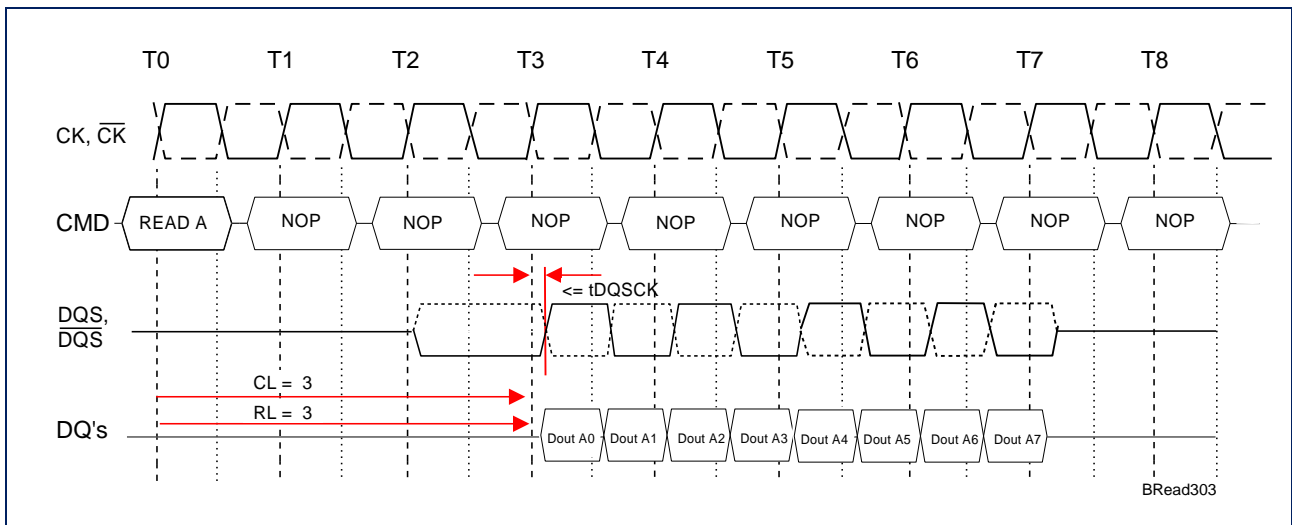

Burst Read followed by Burst Write : RL = 5, WL = (RL-1) = 4, BL = 4

The minimum time from the burst read command to the burst write command is defined by a read-to-write-turn-around time (t_{RTW}), which is 4 clocks in case of BL=4 operation, 6 clocks in case of BL=8 operation.

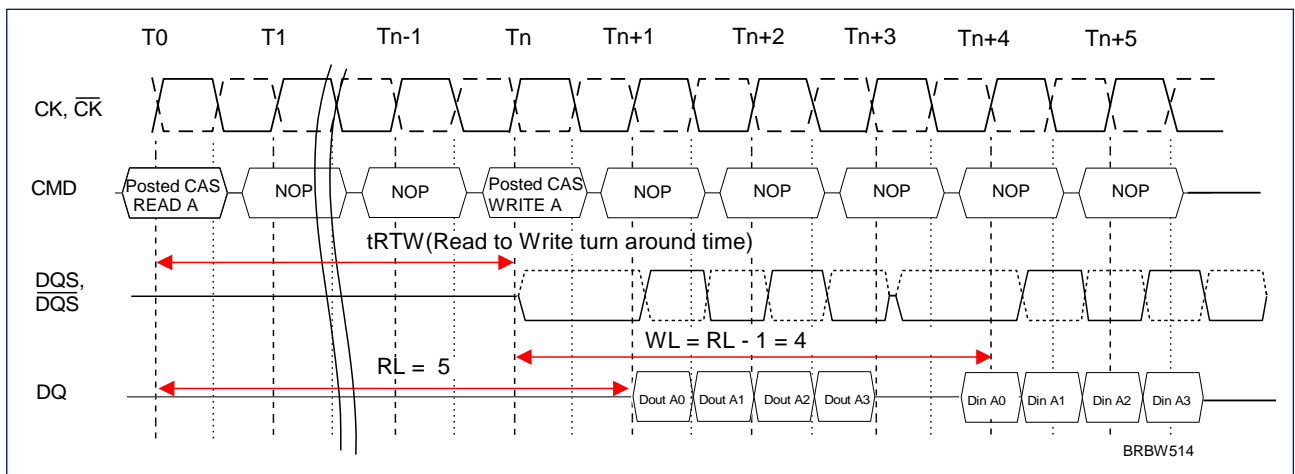

512Mb DDR2 SDRAM

Seamless Burst Read Operation: RL = 5, AL = 2, CL = 3, BL = 4

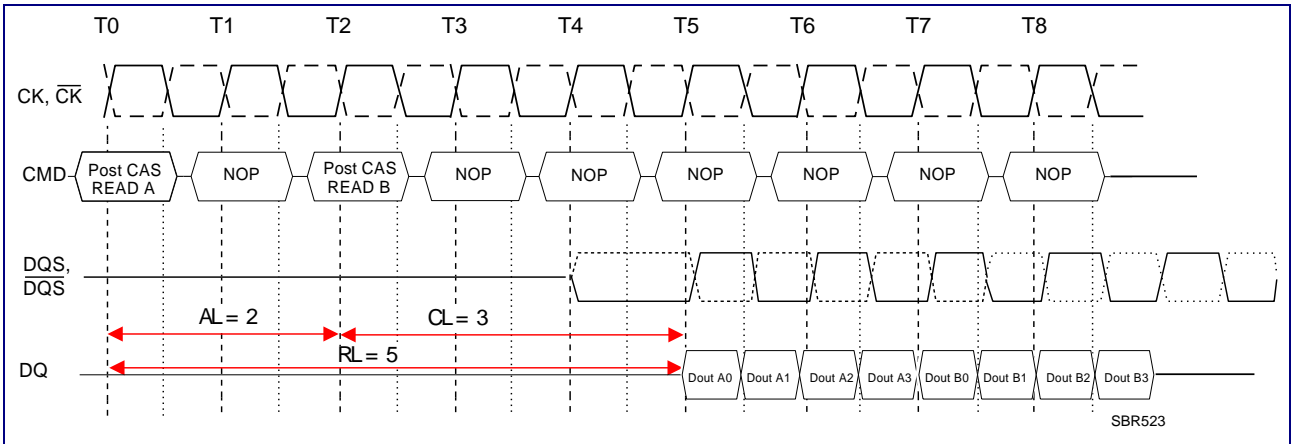

The seamless burst read operation's supported by enabling a read command at every clock for BL=4 operation, and every 4 clock for BL=8 operation. This operation allows regardless of same or different banks as long as the banks activated.

Burst Write Command

The Burst Write command is initiated by having CS, CAS and WE low while holding RAS high at the rising edge of the clock. The address inputs determine the starting column address. Write latency (WL) is defined by a read latency (RL) minus one and is equal to $(AL + CL - 1)$. A data strobe signal (DQS) has to be driven low (preamble) a time t_{WPRE} prior to the WL. The first data bit of the burst cycle must be applied to the DQ pins at the first rising edge of the DQS following the preamble. The t_{DQSS} specification must be satisfied for write cycles. The subsequent burst bit data are issued on successive edges of the DQS until the burst length is completed, which is 4 or 8 bit burst. When the burst has finished, any additional data supplied to the DQ pins will be ignored. The DQ signal is ignored after the burst write operation is complete. The time from the completion of the burst write to bank precharge is named "write recovery time" (WR).

DDR2 SDRAM pin timings are specified for either single ended mode or differential mode depending on the setting of the EMRS "Enable DQS" mode bit; timing advantages of differential mode are realized in system design. The method by which the DDR2 SDRAM pin timing measured is mode dependent.

Basic Burst Write Timing

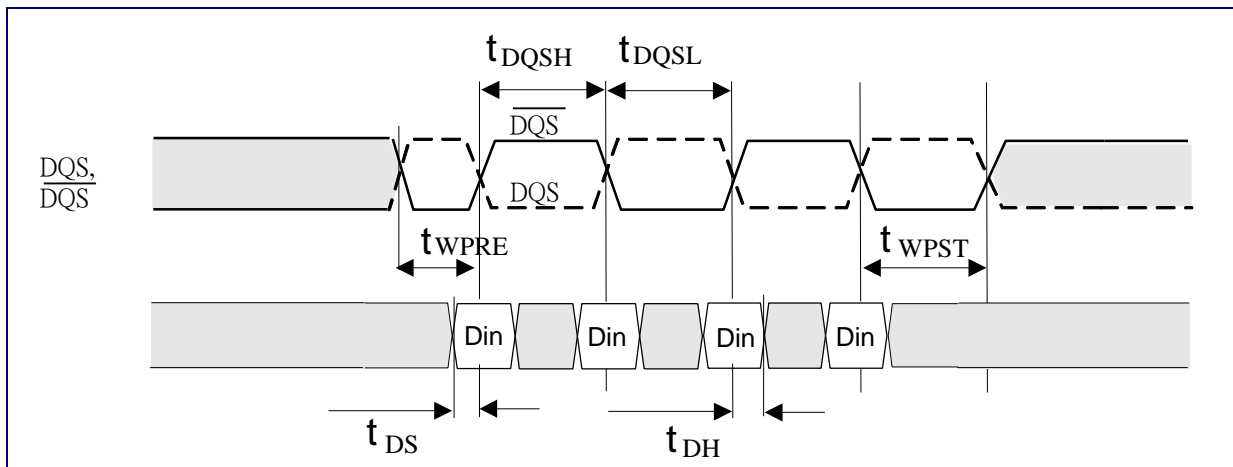

512Mb DDR2 SDRAM

Example:

Burst Write Operation: $RL = 5$ ($AL = 2, CL = 3$), $WL = 4, BL = 4$

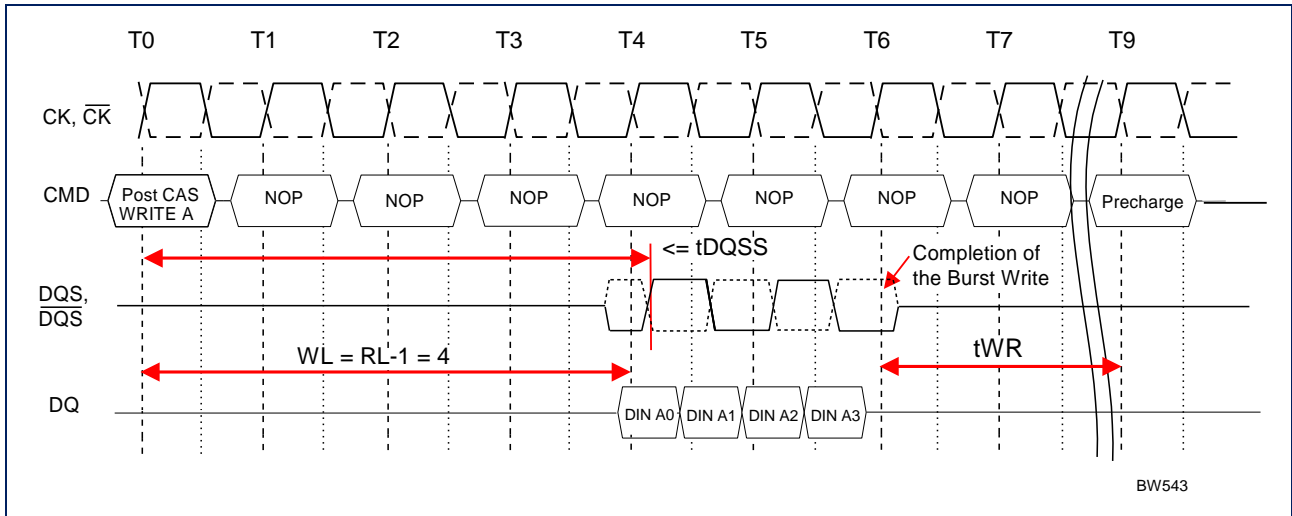

512Mb DDR2 SDRAM

Burst Read followed by Burst Write : $RL = 5, WL = (RL-1) = 4, BL = 4$

The minimum time from the burst read command to the burst write command is defined by a read-to-write-turn-around time(t_{RTW}), which is 4 clocks in case of $BL=4$ operation, 6 clocks in case of $BL=8$ operation.

Burst Write followed by Burst Read: $RL = 5 (AL = 2, CL = 3), WL = 4, t_{WTR} = 2, BL = 4$

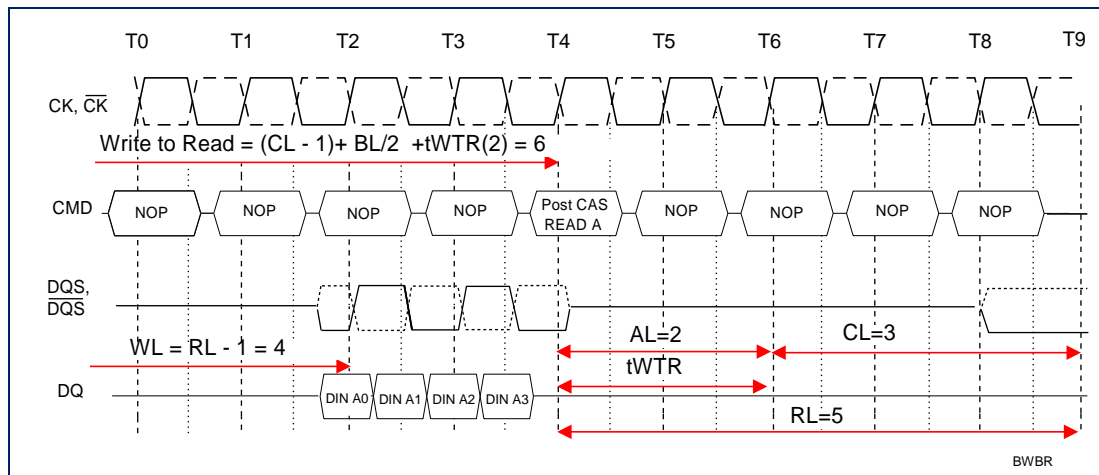

The minimum number of clocks from the burst write command to the burst read command is $(CL - 1) + BL/2 + t_{WTR}$ where t_{WTR} is the write-to-read turn-around time t_{WTR} expressed in clock cycles. The t_{WTR} is not a write recovery time (t_{WR}) but the time required to transfer 4 bit write data from the input buffer into sense amplifiers in the array.

Seamless Burst Write Operation: $RL = 5, WL = 4, BL = 4$

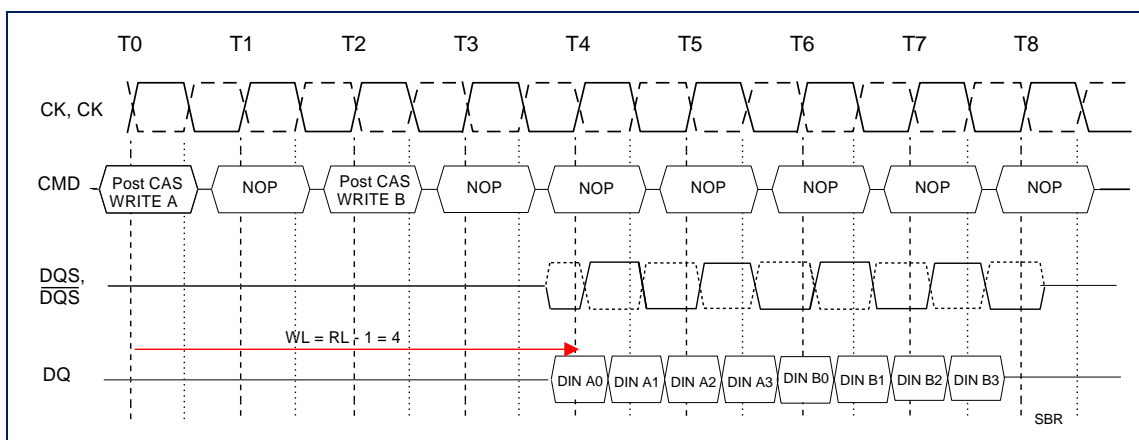

The seamless burst write operation is supported by enabling a write command every $BL / 2$ number of clocks. This operation is allowed regardless of same or different banks as long as the banks are activated.

512Mb DDR2 SDRAM

Write Data Mask

One write data mask input (DM) pin for each 8 data bits (DQ) will be supported on DDR2 SDRAMs, consistent with the implementation on DDR SDRAMs. It has identical timings on write operations as the data bits, and though used in a uni-directional manner, is internally loaded identically to data bits to insure matched system timing. DM of x4 and x16 bit organization is not used during read cycles. However, DM of x8 bit organization can be used as RDQS during read cycles by EMRS (1) setting.

Write Data Mask Timing

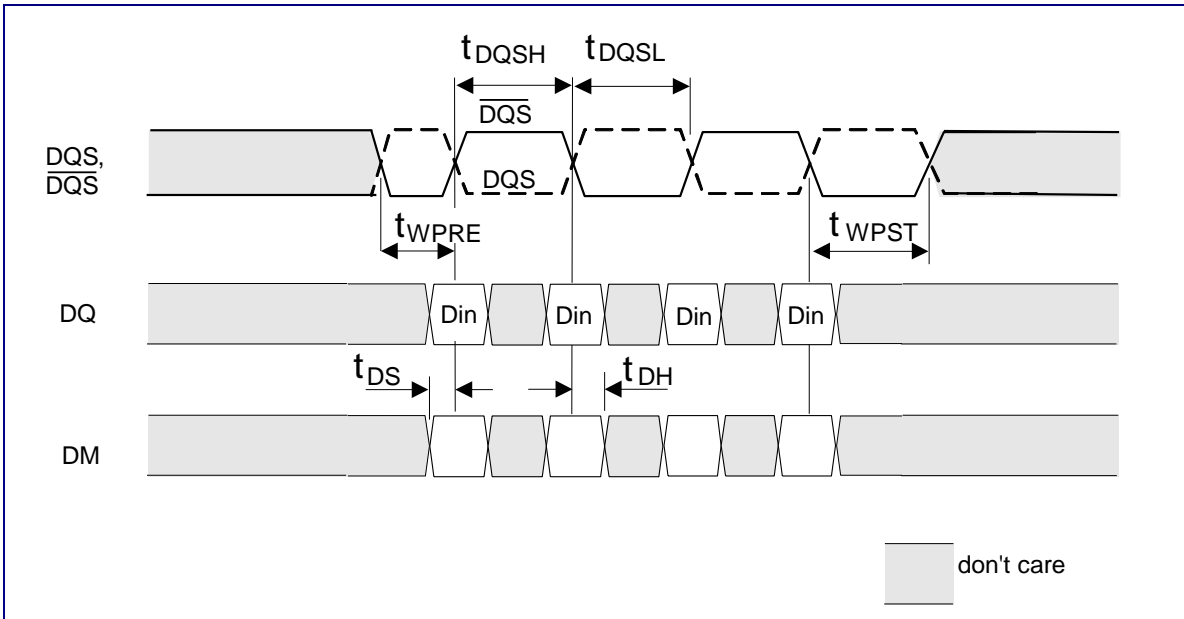

Burst Write Operation with Data Mask: RL = 3 (AL = 0, CL = 3), WL = 2, $t_{WR} = 3$, BL = 4

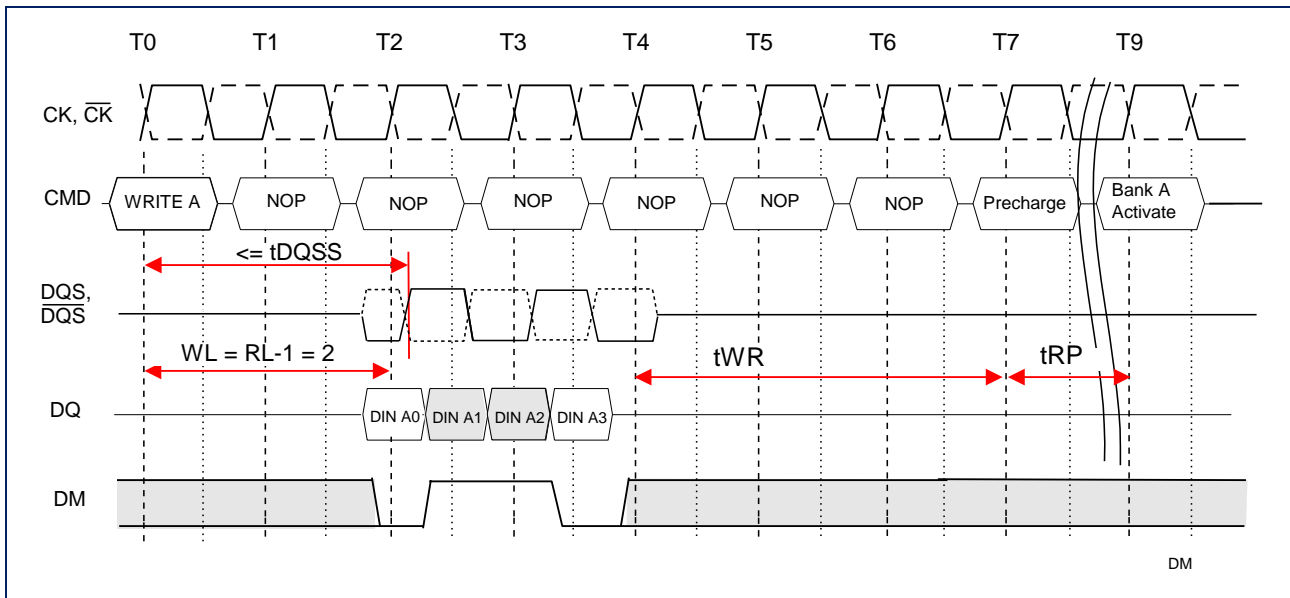

512Mb DDR2 SDRAM

Burst Interruption

Interruption of a read or write burst is prohibited for burst length of 4 and only allowed for burst length of 8 under the following conditions:

1. A Read Burst of 8 can only be interrupted by another Read command. Read burst interruption by a Write or Precharge Command is prohibited.
2. A Write Burst of 8 can only be interrupted by another Write command. Write burst interruption by a Read or Precharge Command is prohibited.
3. Read burst interrupt occur exactly two clocks after the previous Read command. Any other Read burst interrupt timings are prohibited.
4. Write burst interrupt occur exactly two clocks after the previous Write command. Any other Read burst interrupt timings are prohibited.
5. Read or Write burst interruption is allowed to any bank inside the DDR2 SDRAM.
6. Read or Write burst with Auto-Precharge enabled is not allowed to be interrupted.
7. Read burst interruption is allowed by a Read with Auto-Precharge command.
8. Write burst interruption is allowed by a Write with Auto-Precharge command.
9. All command timings are referenced to burst length set in the mode register. They are not referenced to the actual burst. For example, Minimum Read to Precharge timing is $AL + BL/2$ where BL is the burst length set in the mode register and not the actual burst (which is shorter because of interrupt). Minimum Write to Precharge timing is $WL + BL/2 + t_{WR}$, where t_{WR} starts with the rising clock after the un-interrupted burst end and not from the end of the actual burst end.

512Mb DDR2 SDRAM

Examples:

Read Burst Interrupt Timing Example: (CL = 3, AL = 0, RL = 3, BL = 8)

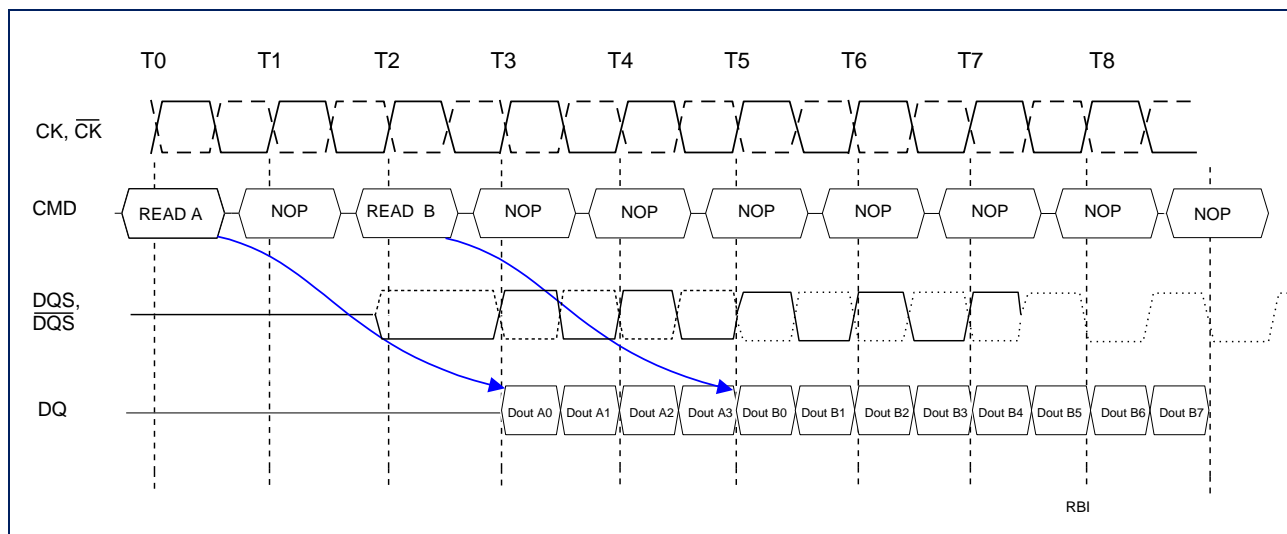

Write Burst Interrupt Timing Example: (CL = 3, AL = 0, WL = 2, BL = 8)

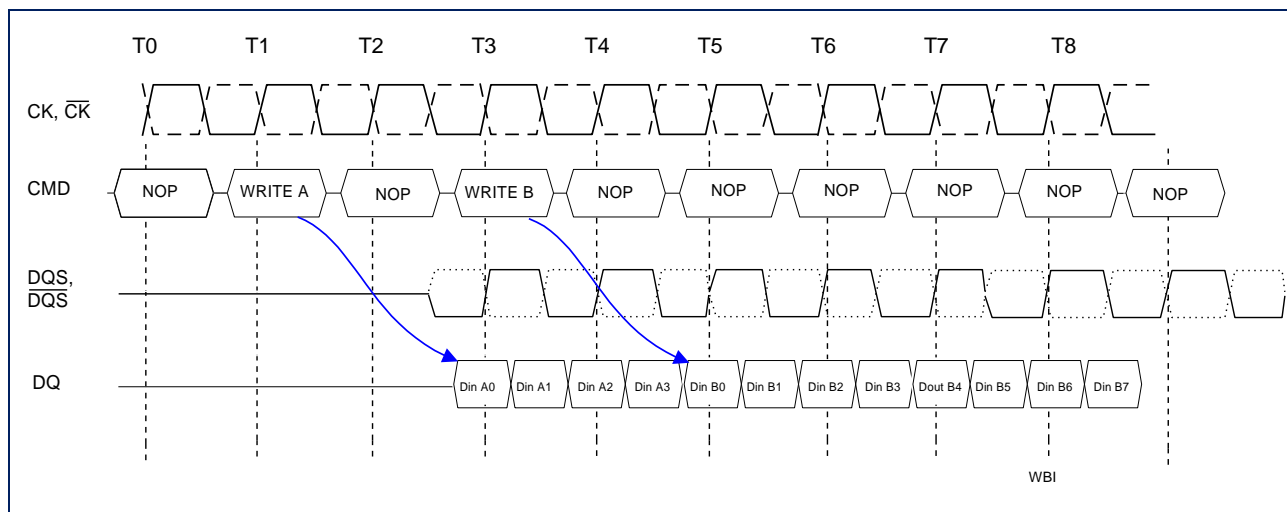

512Mb DDR2 SDRAM

Precharge Command

The Precharge Command is used to precharge or close a bank that has been activated. The Precharge Command is triggered when CS, RAS and WE are low and CAS is high at the rising edge of the clock. The Pre-charge Command can be used to precharge each bank independently or all banks simultaneously. Three address bits A10, BA0, and BA1 are used to define which bank to precharge when the command is issued.

Bank Selection for Precharge by Address Bit

A10	BA1	BA0	Precharge Bank(s)
LOW	LOW	LOW	Bank 0 only
LOW	LOW	HIGH	Bank 1 only
LOW	HIGH	LOW	Bank 2 only
LOW	HIGH	HIGH	Bank 3 only
HIGH	Don't Care	Don't Care	all banks

Burst Read Operation Followed by a Precharge

Minimum Read to Precharge command spacing to the same bank = $AL + BL/2 + \max(RTP, 2) - 2$ clocks.

For the earliest possible precharge, the Precharge command may be issued on the rising edge which is "Additive Latency (AL) + BL/2 clocks" after a Read Command, as long as the minimum t_{RAS} timing is satisfied.

The minimum Read to Precharge spacing has also to satisfy a minimum analog time from the rising clock edge that initiates the last 4-bit prefetch of a Read to Precharge command. This time is call t_{RTP} (Read to Precharge). For BL=4 this is the time from the actual read (AL after the Read command) to Precharge command. For BL=8 this is the time from AL + 2 clocks after the Read to the Precharge command.

512Mb DDR2 SDRAM

Examples:

Burst Read Operation Followed by Precharge: RL = 4 (AL = 1, CL = 3), BL = 4, $t_{RTP} \leq 2$ clocks

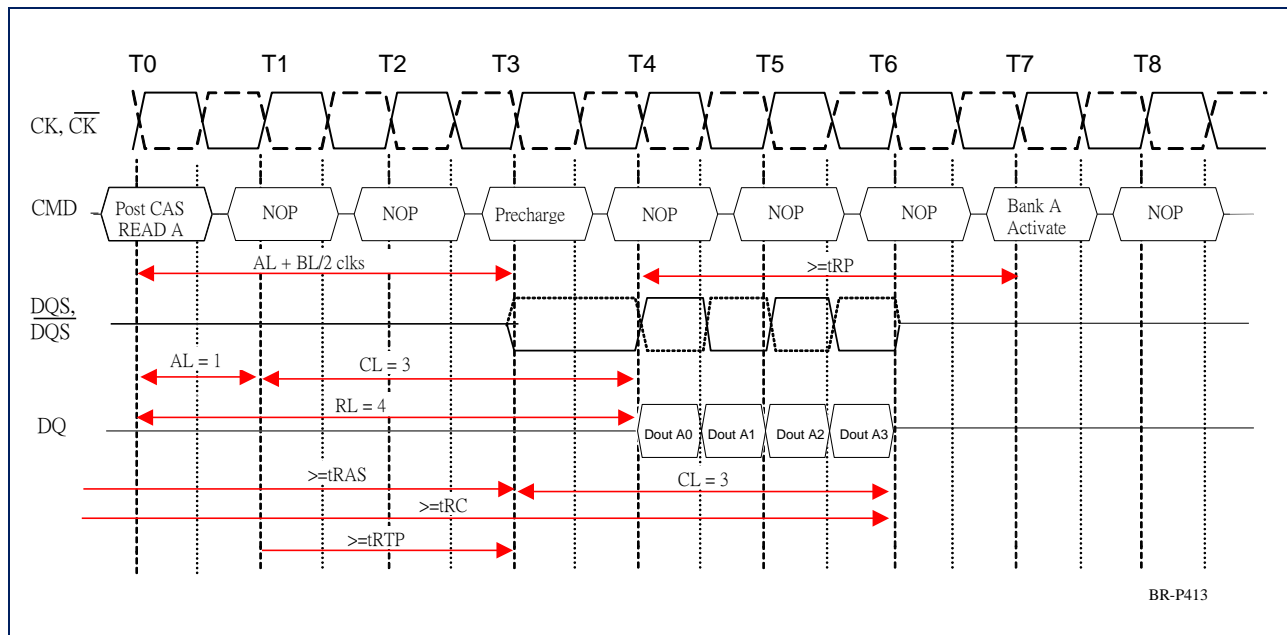

Burst Read Operation Followed by Precharge: RL = 4 (AL = 1, CL = 3), BL = 8, $t_{RTP} \leq 2$ clocks

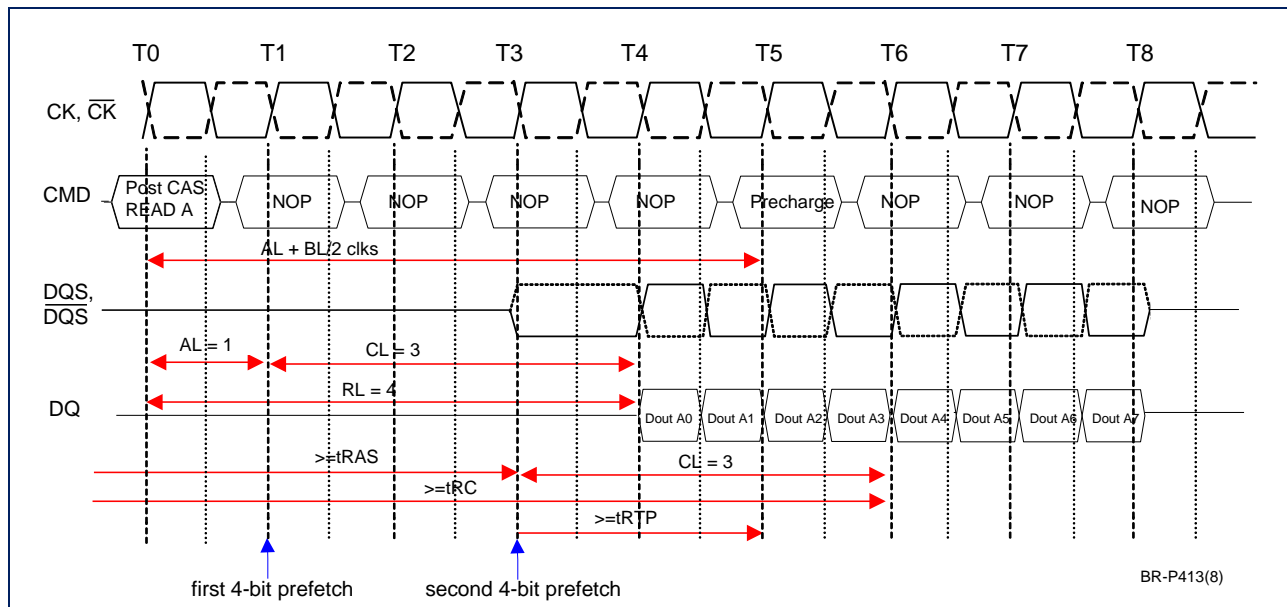

512Mb DDR2 SDRAM

Burst Read Operation Followed by Precharge: RL = 5 (AL = 2, CL = 3), BL = 4, $t_{RTP} \leq 2$ clocks

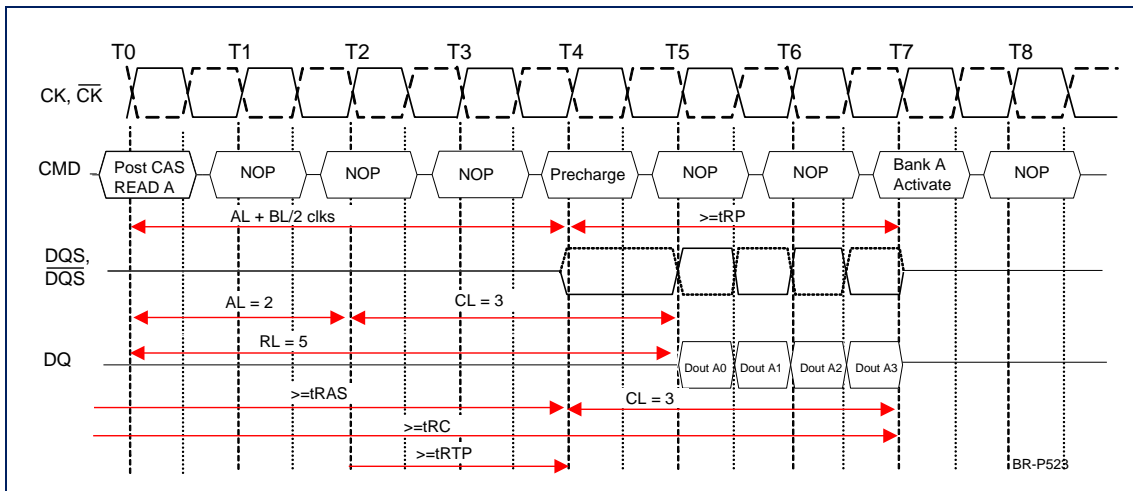

Burst Read Operation Followed by Precharge: RL = 6, (AL = 2, CL = 4), BL = 4, $t_{RTP} \leq 2$ clocks

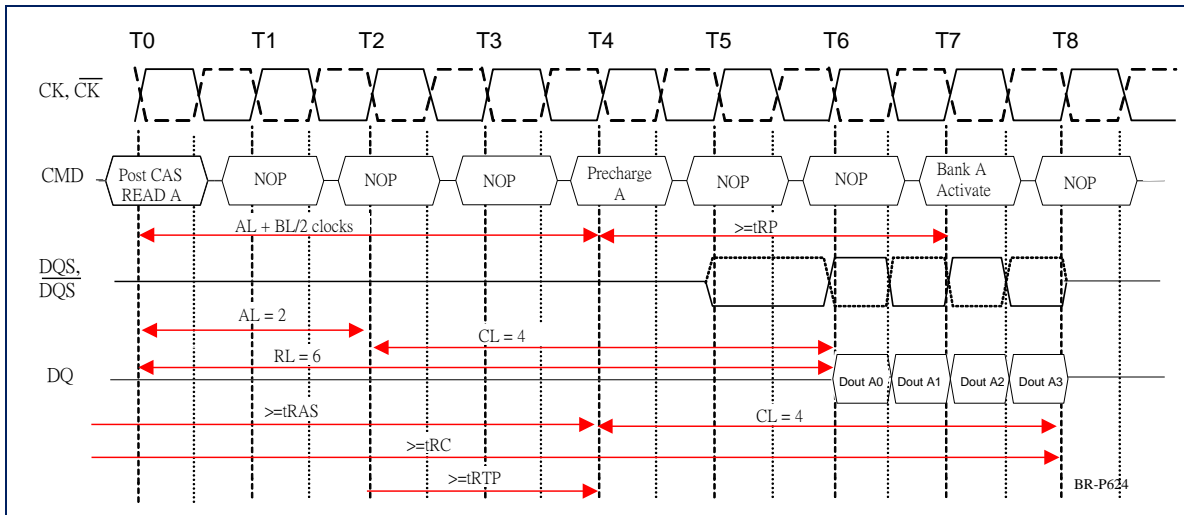

512Mb DDR2 SDRAM

Burst Read Operation Followed by Precharge: RL = 4, (AL = 0, CL = 4), BL = 8, $t_{RTP} > 2$ clocks

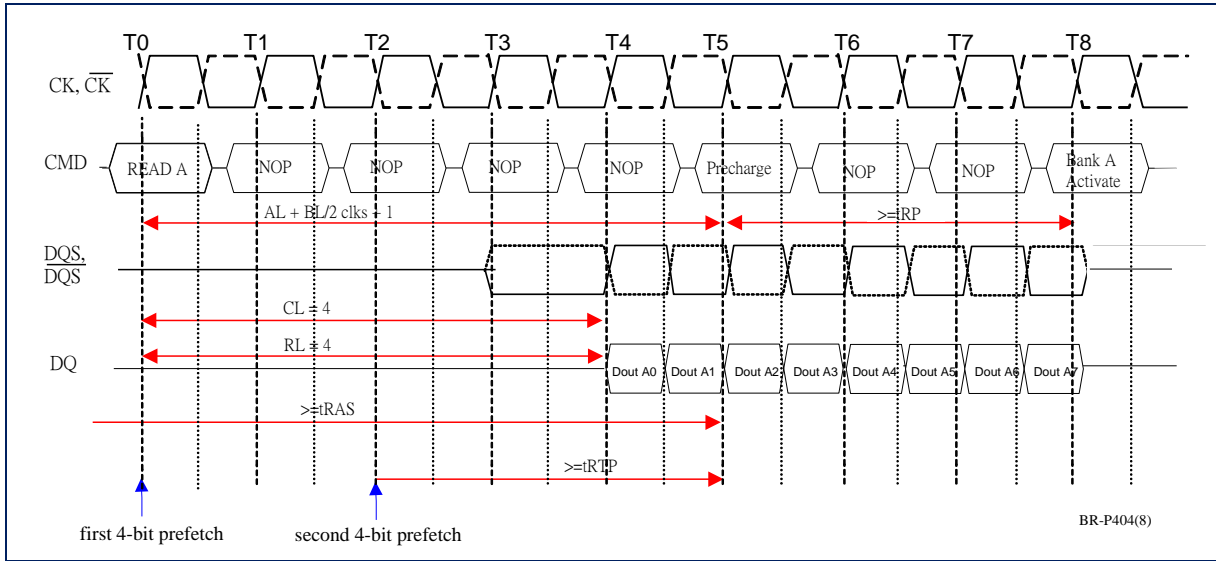

Burst Write followed by Precharge

Minimum Write to Precharge command spacing to the same bank = $WL + BL/2 + t_{WR}$. For write cycles, a delay must be satisfied from the completion of the last burst write cycle until the Precharge command can be issued. This delay is known as a write recovery time (t_{WR}) referenced from the completion of the burst write to the Precharge command. No Precharge command should be issued prior to the t_{WR} delay, as DDR2 SDRAM does not support any burst interrupt by a Precharge command. t_{WR} is an analog timing parameter (see the AC table in this datasheet) and is not the programmed value for t_{WR} in the MRS.

Examples:

Burst Write followed by Precharge : $WL = (RL - 1) = 3, BL = 4, t_{WR} = 3$

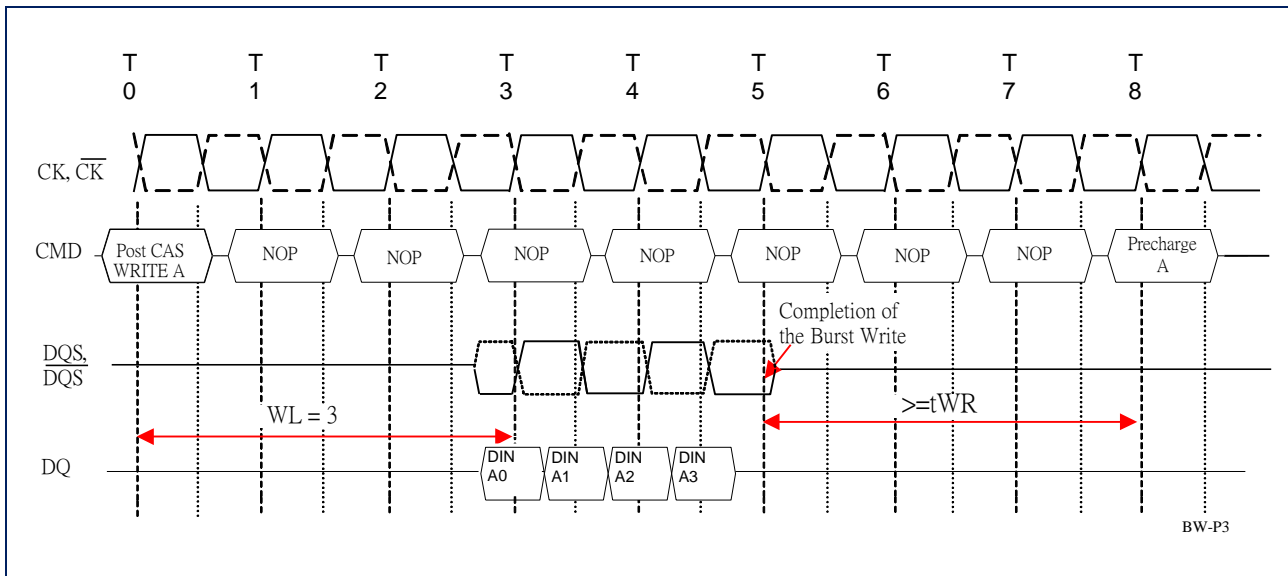

512Mb DDR2 SDRAM

Burst Write followed by Precharge : $WL = (RL - 1) = 4$, $BL = 4$, $t_{WR} = 3$

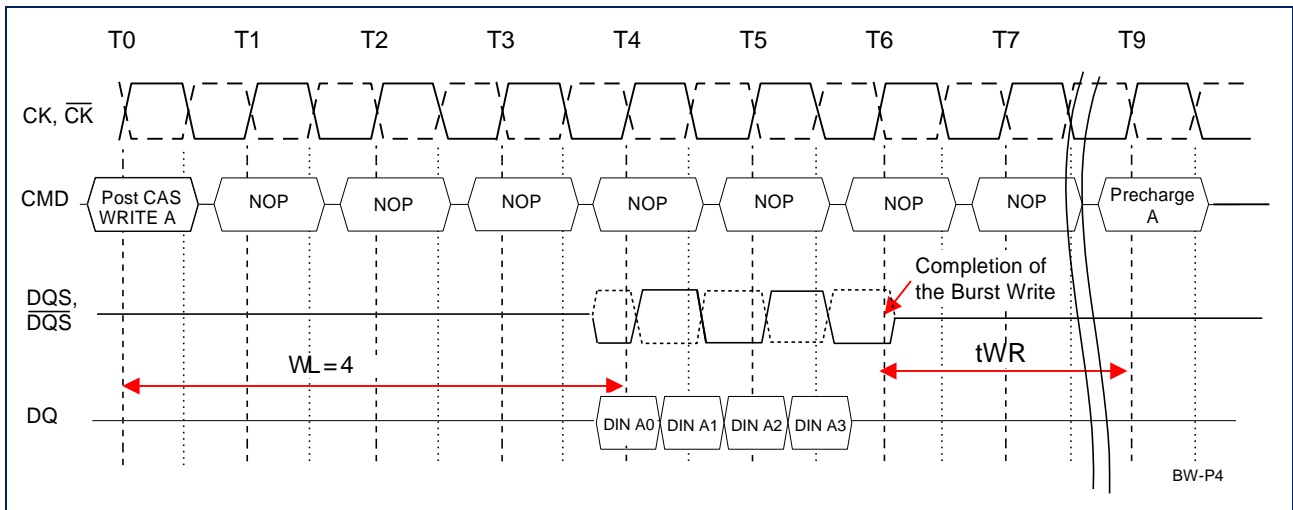

512Mb DDR2 SDRAM

Auto-Precharge Operation

Before a new row in an active bank can be opened, the active bank must be precharged using either the Pre-charge Command or the Auto-Precharge function. When a Read or a Write Command is given to the DDR2 SDRAM, the $\overline{\text{CAS}}$ timing accepts one extra address, column address A10, to allow the active bank to automatically begin precharge at the earliest possible moment during the burst read or write cycle. If A10 is low when the Read or Write Command is issued, then normal Read or Write burst operation is executed and the bank remains active at the completion of the burst sequence. If A10 is high when the Read or Write Command is issued, then the Auto-Precharge function is enabled. During Auto-Precharge, a Read Command will execute as normal with the exception that the active bank will begin to precharge internally on the rising edge which is $\overline{\text{CAS}}$ Latency (CL) clock cycles before the end of the read burst. Auto-Precharge is also implemented for Write Commands. The precharge operation engaged by the Auto-Precharge command will not begin until the last data of the write burst sequence is properly stored in the memory array. This feature allows the precharge operation to be partially or completely hidden during burst read cycles (dependent upon $\overline{\text{CAS}}$ Latency) thus improving system performance for random data access. The RAS lockout circuit internally delays the precharge operation until the array restore operation has been completed so that the Auto-Precharge command may be issued with any read or write command.

Burst Read with Auto-Precharge

If A10 is high when a Read Command is issued, the Read with Auto-Precharge function is engaged. The DDR2 SDRAM starts an Auto-Precharge operation on the rising edge which is $(AL + BL/2)$ cycles later from the Read with AP command if $t_{\text{RAS}}(\text{min})$ and t_{RTP} are satisfied. If $t_{\text{RAS}}(\text{min})$ is not satisfied at the edge, the start point of Auto-Precharge operation will be delayed until $t_{\text{RAS}}(\text{min})$ is satisfied. If $t_{\text{RTP}}(\text{min})$ is not satisfied at the edge, the start point of Auto-Precharge operation will be delayed until $t_{\text{RTP}}(\text{min})$ is satisfied.

In case the internal precharge is pushed out by t_{RTP} , t_{RP} starts at the point where the internal precharge happens (not at the next rising clock edge after this event). So for $BL = 4$ the minimum time from Read with Auto-Precharge to the next Activate command becomes $AL + t_{\text{RTP}} + t_{\text{RP}}$. For $BL = 8$ the time from Read with Auto-Precharge to the next Activate command is $AL + 2 + t_{\text{RTP}} + t_{\text{RP}}$. Note that both parameters t_{RTP} and t_{RP} have to be rounded up to the next integer value. In any event internal precharge does not start earlier than two clocks after the last 4-bit prefetch.

A new bank active (command) may be issued to the same bank if the following two conditions are satisfied simultaneously:

- (1) The $\overline{\text{RAS}}$ precharge time (t_{RP}) has been satisfied from the clock at which the Auto-Precharge begins.
- (2) The $\overline{\text{RAS}}$ cycle time (t_{RC}) from the previous bank activation has been satisfied.

512Mb DDR2 SDRAM

Examples:

Burst Read with Auto-Precharge followed by an activation to the Same Bank (t_{RC} Limit)

$RL = 5$ ($AL = 2$, $CL = 3$), $BL = 4$, $t_{RTP} \leq 2$ clocks

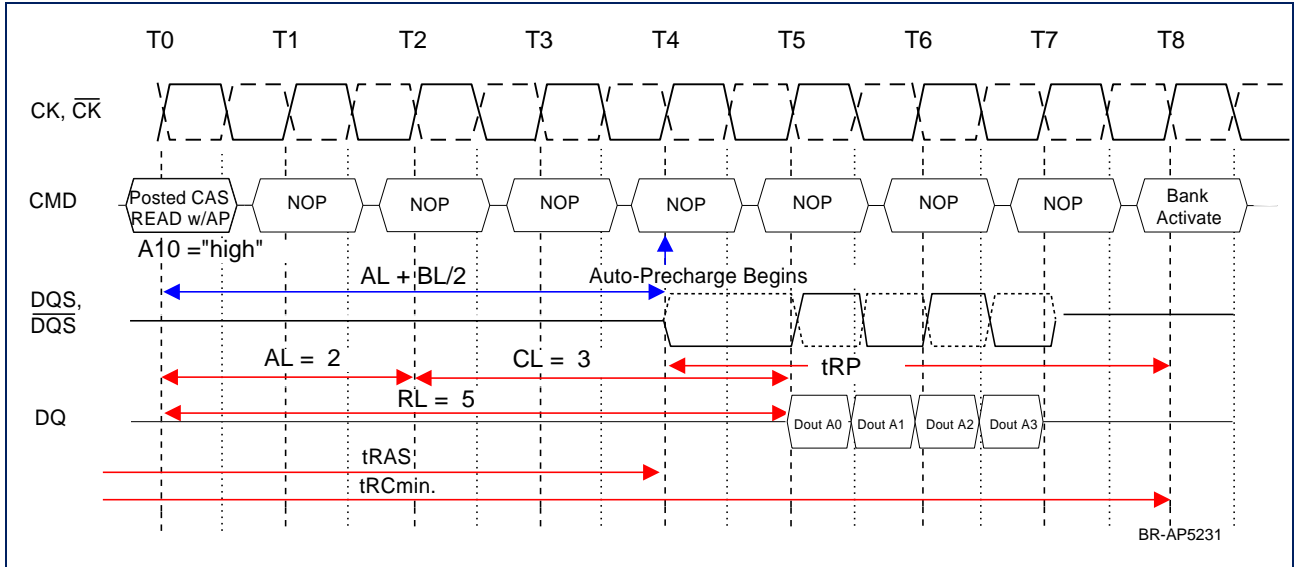

Burst Read with Auto-Precharge followed by an Activation to the Same Bank (t_{RAS} Limit):

$RL = 5$ ($AL = 2$, $CL = 3$), $BL = 4$, $t_{RTP} \leq 2$ clocks

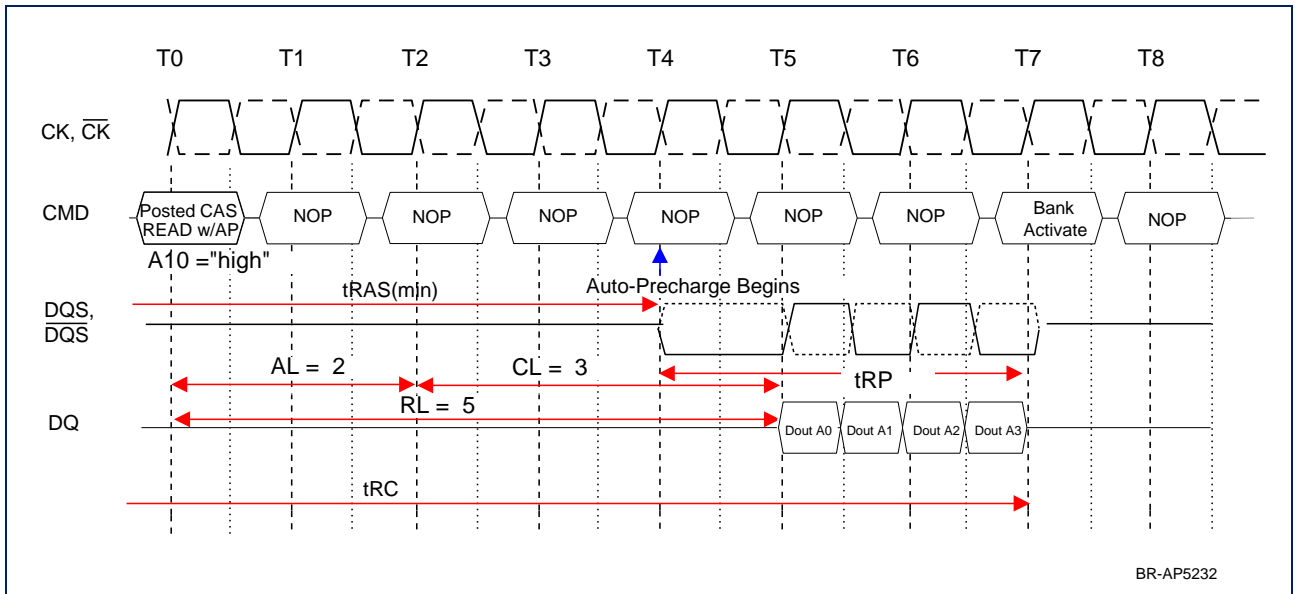

512Mb DDR2 SDRAM

Burst Read with Auto-Precharge followed by an Activation to the Same Bank:

RL = 4 (AL = 1, CL = 3), BL = 8, $t_{RTP} \leq 2$ clocks

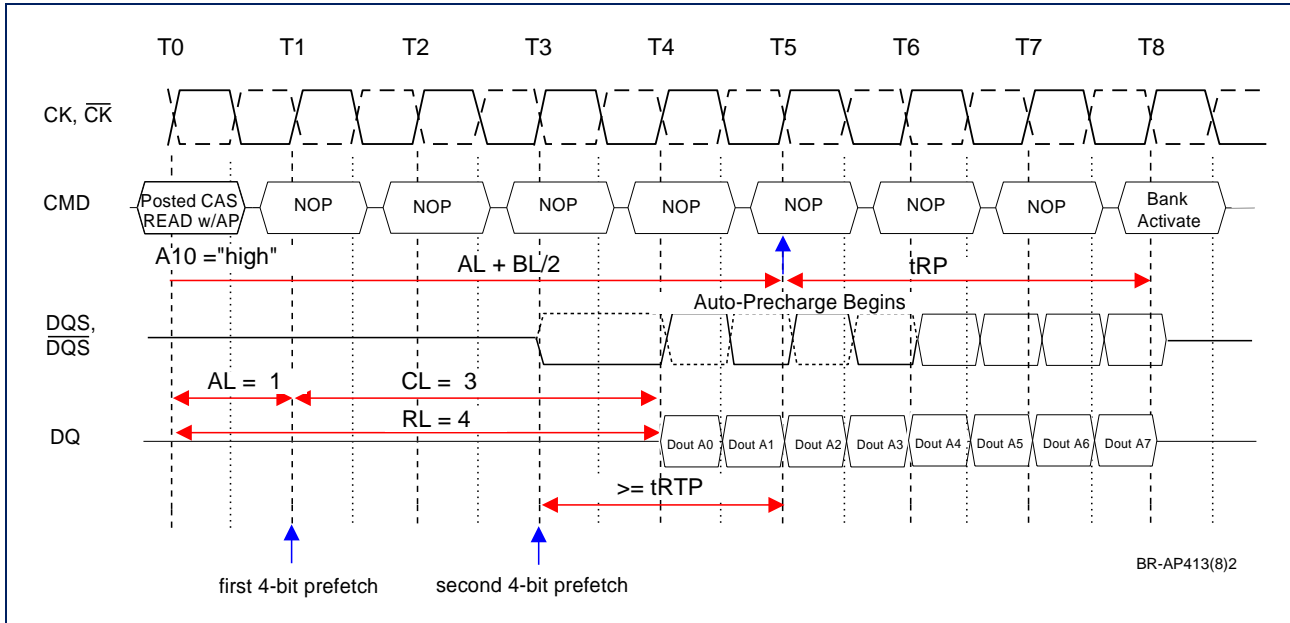

Burst Read with Auto-Precharge followed by an Activation to the Same Bank:

RL = 4 (AL = 1, CL = 3), BL = 4, $t_{RTP} > 2$ clocks

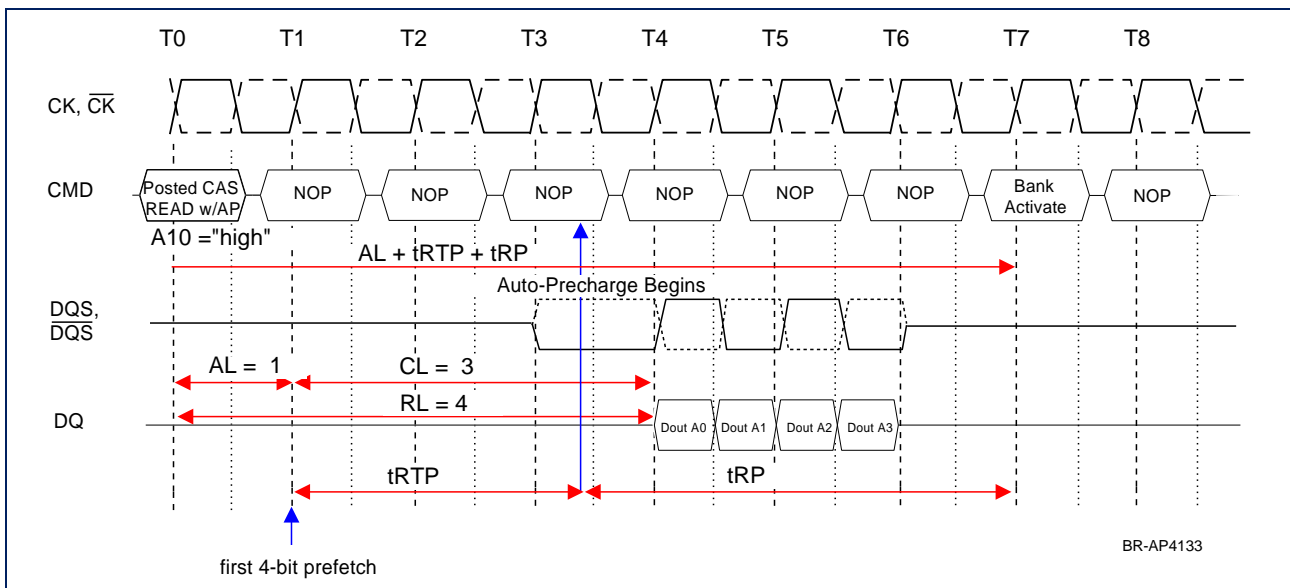

512Mb DDR2 SDRAM

Burst Write with Auto-Precharge

If A10 is high when a Write Command is issued, the Write with Auto-Precharge function is engaged. The DDR2 SDRAM automatically begins precharge operation after the completion of the write burst plus the write recovery time delay (WR), programmed in the MRS register, as long as t_{RAS} is satisfied. The bank undergoing Auto-Precharge from the completion of the write burst may be reactivated if the following two conditions are satisfied.

- (1) The last data-in to bank activate delay time ($t_{DAL} = WR + t_{RP}$) has been satisfied.
- (2) The RAS cycle time (t_{RC}) from the previous bank activation has been satisfied.

Examples:

Burst Write with Auto-Precharge (t_{RC} Limit): $WL = 2, t_{DAL} = 6$ ($WR = 3, t_{RP} = 3$), $BL = 4$

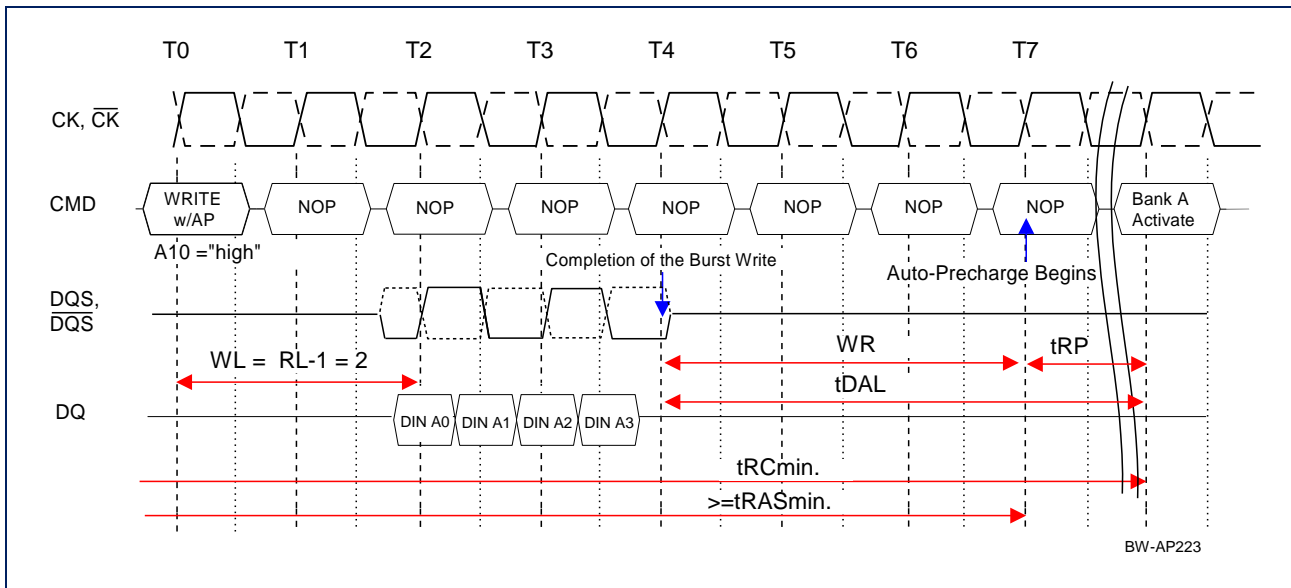

Burst Write with Auto-Precharge ($t_{WR} + t_{RP}$ Limit) : $WL = 4, t_{DAL} = 6$ ($t_{WR} = 3, t_{RP} = 3$), $BL = 4$

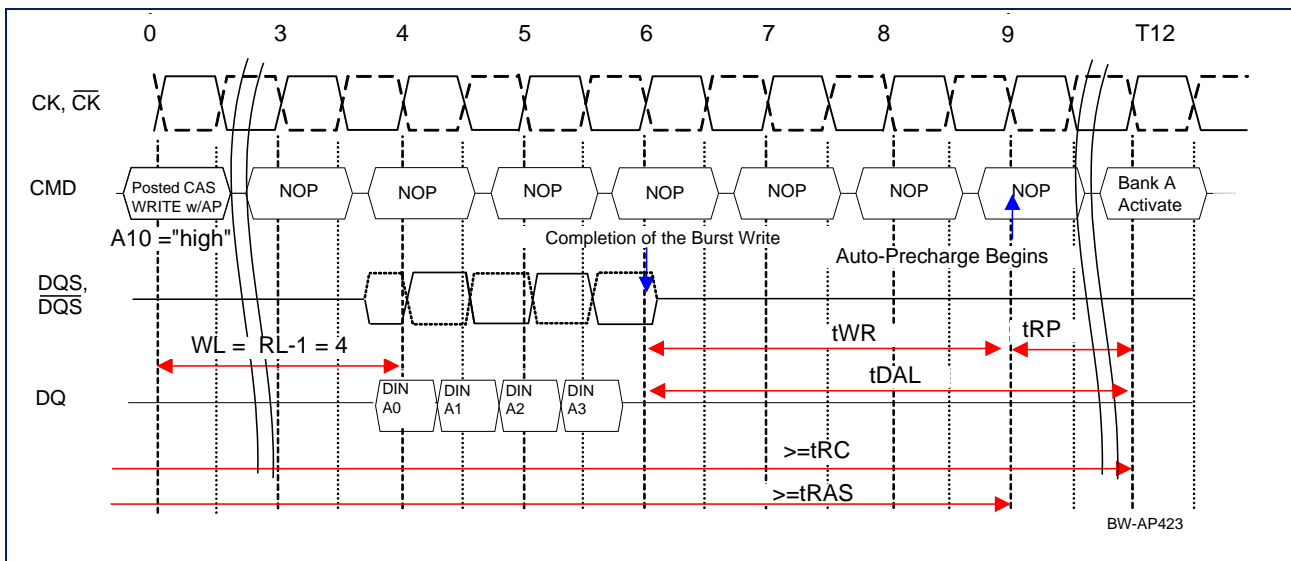

512Mb DDR2 SDRAM

Precharge & auto precharge clarification

From Command	To Command	Minimum Delay between "From command" to "to command"	Units	Note
Read	Precharge (to same Bank as Read)	$AL + BL/2 + \max(RTP, 2) - 2$	tCK	1,2
	Precharge All	$AL + BL/2 + \max(RTP, 2) - 2$	tCK	1,2
Read w/AP	Precharge (to same Bank as Read wAP)	$AL + BL/2 + \max(RTP, 2) - 2$	tCK	1,2
	Precharge AI	$AL + BL/2 + \max(RTP, 2) - 2$	tCK	1,2
Write	Precharge (to same Bank as Write)	$WL + BL/2 + tWR$	tCK	2
	Precharge AI	$WL + BL/2 + tWR$	tCK	2
Write w/AP	Precharge (to same bank as Write w/AP)	$WL + BL/2 + WR$	tCK	2
	Precharge AI	$WL + BL/2 + WR$	tCK	2
Precharge	Precharge (to same bank as Precharge)	1	tCK	2
	Precharge AI	1	tCK	2
Precharge All	Precharge	1	tCK	2
	Precharge AI	1	tCK	2

Note:

1) $RTP [cycles] = RU \{tRTP(ns)/tCK(ns)\}$, where RI stands for round up.

2) For a given bank, the precharge period should be counted from the latest precharge command, either one bank precharge or precharge all, issued to that bank. The precharge period is satisfied after tRP or tRPa depending on the latest precharge command issued to that bank.



512Mb DDR2 SDRAM

Refresh

SDRAMs require a refresh of all rows in any rolling 64 ms interval. Each refresh is generated in one of two ways: by an explicit Auto-Refresh command, or by an internally timed event in Self-Refresh mode. Dividing the number of device rows into the rolling 64 ms interval defined the average refresh interval t_{REFI} , which is a guideline to controlles for distributed refresh timing. For example, a 1Gbit DDR2 SDRAM has 8392 rows resulting in a t_{REFI} of 7.8 μ s.

Auto-Refresh Command

Auto-Refresh is used during normal operation of the DDR2 SDRAMs. This command is nonpersistent, so it must be issued each time a refresh is required. The refresh addressing is generated by the internal refresh controller. This makes the address bits "Don't Care" during an Auto-Refresh command. The DDR2 SDRAM requires Auto-Refresh cycles at an average periodic interval of t_{REFI} (maximum).

When \overline{CS} , \overline{RAS} and \overline{CAS} are held low and \overline{WE} high at the rising edge of the clock, the chip enters the Auto-Refresh mode. All banks of the SDRAM must be precharged and idle for a minimum of the precharge time (t_{RP}) before the Auto-Refresh Command can be applied. An internal address counter supplies the addresses during the refresh cycle. No control of the external address bus is required once this cycle has started.

When the refresh cycle has completed, all banks of the SDRAM will be in the precharged (idle) state. A delay between the Auto-Refresh Command and the next Activate Command or subsequent Auto-Refresh Command must be greater than or equal to the Auto-Refresh cycle time (t_{RFC}).

To allow for improved efficiency in scheduling and switching between tasks, some flexibility in the absolute refresh interval is provided. A maximum of eight Auto-Refresh commands can be posted to any given DDR2 SDRAM, meaning that the maximum absolute interval between any Auto-Refresh command and the next Auto-Refresh command is $9 * t_{REFI}$.

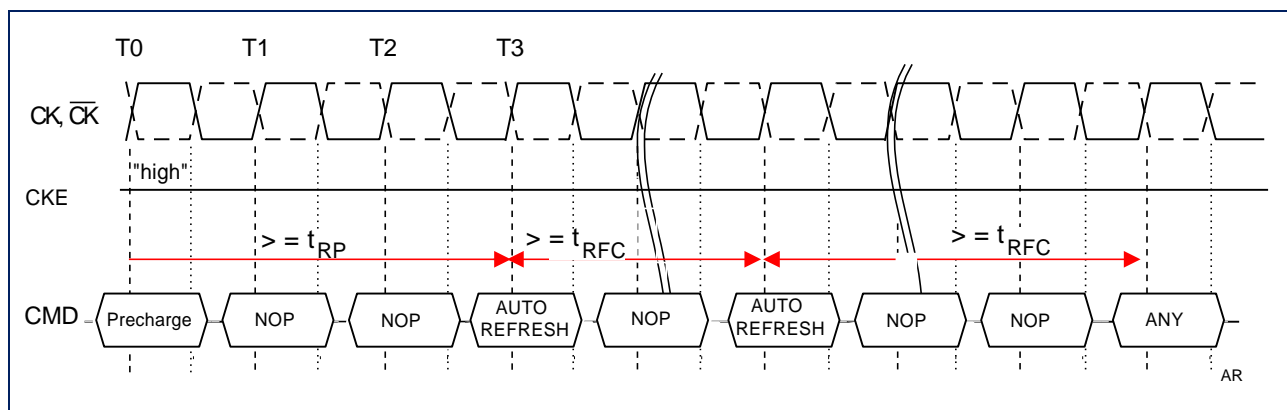

512Mb DDR2 SDRAM

Self-Refresh Command

The Self-Refresh command can be used to retain data, even if the rest of the system is powered down. When in the Self-Refresh mode, the DDR2 SDRAM retains data without external clocking.

The DDR2 SDRAM device has a built-in timer to accommodate Self-Refresh operation. The Self-Refresh Command is defined by having \overline{CS} , \overline{RAS} , \overline{CAS} and \overline{CKE} held low with \overline{WE} high at the rising edge of the clock. ODT must be turned off before issuing Self Refresh command, by either driving ODT pin low or using EMRS (1) command. Once the command is registered, CKE must be held low to keep the device in Self-Refresh mode. When the DDR2 SDRAM has entered Self-Refresh mode all of the external control signals, except CKE, are disabled. The clock is internally disabled during Self-Refresh Operation to save power. The user may change the external clock frequency or halt the external clock one clock after Self-Refresh entry is registered, however, the clock must be restarted and stable before the device can exit Self-Refresh operation. Once Self-Refresh Exit command is registered, a delay equal or longer than the t_{XSNR} or t_{XSRD} must be satisfied before a valid command can be issued to the device. CKE must remain high for the entire Self-Refresh exit period (t_{XSNR} or t_{XSRD}) for proper operation. NOP or DESELECT commands must be registered on each positive clock edge during the Self-Refresh exit interval. Since the ODT function is not supported during Self-Refresh operation, ODT has to be turned off t_{AOFD} before entering Self-Refresh Mode and can be turned on again when the t_{XSRD} timing is satisfied.

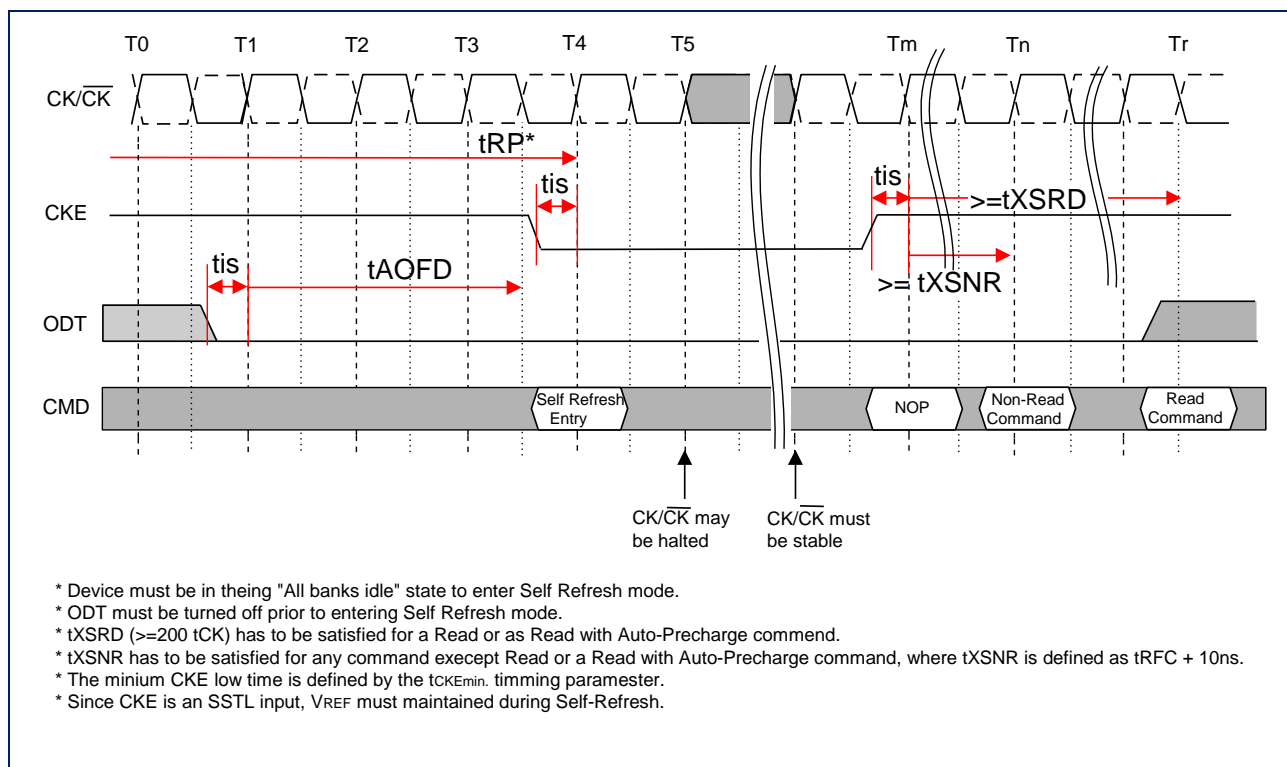

512Mb DDR2 SDRAM

Power-Down

Power-down is synchronously entered when CKE is registered low, along with NOP or Deselect command. CKE is not allowed to go low while mode register or extended mode register command time, or read or write operation is in progress. CKE is allowed to go low while any other operation such as row activation, Precharge, Auto-Precharge or Auto-Refresh is in progress, but power-down IDD specification will not be applied until finishing those operations.

The DLL should be in a locked state when power-down is entered. Otherwise DLL should be reset after exiting power-down mode for proper read operation.

If power-down occurs when all banks are precharged, this mode is referred to as *Precharge Power-down*; if power-down occurs when there is a row active in any bank, this mode is referred to as *Active Power-down*. For *Active Power-down* two different power saving modes can be selected within the MRS register, address bit A12. When A12 is set to "low" this mode is referred as "standard active power-down mode" and a fast power-down exit timing defined by the t_{XARD} timing parameter can be used. When A12 is set to "high" this mode is referred as a power saving "low power active power-down mode". This mode takes longer to exit from the power-down mode and the t_{XARDS} timing parameter has to be satisfied.

Entering power-down deactivates the input and output buffers, excluding CK, CK, ODT and CKE. Also the DLL is disabled upon entering Precharge Power-down or slow exit active power-down, but the DLL is kept enabled during fast exit active power-down. In power-down mode, CKE low and a stable clock signal must be maintained at the inputs of the DDR2 SDRAM, and all other input signals are "Don't Care". Power-down duration is limited by 9 times t_{REFI} of the device.

The power-down state is synchronously exited when CKE is registered high (along with a NOP or Deselect command). A valid, executable command can be applied with power-down exit latency, t_{XP} , t_{XARD} or t_{XARDS} , after CKE goes high. Power-down exit latencies are defined in the AC spec table of this data sheet.

Power-Down Entry

Active Power-down mode can be entered after an activate command. *Precharge Power-down mode* can be entered after a precharge, Precharge-All or internal precharge command. It is also allowed to enter power-mode after an Auto-Refresh command or MRS / EMRS(1) command when t_{MRD} is satisfied.

Active Power-down mode entry is prohibited as long as a Read Burst is in progress, meaning CKE should be kept high until the burst operation is finished. Therefore *Active Power-Down mode* entry after a Read or Read with Auto-Precharge command is allowed after $RL + BL/2$ is satisfied.

Active Power-down mode entry is prohibited as long as a Write Burst and the internal write recovery is in progress. In case of a write command, active power-down mode entry is allowed then $WL + BL/2 + t_{WTR}$ is satisfied.

In case of a write command with Auto-Precharge, Power-down mode entry is allowed after the internal precharge command has been executed, which $WL + BL/2 + WR$ is starting from the write with Auto-Precharge command. In case the DDR2 SDRAM enters the *Precharge Power-down mode*.

512Mb DDR2 SDRAM

Examples:

Active Power-Down Mode Entry and Exit after an Activate Command

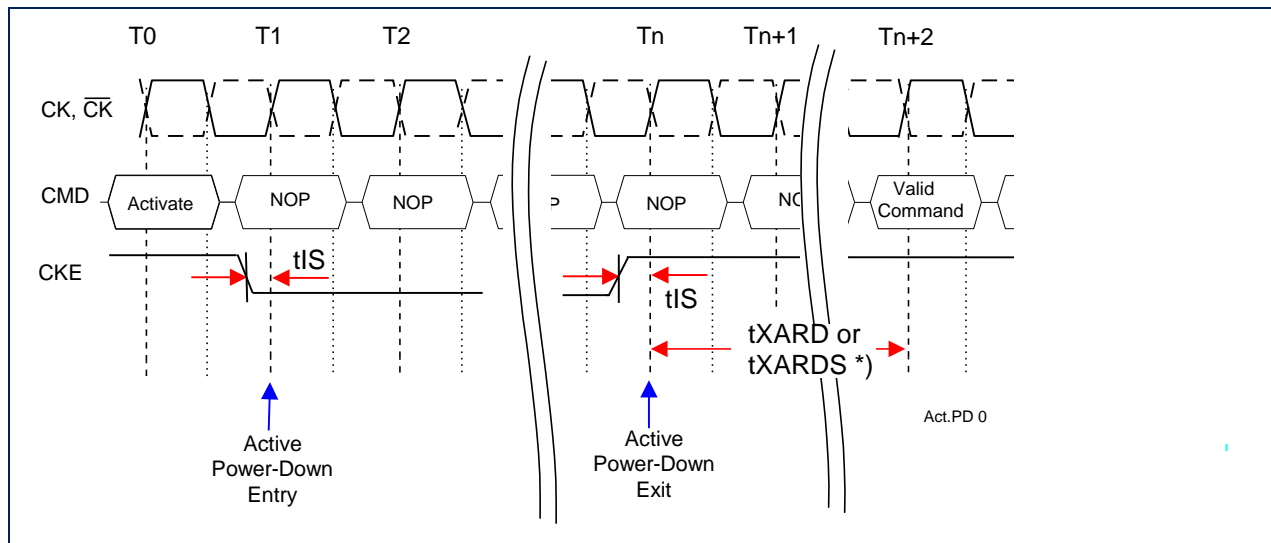

Active Power-Down Mode Entry and Exit after a Read Burst: $RL = 4$ ($AL = 1, CL = 3$), $BL = 4$

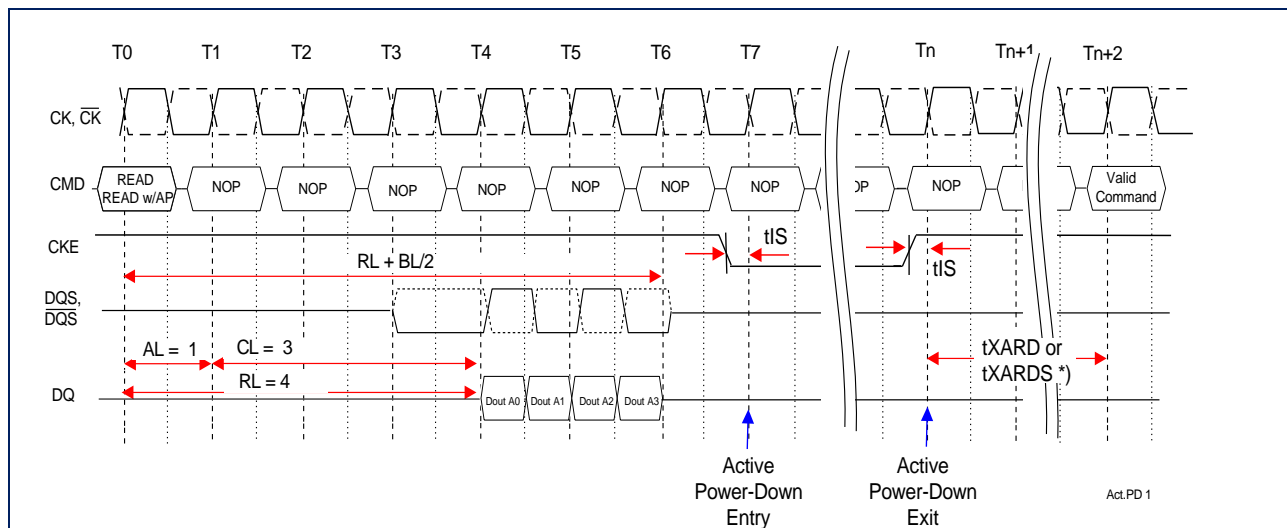

512Mb DDR2 SDRAM

Active Power-Down Mode Entry and Exit after a Write Burst: $WL = 2, tWTR = 2, BL = 4$

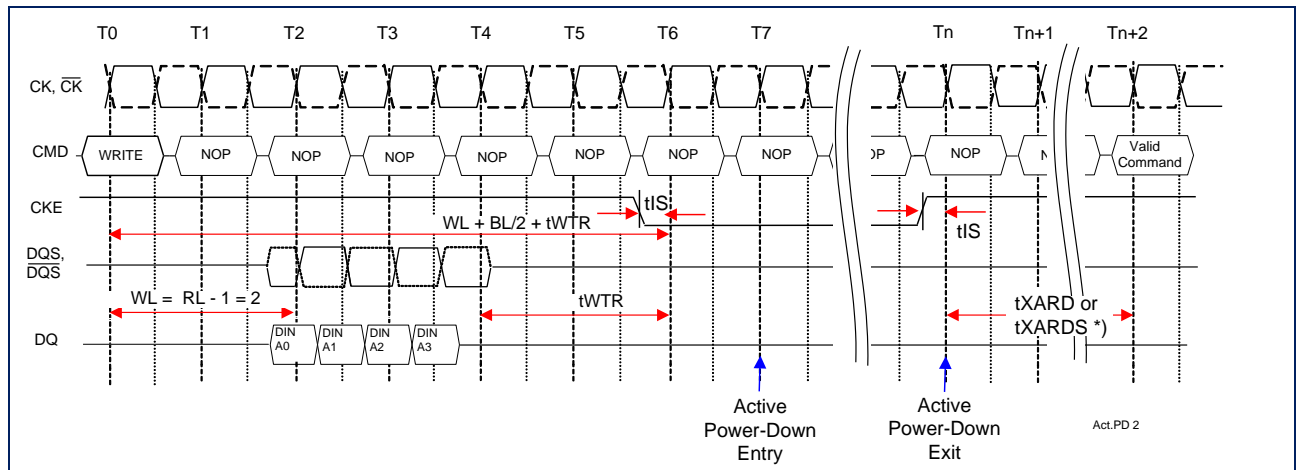

Precharge Power Down Mode Entry and Exit

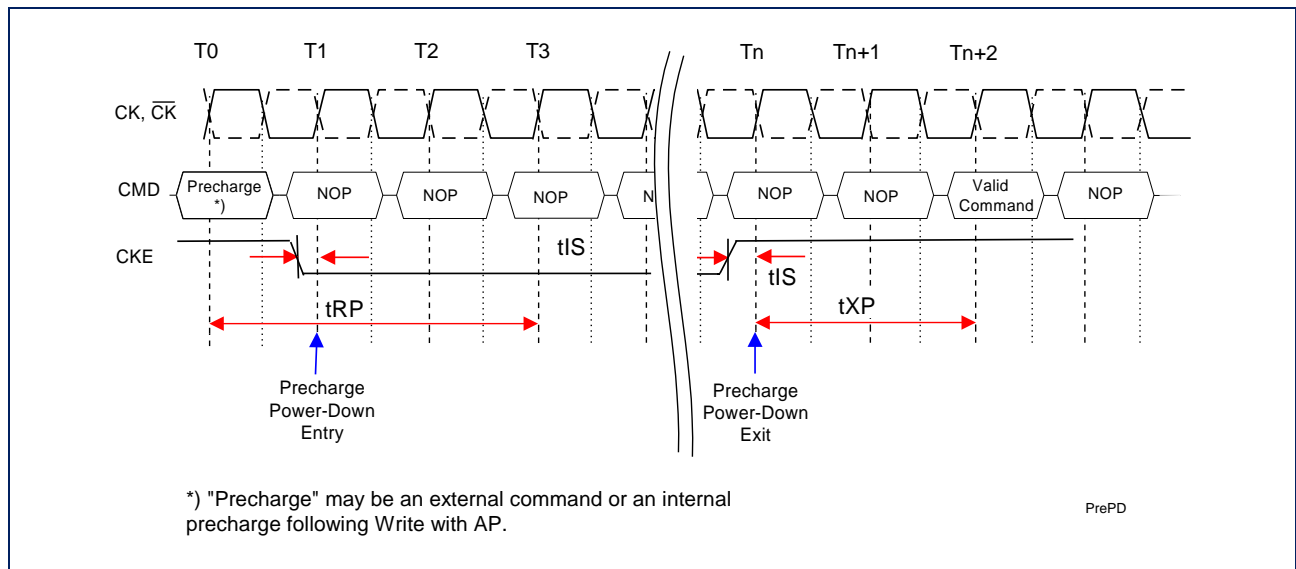

512Mb DDR2 SDRAM

No Operation Command

The No Operation Command should be used in cases when the SDRAM is in a idle or a wait state. The purpose of the No Operation Command is to prevent the SDRAM from registering any unwanted commands between operations. A No Operation Command is registered when \overline{CS} is low with \overline{RAS} , \overline{CAS} , and \overline{WE} held high at the rising edge of the clock. A No Operation Command will not terminate a previous operation that is still executing, such as a burst read or write cycle.

Deselect Command

The Deselect Command performs the same function as a No Operation Command. Deselect Command occurs when \overline{CS} is brought high, the \overline{RAS} , \overline{CAS} , and \overline{WE} signals become don't care.

Input Clock Frequency Change

During operation the DRAM input clock frequency can be changed under the following conditions:

- a) During Self-Refresh operation
- b) DRAM is in Precharge Power-down mode and ODT is completely turned off.

The DDR2-SDRAM has to be in Precharged Power-down mode and idle. ODT must be allready turned off and CKE must be at a logic "low" state. After a minimum of two clock cycles after t_{RP} and t_{AOFD} have been satisfied the input clock frequency can be changed. A stable new clock frequency has to be provided, before CKE can be changed to a "high" logic level again. After t_{XP} has been satisfied a DLL RESET command via EMRS(1) has to be issued. During the following DLL re-lock period of 200 clock cycles, ODT must remain off. After the DLL-re-lock period the DRAM is ready to operate with the new clock frequency.

Example:

Input frequency change during Precharge Power-Down mode

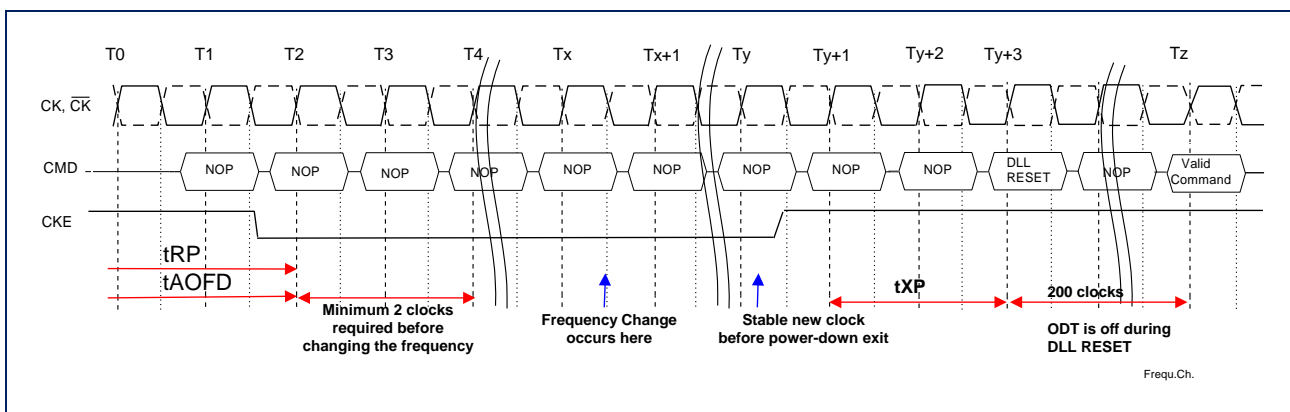

512Mb DDR2 SDRAM

Asynchronous CKE Low Event

DRAM requires CKE to be maintained “high” for all valid operations as defined in this data sheet. If CKE asynchronously drops “low” during any valid operation DRAM is not guaranteed to preserve the contents of the memory array. If this event occurs, the memory controller must satisfy a time delay (t_{delay}) before turning off the clocks. Stable clocks must exist at the input of DRAM before CKE is raised “high” again. The DRAM must be fully re-initialized as described the the initialization sequence (section 2.2.1, step 4 thru 13). DRAM is ready for normal operation after the initialization sequence. See AC timing parametric table for t_{delay} specification.

Asynchronous CKE Low Event

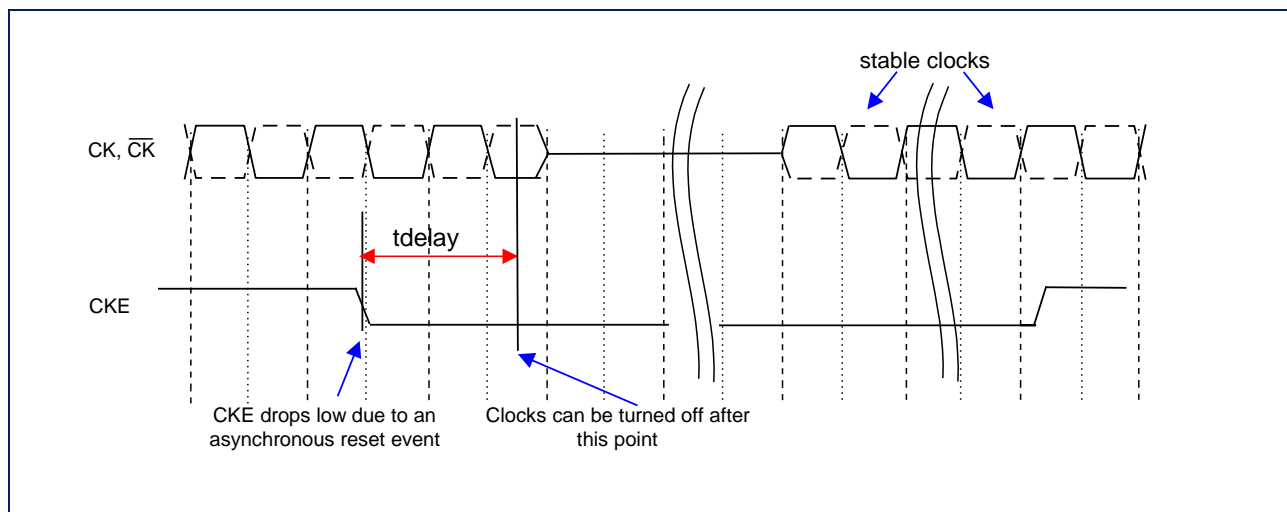

512Mb DDR2 SDRAM

Truth Table
Command Truth Table

Function	CKE		CS	RAS	CAS	WE	BA0-BA2	A13-A11	A10	A9 - A0	Notes
	Previous Cycle	Current Cycle									
(Extended) Mode Register Set	H	H	L	L	L	L	BA	OP Code			1, 2
Auto-Refresh	H	H	L	L	L	H	X	X	X	X	1
Self-Refresh Entry	H	L	L	L	L	H	X	X	X	X	1,8
Self-Refresh Exit	L	H	H	X	X	X	X	X	X	X	1,7,8
			L	H	H	H					
Single Bank Precharge	H	H	L	L	H	L	BA	X	L	X	1,2
Precharge all Banks	H	H	L	L	H	L	X	X	H	X	1
Bank Activate	H	H	L	L	H	H	BA	Row Address			1,2
Write	H	H	L	H	L	L	BA	Column	L	Column	1,2,3
Write with Auto-Precharge	H	H	L	H	L	L	BA	Column	H	Column	1,2,3
Read	H	H	L	H	L	H	BA	Column	L	Column	1,2,3
Read with Auto-Precharge	H	H	L	H	L	H	BA	Column	H	Column	1,2,3
No Operation	H	X	L	H	H	H	X	X	X	X	1
Device Deselect	H	X	H	X	X	X	X	X	X	X	1
Power Down Entry	H	L	H	X	X	X	X	X	X	X	1,4
			L	H	H	H					
Power Down Exit	L	H	H	X	X	X	X	X	X	X	1,4
			L	H	H	H					

- All DDR2 SDRAM commands are defined by states of CS, WE, RAS, CAS, and CKE at the rising edge of the clock.
- Bank addresses (BAx) determine which bank is to be operated upon. For (E) MRS BAx selects an (Extended) Mode Register.
- Burst reads or writes at BL = 4 cannot be terminated. See sections "Reads interrupted by a Read" and "Writes interrupted by a Write" inspection for details.
- The Power Down Mode does not perform any refresh operations. The duration of Power Down is therefore limited by the refresh requirements outlined.
- The state of ODT does not affect the states described in this table. The ODT function is not available during Self Refresh.
- X means "H or L (but a defined logic level)".
- Self refresh exit is asynchronous.
- Vref must be maintained during Self Refresh operation.

Clock Enable (CKE) Truth Table for Synchronous Transitions

Current State ²	CKE		Command (N) ³ \overline{RAS} , \overline{CAS} , \overline{WE} , \overline{CS}	Action (N) ³	Notes
	Previous Cycle ¹ (N-1)	Current Cycle ¹ (N)			
Power-Down	L	L	X	Maintain Power-Down	11, 13, 15
	L	H	DESELECT or NOP	Power-Down Exit	4, 8, 11, 13
Self Refresh	L	L	X	Maintain Self Refresh	11, 15, 16
	L	H	DESELECT or NOP	Self Refresh Exit	4, 5, 9, 16
Bank(s) Active	H	L	DESELECT or NOP	Active Power-Down Entry	4,8,10,11,13
All Banks Idle	H	L	DESELECT or NOP	Precharge Power-Down Entry	4,8,10,11,13
	H	L	AUTOREFRESH	Self Refresh Entry	6, 9, 11,13
Any State other than listed above	H	H	Refer to the Command Truth Table		7

1. CKE (N) is the logic state of CKE at clock edge N; CKE (N-1) was the state of CKE at the previous clock edge.
2. Current state is the state of the DDR2 SDRAM immediately prior to clock edge N.
3. Command (N) is the command registered at clock edge N, and Action (N) is a result of Command (N).
4. All states and sequences not shown are illegal or reserved unless explicitly described elsewhere in this document.
5. On Self Refresh Exit DESELECT or NOP commands must be issued on every clock edge occurring during the tXSNR period. Read commands may be issued only after tXSRD (200 clocks) is satisfied.
6. Self Refresh mode can only be entered from the All Banks Idle state.
7. Must be a legal command as defined in the Command Truth Table.
8. Valid commands for Power-Down Entry and Exit are NOP and DESELECT only.
9. Valid commands for Self Refresh Exit are NOP and DESELCT only.
10. Power-Down and Self Refresh cannot be entered while Read or Write operations, (Extended) mode Register operations, Precharge or Refresh operations are in progress. See section 2.8 "Power Down" and section 2.7.2 "Self Refresh Command" for a detailed list of restrictions.
11. Minimum CKE high time is 3 clocks, minimum CKE low time is 3 clocks.
12. The state of ODT does not affect the states described in this table. The ODT function is not available during Self Refresh.
13. The Power-Down Mode does not perform any refresh operations. The duration of Power-Down Mode is therefore limited by the refresh requirements.
14. CKE must be maintained high while the device is in OCD calibration mode.
15. "X" means "don't care (including floating around VREF)" in Self Refresh and Power Down. However DT must be driven high or low in Power Down if the ODT function is enabled (Bit A2 or A6 set to "1" in MRS(1)).
16. Vref must be maintained during Self Refresh operation

512Mb DDR2 SDRAM

Operating Conditions

Absolute Maximum DC Ratings

Symbol	Parameter	Rating	Units	Notes
V _{DD}	Voltage on VDD pin relative to VSS	-1.0 to + 2.3	V	1,3
V _{DDQ}	Voltage on VDDQ pin relative to VSS	-0.5 to + 2.3	V	1,3
V _{DDL}	Voltage on VDDL pin relative to VSS	-0.5 to + 2.3	V	1,3
V _{IN} , V _{OUT}	Voltage on any pin relative to VSS	-0.5 to + 2.3	V	1
T _{STG}	Storage Temperature	-55 to + 100	°C	1, 2

1. Stresses greater than those listed under "Absolute Maximum Ratings" may cause permanent damage to the device. This is a stress rating only and functional operation of the device at these or any other conditions above those indicated in the operational sections of this specification is not implied. Exposure to absolute maximum rating conditions for extended periods may affect reliability.

2. Storage Temperature is the case surface temperature on the center/top side of the DRAM.

3. When VDD, VDDQ, and VDDL are less than 500mV, Vref may be equal to or less than 300mV.

DRAM Component Operating Temperature Range

Symbol	Parameter	Rating	Units	Notes
T _{OPER}	Operating Temperature	0 to 95 (Standard Grade)	°C	1,2
		- 40 to 95 (Industrial Grade)		1

Note:

1. Operating temperature is the case surface temperature (T_{CASE}) on the center/top side of the DRAM.

2. At 85°C ~ 95°C T_{OPER}, it is required to set t_{RFI}=3.9μs in auto refresh mode or to set '1' for EMRS (2) bit A7 in self refresh mode.



512Mb DDR2 SDRAM

AC & DC Operating Conditions

DC Operating Conditions

Recommended DC Operating Conditions (SSTL_18)

Symbol	Parameter	Rating			Units	Notes
		Min.	Typ.	Max.		
V _{DD}	Supply Voltage	1.7	1.8	1.9	V	1
V _{DDDL}	Supply Voltage for DLL	1.7	1.8	1.9	V	5
V _{DDQ}	Supply Voltage for Output	1.7	1.8	1.9	V	1,5
V _{REF}	Input Reference Voltage	0.49 * V _{DDQ}	0.5 * V _{DDQ}	0.51 * V _{DDQ}	V	2, 3
V _{TT}	Termination Voltage	V _{REF} - 0.04	V _{REF}	V _{REF} + 0.04	V	4

- V_{DDQ} tracks with V_{DD}, V_{DDDL} tracks with V_{DD}. AC parameters are measured with V_{DD}, V_{DDQ} and V_{DDDL} tied together.
- The value of V_{REF} may be selected by the user to provide optimum noise margin in the system. Typically the value of V_{REF} is expected to be about 0.5 x V_{DDQ} of the transmitting device and V_{REF} is expected to track variations in V_{DDQ}.
- Peak to peak ac noise on V_{REF} may not exceed +/- 2% V_{REF} (dc).
- V_{TT} is not applied directly to the device. V_{TT} is a system supply for signal termination resistors is expected to be set equal to V_{REF} and must track variations in die dc level of V_{REF}.
- V_{DDQ} tracks with V_{DD}, V_{DDL} tracks with V_{DD}. AC parameters are measured with V_{DD}, V_{DDQ}, and V_{DDL} tied together.

ODT DC Electrical Characteristic

Parameter / Condition	Symbol	min.	nom.	max.	Units	Notes
Rtt eff. impedance value for EMRS(1)(A6,A2)=0,1; 75 ohm	Rtt1(eff)	60	75	90	ohms	1
Rtt eff. impedance value for EMRS(1)(A6,A2)=0,1; 150 ohm	Rtt2(eff)	120	150	180	ohms	1
Rtt eff. impedance value for EMRS(1)(A6,A2)=1,1; 50 ohm	Rtt3(eff)	40	50	60	ohms	1
Deviation of VM with respect to VDDQ / 2	delta VM	-6		6	%	2

1) Measurement Definition for Rtt(eff):

Apply V_{IHac} and V_{ILac} to test pin separately, then measure current I(V_{IHac}) and I(V_{ILac}) respectively.

$$Rtt(eff) = (V_{IHac} - V_{ILac}) / (I(V_{IHac}) - I(V_{ILac}))$$

2) Measurement Definition for VM:

Measure voltage (VM) at test pin (midpoint) with no load:

$$\text{delta VM} = ((2 * VM / VDDQ) - 1) * 100\%$$

512Mb DDR2 SDRAM

DC & AC Logic Input Levels

DDR2 SDRAM pin timing are specified for either single ended or differential mode depending on the setting of the EMRS(1) “Enable DQS” mode bit; timing advantages of differential mode are realized in system design. The method by which the DDR2 SDRAM pin timing are measured is mode dependent. In single ended mode, timing relationships are measured relative to the rising or falling edges of DQS crossing at VREF. In differential mode, these timing relationships are measured relative to the cross point of DQS and its complement, DQS. This distinction in timing methods is guaranteed by design and characterization. In single ended mode, the DQS (and RDQS) signals are internally disabled and don't care.

Single-ended DC & AC Logic Input Levels

Symbol	Parameter	DDR2-667/800/1066		Units
		Min.	Max.	
V _{IH(dc)}	DC input logic high	VREF + 0.125	VDDQ + 0.3	V
V _{IL(dc)}	DC input low	-0.3	VREF - 0.125	V
V _{IH(ac)}	AC input logic high	VREF + 0.200	VDDQ+Vpeak	V
V _{IL(ac)}	AC input low	VSSQ-Vpeak	VREF - 0.200	V

Single-ended AC Input Test Conditions

Symbol	Condition	Value	Units	Notes
V _{REF}	Input reference voltage	0.5 * V _{DDQ}	V	1, 2
V _{SWING(max)}	Input signal maximum peak to peak swing	1	V	1, 2
SLEW	Input signal minimum slew rate	1	V / ns	3, 4

1. This timing and slew rate definition is valid for all single-ended signals except tis, tih, tds, tdh.
2. Input waveform timing is referenced to the input signal crossing through the V_{REF} level applied to the device under test.
3. The input signal minimum slew rate is to be maintained over the range from V_{IL(dc)max} to V_{IH(ac)min} for rising edges and the range from V_{IH(dc)min} to V_{IL(ac)max} for falling edges as shown in the below figure.
4. AC timings are referenced with input waveforms switching from V_{IL(ac)} to V_{IH(ac)} on the positive transitions and V_{IH(ac)} to V_{IL(ac)} on the negative transitions.

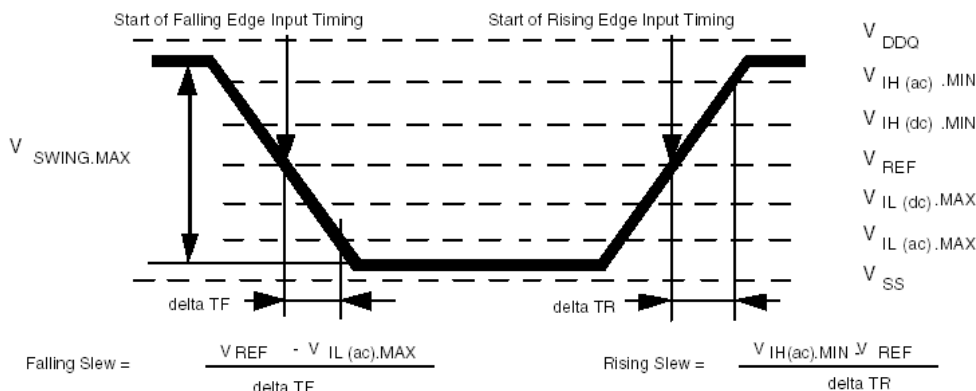

512Mb DDR2 SDRAM

Differential DC and AC Input and Output Logic Levels

Symbol	Parameter	min.	max.	Units	Notes
$V_{ID(ac)}$	AC differential input voltage	0.5	VDDQ	V	1
$V_{IX(ac)}$	AC differential cross point input voltage	$0.5 * VDDQ - 0.175$	$0.5 * VDDQ + 0.175$	V	2
$V_{OX(ac)}$	AC differential cross point output voltage	$0.5 * VDDQ - 0.125$	$0.5 * VDDQ + 0.125$	V	3

Notes:

- 1) $V_{ID(ac)}$ specifies the allowable DC execution of each input of differential pair such as CK, \overline{CK} , DQS, \overline{DQS} , LDQS, \overline{LDQS} , UDQS, and \overline{UDQS} .
- 2) $V_{IX(ac)}$ specifies the input differential voltage $I_{VTR}-V_{CPI}$ required for switching, where VTR is the true input (such as CK, DQS, LDQS, or UDQS) level and VCP is the complementary input (such as \overline{CK} , \overline{DQS} , \overline{LDQS} , or \overline{UDQS}) level. The minimum value is equal to $V_{IH(DC)} - V_{IL(DC)}$.
- 3) The typical value of $V_{OX(AC)}$ is expected to be about $0.5V_{DDQ}$ of the transmitting device and $V_{OX(AC)}$ is expected to track variations in V_{DDQ} . $V_{OX(AC)}$ indicates the voltage at which differential signals must cross.

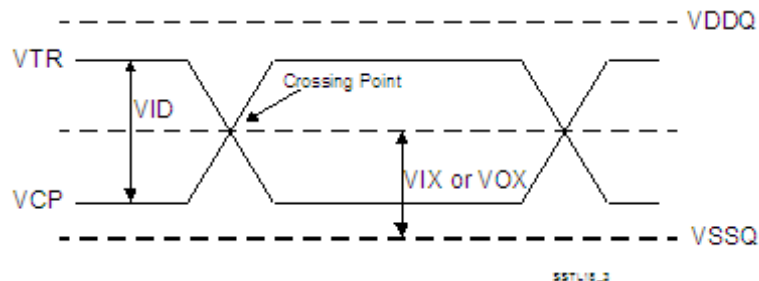

512Mb DDR2 SDRAM

Output Buffer Levels

Output AC Test Conditions

Symbol	Parameter	SSTL-18 Class II	Units	Notes
V_{OTR}	Output Timing Measurement Reference Level	$0.5 * V_{DDQ}$	V	1

1. The V_{DDQ} of the device under test is referenced.

Output DC Current Drive

Symbol	Parameter	SSTL-18	Units	Notes
$I_{OH(dc)}$	Output Minimum Source DC Current, nominal	-13.4	mA	1, 3, 4
$I_{OL(dc)}$	Output Minimum Sink DC Current, nominal	13.4	mA	2, 3, 4

1. $V_{DDQ} = 1.7$ V; $V_{OUT} = 1.42$ V. $(V_{OUT} - V_{DDQ}) / I_{OH}$ must be less than 21 ohm for values of V_{OUT} between V_{DDQ} and $V_{DDQ} - 280$ mV.
2. $V_{DDQ} = 1.7$ V; $V_{OUT} = -280$ mV. V_{OUT} / I_{OL} must be less than 21 ohm for values of V_{OUT} between 0V and 280 mV.
3. The dc value of V_{REF} applied to the receiving device is set to V_{TT}
4. The values of $I_{OH(dc)}$ and $I_{OL(dc)}$ are based on the conditions given in note 1 and 2. They are used to test drive current capability to ensure $V_{IHmin.}$ plus a noise margin and $V_{ILmax.}$ minus a noise margin are delivered to an SSTL_18 receiver. The actual current values are derived by shifting the desired driver operating points along 21 ohm load line to define a convenient current for measurement.

OCD Default Setting Table

Symbol	Description	Min.	Nominal	Max.	Unit	Notes
-	Pull-up / Pull down mismatch	0	-	4	Ohms	6
-	Output Impedance step size for OCD calibration	0	-	1.5	Ohms	1,2,3
S_{OUT}	Output Slew Rate	1.5	-	5	V / ns	1,4,5,7,8

1) Absolute Specification: T_{OPEN} ; $V_{DDQ} = 1.8V \pm 0.1V$; $V_{DD} = 1.8V \pm 0.1V$.
2) Impedance measurement condition for output source dc current: $V_{DDQ} = 1.7V$, $V_{OUT} = 1420$ mV; $(V_{OUT} - V_{DDQ}) / I_{OH}$ must be less than 23.4 ohms for values of V_{OUT} between V_{DDQ} and $V_{DDQ} - 280$ mV. Impedance measurement condition for output sink dc current: $V_{DDQ} = 1.7$ V; $V_{OUT} = -280$ mV; V_{OUT} / I_{OL} must be less than 23.4 ohms for values of V_{OUT} between 0V and 280 mV.
3) Mismatch is absolute value between pull-up and pull-down; both are measured at same temperature and voltage.
4) Slew rates measured from $V_{IL(AC)}$ to $V_{IH(AC)}$ with the load specified in Section 8.2.
5) The absolute value of the slew rate as measured from DC to DC is equal to or greater than the slew rate as measured from AC to AC. This is guaranteed by design and characterization.
6) This represents the step size when the OCD is near 18 ohms at nominal conditions across all process parameters and represents only the DRAM uncertainty. A 0 Ohm value (no calibration) can only be achieved if the OCD impedance is 18 ± 0.75 ohms under nominal conditions.
7) DRAM output slew rate specification applies to 533MT/s, 667MT/s, and 800MT/s speed pin.
8) Timing skew due to DRAM output slew rate mis-match between DQS / \overline{DQS} and associated DQ's is included in t_{DQSQ} and t_{QHS} specification.

512Mb DDR2 SDRAM

Default Output V-I Characteristics

DDR2 SDRAM output driver characteristics are defined for full strength default operation as selected by the EMRS (1) bits A7~A9 = '111'. The driver characteristics evaluation conditions are: a) Nominal Default 25°C (Tcase), VDDQ=1.8V, typical process. b) Minimum T_{OPER(max)}, VDDQ=1.7V, slow-slow process. c) Maximum 0°C (Tcase), VDDQ=1.9V, fast-fast process

512Mb DDR2 SDRAM

Full Strength Default Pullup Driver Characteristics

Voltage (V)	Minimum (23.4 Ohms)	Nomal Default low (18 Ohms)	Nomal Default high (18 Ohms)	Maximum (12.6 Ohms)
0.0	0.00	0.00	0.00	0.00
0.1	-4.30	-5.65	-5.90	-7.95
0.2	-8.60	-11.30	-11.80	-15.90
0.3	-12.90	-16.50	-16.80	-23.85
0.4	-16.90	-21.20	-22.10	-31.80
0.5	-20.05	-25.00	-27.60	-39.75
0.6	-22.10	-28.30	-32.40	-47.70
0.7	-23.27	-30.90	-36.90	-55.55
0.8	-24.10	-33.00	-40.90	-62.95
0.9	-24.73	-34.50	-44.60	-69.55
1.0	-25.23	-35.50	-47.70	-75.35
1.1	-25.65	-36.10	-50.40	-80.35
1.2	-26.02	-36.60	-52.60	-84.55
1.3	-26.35	-36.90	-54.20	-87.95
1.4	-26.65	-37.10	-55.90	-90.70
1.5	-26.93	-37.40	-57.10	-93.00
1.6	-27.20	-37.60	-58.40	-95.05
1.7	-27.46	-37.70	-59.60	-97.05
1.8	-	-37.90	-60.90	-99.05
1.9	-	-	-	-101.05

The driver characteristics evaluation conditions are:
 Nominal Default 25°C (Tcase) , VDDQ = 1.8 V, typical process
 Minimum Toper(max.), VDDQ = 1.7V, slow-slow process
 Maximum 0 °C (Tcase). VDDQ = 1.9 V, fast-fast process

512Mb DDR2 SDRAM

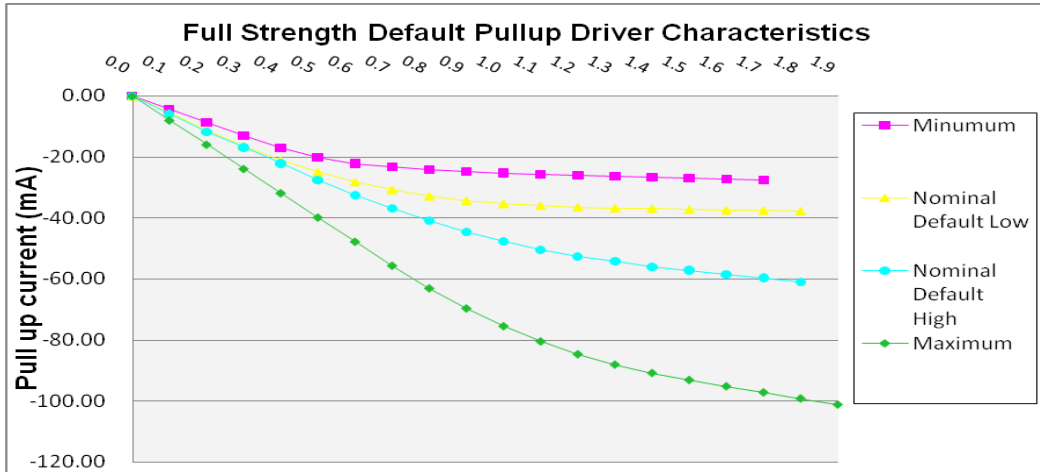

512Mb DDR2 SDRAM

Full Strength Default Pulldown Driver Characteristics

Voltage (V)	Minimum (23.4 Ohms)	Nomal Default low (18 Ohms)	Nomal Default high (18 Ohms)	Maximum (12.6 Ohms)
0.0	0.00	0.00	0.00	0.00
0.1	4.30	5.65	5.90	7.95
0.2	8.60	11.30	11.80	15.90
0.3	12.90	16.50	16.80	23.85
0.4	16.90	21.20	22.10	31.80
0.5	20.05	25.00	27.60	39.75
0.6	22.10	28.30	32.40	47.70
0.7	23.27	30.90	36.90	55.55
0.8	24.10	33.00	40.90	62.95
0.9	24.73	34.50	44.60	69.55
1.0	25.23	35.50	47.70	75.35
1.1	25.65	36.10	50.40	80.35
1.2	26.02	36.60	52.60	84.55
1.3	26.35	36.90	54.20	87.95
1.4	26.65	37.10	55.90	90.70
1.5	26.93	37.40	57.10	93.00
1.6	27.20	37.60	58.40	95.05
1.7	27.46	37.70	59.60	97.05
1.8	-	37.90	60.90	99.05
1.9	-	-	-	101.05

The driver characteristics evaluation conditions are:
 Nominal Default 25°C (Tcase) , VDDQ = 1.8 V, typical process
 Minimum Toper(max.), VDDQ = 1.7V, slow-slow process
 Maximum 0 °C (Tcase). VDDQ = 1.9 V, fast-fast process

512Mb DDR2 SDRAM

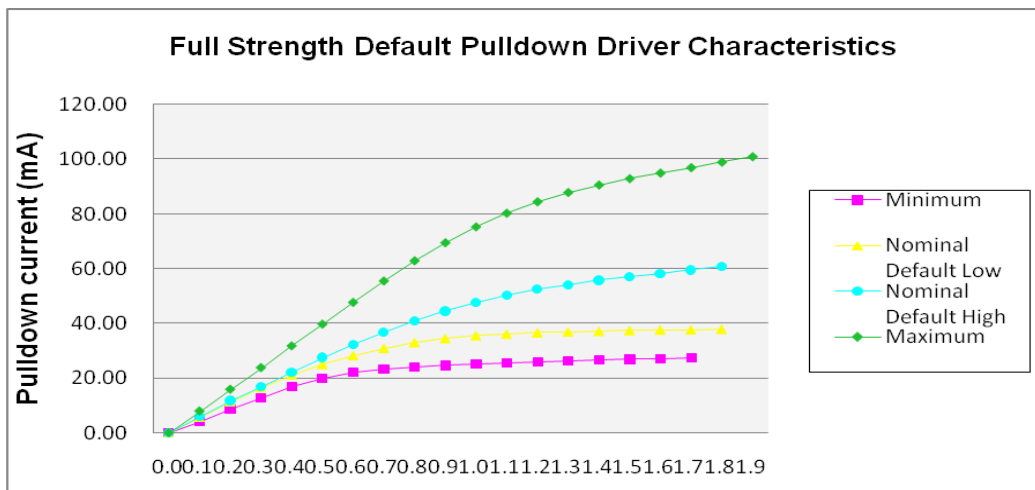

Calibrated Output Driver V-I Characteristics

DDR2 SDRAM output driver characteristics are defined for full strength calibrated operation as selected by the procedure outlined in the Off-Chip Driver (OCD) Impedance Adjustment. The following tables show the data in tabular format suitable for input into simulation tools. The nominal points represent a device at exactly 18 ohms. The nominal low and nominal high values represent the range that can be achieved with a maximum 1.5 ohms step size with no calibration error at the exact nominal conditions only (i.e. perfect calibration procedure, 1.5 ohm maximum step size guaranteed by specification). Real system calibration error needs to be added to these values. It must be understood that these V-I curves are represented here or in supplier IBIS models need to be adjusted to a wider range as a result of any system calibration error. Since this a system specific phenomena, it cannot be quantified here. the values in the calibrated tables represent just the DRAM portion of uncertainty while looking at one DQ only. If the calibration procedure is used, it is possible to cause the device to operate outside the bounds of the default device characteristics tables and figure. in such a situation, the timing parameters in the specification cannot be guaranteed. It is solely up to the system application to ensure that the device is calibrated between the minimum and maximum default values at all times. If this can't be guaranteed by the system calibration procedure, re-calibration policy and uncertainty with DQ to DQ variation, it is recommend that only the default values to be used. The nominal maximum ad minimum values represent the change in impedance from nominal low and high as a result of voltage and temperature change from the nominal condition to the maximum and minimum conditions. If calibrated at an extreme condition, the amount of variation could be as much as from the nominal minimum to the nominal maximum or vice versa.



512Mb DDR2 SDRAM

Full Strength Calibrated Pulldown Driver Characteristics

Voltage (V)	Nominal Minimum (21 Ohms)	Normal Low (18.75 Ohms)	Nominal (18 ohms)	Normal High (17.25 Ohms)	Nominal Maximum (15 Ohms)
0.2	9.5	10.7	11.5	11.8	13.3
0.3	14.3	16.0	16.6	17.4	20.0
0.4	18.7	21.0	21.6	23.0	27.0

The driver characteristics evaluation conditions are:
 Nominal 25°C (Tcase) , VDDQ = 1.8 V, typical process
 Nominal Low and Nominal High 25°C (Tcase), VDDQ = 1.8V, any process
 Nominal Minimum Toper(max), VDDQ = 1.7 V, any process
 Nominal Maximum 0°C (Tcase), VDDQ = 1.9 V, any process

Full Strength Calibrated Pullup Driver Characteristics

Voltage (V)	Nominal Minimum (21 Ohms)	Normal Low (18.75 Ohms)	Nominal (18 ohms)	Normal High (17.25 Ohms)	Nominal Maximum (15 Ohms)
0.2	-9.5	-10.7	-11.4	-11.8	-13.3
0.3	-14.3	-16.0	-16.6	-17.4	-20.0
0.4	-18.7	-21.0	-21.6	-23.0	-27.0

The driver characteristics evaluation conditions are:
 Nominal 25°C (Tcase) , VDDQ = 1.8 V, typical process
 Nominal Low and Nominal High 25°C (Tcase), VDDQ = 1.8V, any process
 Nominal Minimum Toper(max), VDDQ = 1.7 V, any process
 Nominal Maximum 0°C (Tcase), VDDQ = 1.9 V, any process

512Mb DDR2 SDRAM

Symbol	Parameter	-3C/3CI		-AC/ACI		-BE		-BD		Units
		min.	max.	min.	max.	min.	max.	min.	max.	
CCK	Input capacitance, CK and \overline{CK}	1.0	2.0	1.0	2.0	1.0	2.0	1.0	2.0	pF
CDCK	Input capacitance delta, CK and \overline{CK}	-	0.25	-	0.25	-	0.25	-	0.25	pF
CI	Input capacitance, all other input-only pins	1.0	2.0	1.0	1.75	1.0	1.75	1.0	1.75	pF
CDI	Input capacitance delta, all other input-only pins	-	0.25	-	0.25	-	0.25	-	0.25	pF
CIO	Input/output capacitance, DQ, DM, DQS, \overline{DQS}	2.5	3.5	2.5	3.5	2.5	3.5	2.5	3.5	pF
CDIO	Input/output capacitance delta, DQ, DM, DQS, \overline{DQS}	-	0.5	-	0.5	-	0.5	-	0.5	pF

512Mb DDR2 SDRAM

Power & Ground Clamp V-I Characteristics

Power and Ground clamps are provided on address (A0~A13, BA0, BA1, BA2), $\overline{\text{RAS}}$, $\overline{\text{CAS}}$, $\overline{\text{CS}}$, WE, CKE, and ODT pins. The V-I characteristics for pins with clamps is shown in the following table

Voltage across clamp (V)	Minimum Power Clamp Current (mA)	Minimum Ground Clamp Current (mA)
0.0	0.0	0.0
0.1	0.0	0.0
0.2	0.0	0.0
0.3	0.0	0.0
0.4	0.0	0.0
0.5	0.0	0.0
0.6	0.0	0.0
0.7	0.0	0.0
0.8	0.1	0.1
0.9	1.0	1.0
1.0	2.5	2.5
1.1	4.7	4.7
1.2	6.8	6.8
1.3	9.1	9.1
1.4	11.0	11.0
1.5	13.5	13.5
1.6	16.0	16.0
1.7	18.2	18.2
1.8	21.0	21.0

512Mb DDR2 SDRAM

IDD Specifications and Measurement Conditions

IDD Specifications

(VDDQ = 1.8V ± 0.1V; VDD = 1.8V ± 0.1V)

Symbol	Parameter/Condition	I/O	-3C/-3CI	-AC/-ACI	-BE	-BD	Unit	Notes	
IDD0	Operating Current	x8	60	65	75	75	mA	1,2	
		x16	65	70	80	80			
IDD1	Operating Current	x8	75	85	100	100	mA	1,2	
		x16	90	110	130	130			
IDD2P	Precharge Power-Down Current	All	6	6	6	6	mA	1,2	
IDD2N	Precharge Standby Current	All	40	45	50	50	mA	1,2	
IDD2Q	Precharge Quiet Standby Current	All	45	50	55	55	mA	1,2	
IDD3P	Active Power-Down Standby Current	MRS(12)=0	All	25	30	35	35	mA	1,2
		MRS(12)=1	All	11	11	11	11	mA	1,2
IDD3N	Active Standby Current	x8	35	45	55	55	mA	1,2	
		x16	55	60	70	70			
IDD4R	Operating Current Burst Read	/x8	100	115	130	130	mA	1,2	
		x16	130	160	180	180			
IDD4W	Operating Current Burst Write	x8	100	120	155	155	mA	1,2	
		x16	130	190	250	250			
IDD5	Auto-Refresh Current	/x8	140	155	180	180	mA	1,2	
		x16	190	200	210	210			
IDD6	Self-Refresh Current for standard products	All	6	6	6	6	mA	1,2	
IDD7	Operating Current	/x8	200	220	250	250	mA	1,2	
		x16	230	260	320	320			



512Mb DDR2 SDRAM

IDD Measurement Conditions

(VDDQ = 1.8V ± 0.1V; VDD = 1.8V ± 0.1V)

IDD1	Operating Current - One bank Active - Read - Precharge IOUT = 0 mA; BL = 4, tCK = tCKmin, tRC = tRCmin; tRAS = tRASmin; tRCD = tRCDmin, CL = CLmin.;AL = 0; CKE is HIGH, \overline{CS} is HIGH between valid commands;Address bus inputs are SWITCHING,Data bus inputs are SWITCHING;
IDD2P	Precharge Power-Down Current: All banks idle; CKE is LOW; tCK = tCKmin.; Other control and address inputs are STABLE, Data Bus inputs are FLOATING.
IDD2N	Precharge Standby Current: All banks idle; \overline{CS} is HIGH; CKE is HIGH; tCK = tCKmin.; Other control and address bus inputs are SWITCHING; Data bus inputs are SWITCHING.
IDD2Q	Precharge Quiet Standby Current:All banks idle; \overline{CS} is HIGH; CKE is HIGH; tCK = tCKmin.; Other control and address bus inputs are STABLE; Data bus inputs are FLOATING.
IDD3P(0)	Active Power-Down Current: All banks open; tCK = tCKmin.;CKE is LOW; Other control and address inputs are STABLE; Data Bus inputs are FLOATING. MRS A12 bit is set to "0"(Fast Power-down Exit);
IDD3P(1)	Active Power-Down Current: All banks open; tCK = tCKmin.;CKE is LOW; Other control and address inputs are STABLE; Data Bus inputs are FLOATING. MRS A12 bit is set to "1"(Slow Power-down Exit);
IDD3N	Active Standby Current: All banks open; tCK = tCKmin.; tRAS = tRASmax.; tRP = tRPmin., CKE is HIGH; \overline{CS} is HIGH between valid commands; Other control and address inputs are SWITCHING; Data Bus inputs are SWITCHING.
IDD4R	Operating Current - Burst Read: All banks open; Continuous burst reads; BL = 4; AL = 0, CL = CLmin.; tCK = tCKmin.; tRAS = tRASmax., tRP = tRPmin., CKE is HIGH, \overline{CS} is HIGH between valid commands; Address inputs are SWITCHING; Data bus inputs are SWITCHING; IOUT = 0mA.
IDD4W	Operating Current - Burst Write: All banks open; Continuous burst writes; BL = 4; AL = 0, CL = CLmin.; tCK = tCKmin.; tRAS = tRASmax., tRP = tRPmin.;CKE is HIGH, \overline{CS} is HIGH between valid commands; Address inputs are SWITCHING; Data Bus inputs are SWITCHING.
IDD5	Auto-Refresh Current: tRC = tRFC(min) which is 8 * tCK for DDR200 at tCK = 10 ns, 10 * tCK for DDR266 at tCK = 7.5 ns; 12 * tCK for DDR333 at tCK = 6ns; 14 * tCK for DDR400 at tCK = 5ns
IDD6	Self-Refresh Current: CKE <= 0.2V; external clock off, CK and \overline{CK} at 0V; Other control and address inputs are FLOATING; Data Bus inputs are FLOATING.
IDD7	Operating Bank Interleave Read Current: 1. All bank interleaving reads; IOUT = 0 mA, BL =4, CL = CLmin., AL = tRCDmin. - 1*tCK; tCK = tCKmin., tRC = tRCmin.; tRRD = tRRDmin; tRCD = 1*tCK, CKE = HIGH, CS is HIGH between valid commands; Address bus inputs are STABLE during DESELECTS. 2. Timing pattern: - DDR2 -667 5-5-5: A0 RA0 D D A1 RA1 D D A2 RA2 D D A3 RA3 D D D D D D - DDR2 -800 5-5-5: A0 RA0 D D A1 RA1 D D A2 RA2 D D A3 RA3 D D D D D D D D - DDR2 -1066 6-6-6: A0 RA0 D D D A1 RA1 D D D A2 RA2 D D D A3 RA3 D D D D D D D D 3. Legend : A=Activate, RA=Read with Auto-Precharge, D=DESELECT
<p>1. IDD specifications are tested after the device is properly initialized.</p> <p>2. IDD parameter are specified with ODT disabled.</p> <p>3. Data Bus consists of DQ, DM, DQS, DQS, RDQS, RDQS, LDQS, LDQS, UDQS and UDQS.</p> <p>4. Definitions for IDD :</p> <p>LOW is defined as VIN <= VILAC(max.); HIGH is defined as VIN >= VIHAC(min.);</p> <p>STABLE is defined as inputs are stable at a HIGH or LOW level</p> <p>FLOATING is defined as inputs are VREF = VDDQ / 2</p> <p>SWITCHING is defined as:</p> <p>Inputs are changing between HIGH and LOW every other clock (once per two clocks) for adress and control signals, and</p> <p>inputs changing between HIGH and LOW every other clock (once per two clocks) for DQ signals not including mask or stobes</p> <p>5. Timing parameter minimum and maximum values for IDD current measurements are defined in the following table.</p>	

512Mb DDR2 SDRAM

IDD Measurement Conditions (cont'd)

For testing the IDD parameters, the following timing parameters are used:

Parameter	Symble	-3C/-3CI	-AC/-ACI	-BE	-BD	Units
Latency	CL	5	5	7	6	tCK(avg)
Clock Cycle Time	tCK	3	2.5	1.875	1.875	ns
Active to Read or Write delay	tRCD	15	12.5	13.125	11.25	ns
Active to Active / Auto-Refresh command period	tRC	60	57.5	58.125	56.25	ns
Active bank A to Active bank B command delay	x8	tRRD	7.5	7.5	7.5	ns
	x16		10	10	10	
Active to Precharge Command	tRASmin	40	40	40	40	ns
	tRASmax	70000	70000	70000	70000	
Precharge Command Period	tRP	15	12.5	13.125	11.25	ns

Refresh parameters

Parameter	Symbol	Component Type	512Mb	Unit	
Auto-Refresh to Active / Auto-Refresh command period	tRFC	All	105	ns	
Average periodic Refresh interval	tREFI	Standard Grade	(0°C ≤ Tcase ≤ 85°C)	7.8	μs
			(85°C ≤ Tcase ≤ 95°C)	3.9	
		Industry Grade	(-40°C ≤ Tcase ≤ 95°C)	7.8	μs

512Mb DDR2 SDRAM

Electrical Characteristics & AC Timing - Absolute Specification

Timing Parameter by Speed Grade

(VDDQ = 1.8V ± 0.1V; V_{DD} = 1.8V ± 0.1V)

Symbol	Parameter	-3C/-3CI		-AC/-ACI		-BE		-BD		Units
		Min.	Max.	Min.	Max.	Min.	Max.	Min.	Max.	
tCK(avg)	Clock cycle time, CL=x, (Average)	3000	8000	2500	8000	1875	8000	1875	8000	ps
tCH(avg)	CK, $\overline{\text{CK}}$ high-level width (Average)	0.48	0.52	0.48	0.52	0.48	0.52	0.48	0.52	tCK(avg)
tCL(avg)	CK, $\overline{\text{CK}}$ low-level width (Average)	0.48	0.52	0.48	0.52	0.48	0.52	0.48	0.52	tCK(avg)
WL	Write command to DQS associated clock edge	RL-1								nCK
tDQSS	DQS latching rising transitions to associated clock edges	-0.25	0.25	-0.25	0.25	-0.25	0.25	-0.25	0.25	tCK(avg)
tDSS	DQS falling edge to CK setup time	0.2	-	0.2	-	0.2	-	0.2	-	tCK(avg)
tDSH	DQS falling edge hold time from CK	0.2	-	0.2	-	0.2	-	0.2	-	tCK(avg)
tDQSL,H	DQS input low (high) pulse width	0.35	-	0.35	-	0.35	-	0.35	-	tCK(avg)
tWPRE	Write preamble	0.35	-	0.35	-	0.35	-	0.35	-	tCK(avg)
tWPST	Write postamble	0.4	0.6	0.4	0.6	0.4	0.6	0.4	0.6	tCK(avg)
tIS	Address and control input setup time	200	-	175	-	125	-	125	-	ps
tIH	Address and control input hold time	275	-	250	-	200	-	200	-	ps
tIPW	Address and control input pulse width (each input)	0.6	-	0.6	-	0.6	-	0.6	-	tCK(avg)
tDS	DQ and DM input setup time									differential
		100	-	50	-	0	-	0	-	ps
tDH	DQ and DM input hold time									differential
		175	-	125	-	75	-	75	-	ps

512Mb DDR2 SDRAM

Symbol	Parameter	-3C/-3CI		-AC/-ACI		-BE		-BD		Units
		Min.	Max.	Min.	Max.	Min.	Max.	Min.	Max.	
tDIPW	DQ and DM input pulse width (each input)	0.35	-	0.35	-	0.35	-	0.35	-	tCK(avg)
tAC	DQ output access time from CK / $\overline{\text{CK}}$	-450	450	-400	400	-350	350	-350	350	ps
tDQSCK	DQS output access time from CK / $\overline{\text{CK}}$	-400	400	-350	350	-325	325	-325	325	ps
tHZ	Data-out high-impedance time from CK / $\overline{\text{CK}}$	-	tAC,max	-	tAC,max	-	tAC,max	-	tAC,max	ps
tLZ(DQS)	DQS($\overline{\text{DQS}}$) low-impedance time from CK / $\overline{\text{CK}}$	tAC,min	tAC,max	tAC,min	tAC,max	tAC,min	tAC,max	tAC,min	tAC,max	ps
tLZ(DQ)	DQ low-impedance time from CK / $\overline{\text{CK}}$	2 x tAC,min	tAC,max	2 x tAC,min	tAC,max	2 x tAC,min	tAC,max	2 x tAC,min	tAC,max	ps
tDQSQ	DQS-DQ skew (for DQS & associated DQ signals)	-	240	-	200	-	175	-	175	ps
tHP	Clock half period	Min (tCH(avg) tCL(avg))	-	Min (tCH(avg) tCL(avg))	-	Min (tCH(avg) tCL(avg))	-	Min (tCH(avg) tCL(avg))	-	ps
tQHS	Data hold skew factor	-	340	-	300	-	250	-	250	ps
tQH	Data output hold time from DQS	tHP - tQHS	-	tHP - tQHS	-	tHP - tQHS	-	tHP - tQHS	-	ps
tRPRE	Read preamble	0.9	1.1	0.9	1.1	0.9	1.1	0.9	1.1	tCK(avg)
tRPST	Read postamble	0.4	0.6	0.4	0.6	0.4	0.6	0.4	0.6	tCK(avg)
tRRD	Active bank A to Active bank B command period	X8	7.5	-	7.5	-	7.5	-	7.5	ns
		X16	10	-	10	-	10	-	10	
tFAW	Four Activate Window	X8	37.5	-	35	-	35	-	35	ns
		X16	50	-	45	-	45	-	45	
tCCD	$\overline{\text{CAS}}$ A to $\overline{\text{CAS}}$ B command period	2	-	2	-	2	-	2	-	nCK
tWR	Write recovery time	15	-	15	-	15	-	15	-	ns

512Mb DDR2 SDRAM

Symbol	Parameter	-3C/-3CI		-AC/-ACI		-BE		-BD		Units
		Min.	Max.	Min.	Max.	Min.	Max.	Min.	Max.	
tDAL	Auto-Precharge write recovery + precharge time	WR + tnRP	-	WR + tnRP	-	WR + tnRP	-	WR + tnRP	-	nCK
tWTR	Internal Write to Read command delay	7.5	-	7.5	-	7.5	-	7.5	-	ns
tRTP	Internal Read to Precharge command delay	7.5	-	7.5	-	7.5	-	7.5	-	ns
tCKE	CKE minimum high and low pulse width	3	-	3	-	3	-	3	-	nCK
tXSNR	Exit Self-Refresh to non-Read command	tRFC + 10	-	tRFC + 10	-	tRFC + 10	-	tRFC + 10	-	ns
tXSRD	Exit Self-Refresh to Read command	200	-	200	-	200	-	200	-	nCK
tXP	Exit precharge power-down to any valid command (other than NOP or Deselect)	2	-	2	-	3	-	3	-	nCK
tXARD	Exit power down to any valid command (other than NOP or Deselect)	2	-	2	-	3	-	3	-	nCK
tXARDS	Exit active power-down mode to Read command (slow exit, lower power)	7-AL	-	8-AL	-	10-AL	-	10-AL	-	nCK
tAOND	ODT turn-on delay	2	2	2	2	2	2	2	2	nCK
tAON	ODT turn-on	tAC,min	tAC,max + 0.7	tAC,min	tAC,max + 0.7	tAC,min	tAC,max + 2.575	tAC,min	tAC,max + 2.575	ns
tAONPD	ODT turn-on (Power-Down mode)	tAC,min + 2	2 x tCK(avg) + tAC,max + 1	tAC,min + 2	2 x tCK(avg) + tAC,max + 1	tAC,min + 2	3 x tCK(avg) + tAC,max + 1	tAC,min + 2	3 x tCK(avg) + tAC,max + 1	ns
tAOFD	ODT turn-off delay	2.5	2.5	2.5	2.5	2.5	2.5	2.5	2.5	nCK
tAOF	ODT turn-off	tAC,min	tAC,max + 0.6	tAC,min	tAC,max + 0.6	tAC,min	tAC,max + 0.6	tAC,min	tAC,max + 0.6	ns



512Mb DDR2 SDRAM

Symbol	Parameter	-3C/-3CI		-AC/-ACI		-BE		-BD		Units
		Min.	Max.	Min.	Max.	Min.	Max.	Min.	Max.	
tAOFPD	ODT turn-off (Power-Down mode)	tAC,min + 2	2.5 x tCK _(avg) + tAC,max + 1	tAC,min + 2	2.5 x tCK _(avg) + tAC,max + 1	tAC,min + 2	2.5 x tCK _(avg) + tAC,max + 1	tAC,min + 2	2.5 x tCK _(avg) + tAC,max + 1	ns
tANPD	ODT to power down entry latency	3	-	3	-	4	-	4	-	nCK
tAXPD	ODT power down exit latency	8	-	8	-	11	-	11	-	nCK
tMRD	Mode register set command cycle time	2	-	2	-	2	-	2	-	nCK
tMOD	MRS command to ODT update delay	0	12	0	12	0	12	0	12	ns
tOIT	OCD drive mode output delay	0	12	0	12	0	12	0	12	ns
tDELAY	Minimum time clocks remain ON after CKE asynchronously drops LOW	tIS + tCK _(avg) + tIH	-	tIS + tCK _(avg) + tIH	-	tIS + tCK _(avg) + tIH	-	tIS + tCK _(avg) + tIH	-	ns

512Mb DDR2 SDRAM

General Note 1 DDR2 SDRAM AC timing reference load

The figure represents the timing reference load used in defining the relevant timing parameters of the device. It is not intended to either a precise representation of the typical system environment or a depiction of the actual load presented by a production tester. System designers should use IBIS or other simulation tools to correlate the timing reference load to a system environment. Manufacturers correlate to their production test conditions, generally a coaxial transmission line terminated at the tester electronics. This reference load is also used for output slew rate characterization.

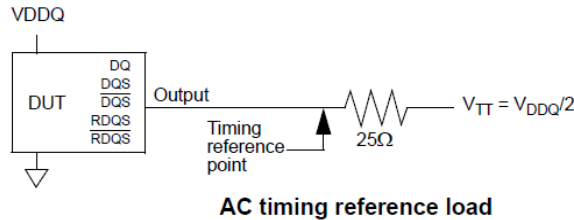

The output timing reference voltage level for single ended signals is the cross point with V_{TT} .
 The output timing reference voltage level for differential signals is the cross point of the true (e.g. DQS) and the complement (e.g. \overline{DQS}) signal.

General Note 2 Slew Rate Measurement Levels

- a) Output slew rate for falling and rising edges is measured between $V_{TT} - 250\text{ mV}$ and $V_{TT} + 250\text{ mV}$ for single ended signals. For differential signals (e.g. DQS - \overline{DQS}) output slew rate is measured between $DQS - \overline{DQS} = -500\text{ mV}$ and $DQS - \overline{DQS} = +500\text{ mV}$. Output slew rate is guaranteed by design, but is not necessarily tested on each device.
- b) Input slew rate for single ended signals is measured from $V_{ref}(dc)$ to $V_{IH}(ac),min$ for rising edges and from $V_{ref}(dc)$ to $V_{IL}(ac),max$ for falling edges.
 For differential signals (e.g. CK - \overline{CK}) slew rate for rising edges is measured from $CK - \overline{CK} = -250\text{ mV}$ to $CK - \overline{CK} = +500\text{ mV}$ (+ 250 mV to - 500 mV for falling edges).
- c) VID is the magnitude of the difference between the input voltage on CK and the input voltage on \overline{CK} , or between DQS and \overline{DQS} for differential strobe.

General Note 3 DDR2 SDRAM output slew rate test load

Output slew rate is characterized under the test conditions as following

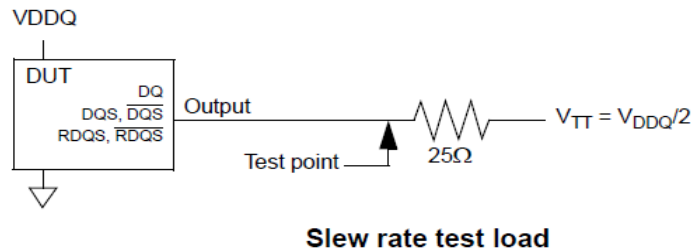

512Mb DDR2 SDRAM

General Note 4 Differential data strobe

DDR2 SDRAM pin timings are specified for either single ended mode or differential mode depending on the setting of the EMRS “Enable DQS” mode bit; timing advantages of differential mode are realized in system design. The method by which the DDR2 SDRAM pin timings are measured is mode dependent. In single ended mode, timing relationships are measured relative to the rising or falling edges of DQS crossing at VREF. In differential mode, these timing relationships are measured relative to the crosspoint of DQS and its complement, \overline{DQS} . This distinction in timing methods is guaranteed by design and characterization. Note that when differential data strobe mode is disabled via the EMRS, the complementary pin, \overline{DQS} , must be tied externally to VSS through a 20 Ω to 10 k Ω resistor to insure proper operation.

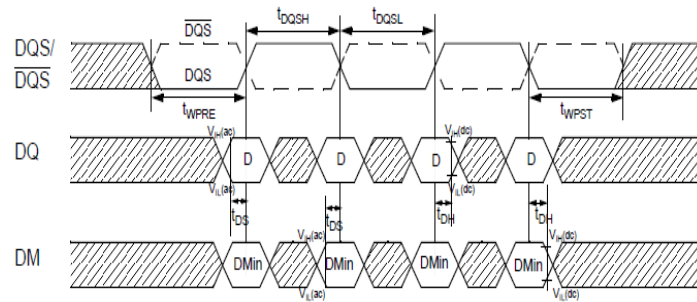

Data Input (Write) Timing

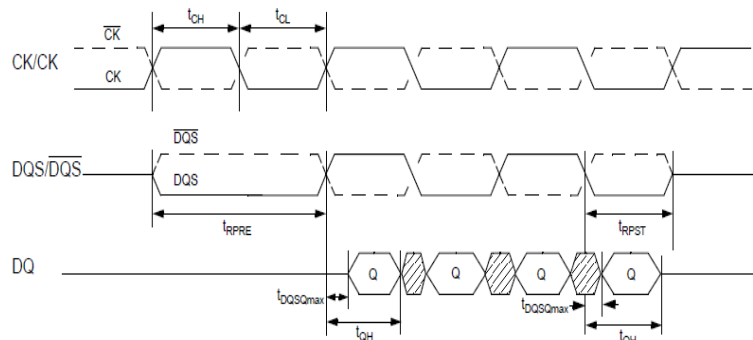

Data output (read) timing

General Note 5 AC timings are for linear signal transitions. See Specific Notes on derating for other signal transitions.

General Note 6 All voltages are referenced to VSS.

General Note 7 These parameters guarantee device behavior, but they are not necessarily tested on each device..

General Note 8 Tests for AC timing, IDD, and electrical (AC and DC) characteristics, may be conducted at nominal reference/supply voltage levels, but the related specifications and device operation are guaranteed for the full voltage range specified.



512Mb DDR2 SDRAM

Specific notes for dedicated AC parameters

Specific Note 1 User can choose which active power down exit timing to use via MRS (bit 12). tXARD is expected to be used for fast active power down exit timing. tXARDS is expected to be used for slow active power down exit timing where a lower power value is defined by each vendor data sheet.

Specific Note 2 AL = Additive Latency.

Specific Note 3 This is a minimum requirement. Minimum read to precharge timing is AL + BL / 2 provided that the tRTP and tRAS(min) have been satisfied.

Specific Note 4 A minimum of two clocks (2 x tCK or 2 x nCK) is required irrespective of operating frequency.

Specific Note 5 Timings are specified with command/address input slew rate of 1.0 V/ns. See Specific Notes on derating for other slew rate values.

Specific Note 6 Timings are specified with DQs, DM, and DQS's (DQS/RDQS in single ended mode) input slew rate of 1.0V/ns. See Specific Notes on derating for other slew rate values.

Specific Note 7 Timings are specified with CK/ \overline{CK} differential slew rate of 2.0 V/ns. Timings are guaranteed for DQS signals with a differential slew rate of 2.0 V/ns in differential strobe mode and a slew rate of 1 V/ns in single ended mode. See Specific Notes on derating for other slew rate values.

Specific Note 8 Data setup and hold time derating.

Data Setup (tDS) and Hold Time (tDH) Derating Table with differential data strobe

		DQS, \overline{DQS} Differential Slew Rate (-3C/-3CI/-AC/-ACI/-ACL/-BE/-BD)																	
		4.0 V/ns		3.0 V/ns		2.0 V/ns		1.8 V/ns		1.6 V/ns		1.4 V/ns		1.2 V/ns		1.0 V/ns		0.8 V/ns	
		D tDS	D tDH	D tDS	D tDH	D tDS	D tDH	D tDS	D tDH	D tDS	D tDH	D tDS	D tDH	D tDS	D tDH	D tDS	D tDH	D tDS	D tDH
DQ Slewrate (V/ns)	2.0	100	45	100	45	100	45	-	-	-	-	-	-	-	-	-	-	-	-
	1.5	67	21	67	21	67	21	79	33	-	-	-	-	-	-	-	-	-	-
	1.0	0	0	0	0	0	0	12	12	24	24	-	-	-	-	-	-	-	-
	0.9	-	-	-5	-14	-5	-14	7	-2	19	10	31	22	-	-	-	-	-	-
	0.8	-	-	-	-	-13	-31	-1	-19	11	-7	23	5	35	17	-	-	-	-
	0.7	-	-	-	-	-	-	-10	-42	2	-30	14	-18	26	-6	38	6	-	-
	0.6	-	-	-	-	-	-	-	-	-10	-59	2	-47	14	-35	26	-23	38	-11
	0.5	-	-	-	-	-	-	-	-	-	-	-24	-89	-12	-77	0	-65	12	-53
	0.4	-	-	-	-	-	-	-	-	-	-	-	-	-52	-140	-40	-128	-28	-116

1. All units in ps.

2. For all input signals the total Tds (setup time) and Tdh (hold time) required is calculated by adding the individual datasheet value to the derating value listed in the previous table

512Mb DDR2 SDRAM

Specific Note 9 tIS and tIH (input setup and hold) derating

Input Setup (t_{IS}) and Hold (t_{IH}) Time Derating Table

		CK, \overline{CK} Differential Slew Rate						Units
		(-3C/-3CI/-AC/-ACI/-ACL/-BE/-BD)						
		2.0 V/ns		1.5 V/ns		1.0 V/ns		
		D tIS	D tIH	D tIS	D tIH	D tIS	D tIH	
Command/Address Slew rate (V/ns)	4.00	150	94	180	124	210	154	ps
	3.50	143	89	173	119	203	149	ps
	3.00	133	83	163	113	193	143	ps
	2.50	120	75	150	105	180	135	ps
	2.00	100	45	130	75	160	105	ps
	1.50	67	21	97	51	127	81	ps
	1.00	0	0	30	30	60	60	ps
	0.90	-5	-14	25	16	55	46	ps
	0.80	-13	-31	17	-1	47	29	ps
	0.70	-22	-54	8	-24	38	6	ps
	0.60	-34	-83	-4	-53	26	-23	ps
	0.50	-60	-125	-30	-95	0	-65	ps
	0.40	-100	-188	-70	-158	-40	-128	ps
	0.30	-168	-292	-138	-262	-108	-232	ps
	0.25	-200	-375	-170	-345	-140	-315	ps
	0.20	-325	-500	-295	-470	-265	-440	ps
0.15	-517	-708	-487	-678	-457	-648	ps	
0.10	-1000	-1125	-970	-1095	-940	-1065	ps	

Setup (tIS & tDS) nominal slew rate for a rising signal is defined as the slew rate between the last crossing of VIH(dc)min and the first crossing of VIH(ac)min. Setup (tIS & tDS) nominal slew rate for a falling signal is defined as the slew rate between the last crossing of VIL(dc)max and the first crossing of VIL(ac)max, If the actual signal is always earlier than the nominal slew rate line between shaded 'dc to ac region', use nominal slew rate for derating value. If the actual signal is later than the nominal slew rate line anywhere between shaded 'dc to ac region', the slew rate of a tangent line to the actual signal from the ac level to dc level is used for derating value.

Hold (tIH & tDH) nominal slew rate for a rising signal is defined as the slew rate between the last crossing of VIL (dc) max and the first crossing of Vref. Hold (tIH & tDH) nominal slew rate for a falling signal is defined as the slew rate between the last crossing of VIH(dc)min and the first crossing of Vref. If the actual signal is always later than the nominal slew rate line between shaded 'dc to Vref region', use nominal slew rate for derating value. If the actual signal is earlier than the nominal slew rate line anywhere between shaded 'dc to Vref region', the slew rate of a tangent line to the actual signal from the dc level to Vref level is used for derating value.

512Mb DDR2 SDRAM

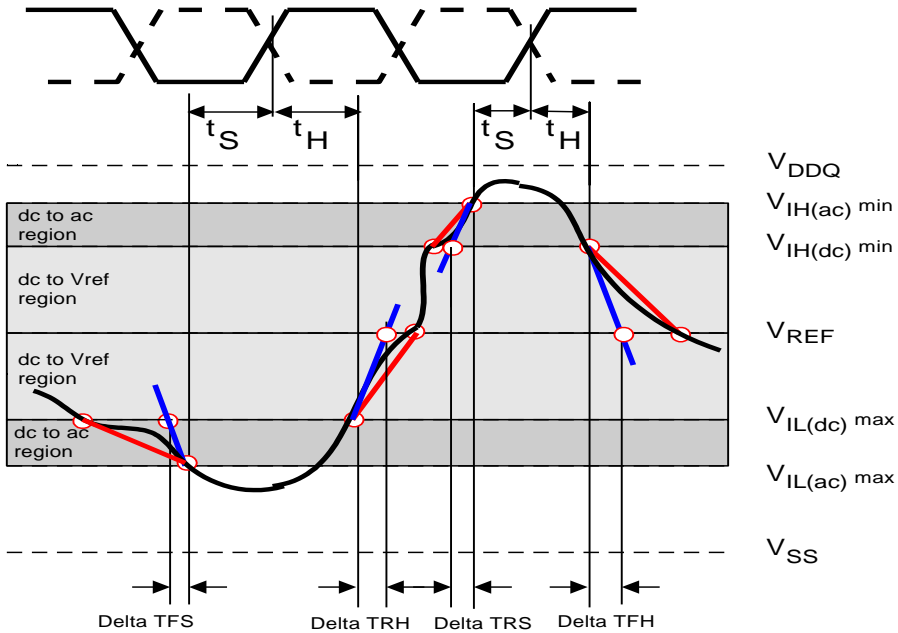
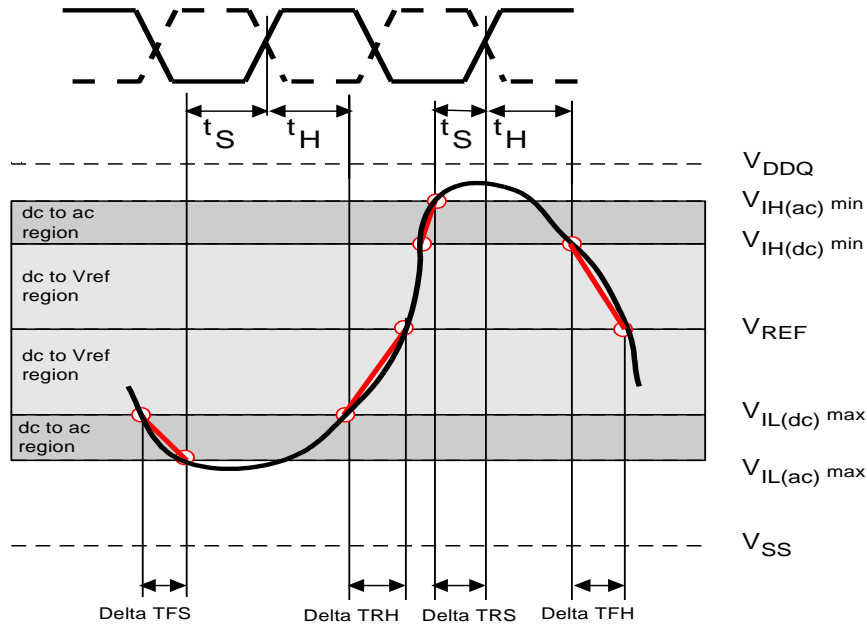

$$\text{Setup Slew Rate} = \frac{V_{IL(dc)max} - V_{IL(ac)max}}{\Delta t_{TFS}} \quad \text{falling signal}$$

$$\text{Setup Slew Rate} = \frac{V_{IH(dc)min} - V_{IL(ac)min}}{\Delta t_{TRS}} \quad \text{rising signal}$$

$$\text{Hold Slew Rate} = \frac{V_{REF} - V_{IL(dc)max}}{\Delta t_{TRH}} \quad \text{rising signal}$$

$$\text{Hold Slew Rate} = \frac{V_{IH(dc)min} - V_{REF}}{\Delta t_{TFH}} \quad \text{falling signal}$$

$$\text{Setup Slew Rate} = \frac{\text{tangent line } [V_{IL(dc)max} - V_{IL(ac)max}]}{\Delta t_{TFS}} \quad \text{falling signal}$$

$$\text{Setup Slew Rate} = \frac{\text{tangent line } [V_{IH(dc)min} - V_{IL(ac)min}]}{\Delta t_{TRS}} \quad \text{rising signal}$$

$$\text{Hold Slew Rate} = \frac{\text{tangent line } [V_{REF} - V_{IL(dc)max}]}{\Delta t_{TRH}} \quad \text{rising signal}$$

$$\text{Hold Slew Rate} = \frac{\text{tangent line } [V_{IH(dc)min} - V_{REF}]}{\Delta t_{TFH}} \quad \text{falling signal}$$

Specific Note 10 The maximum limit for this parameter is not a device limit. The device will operate with a greater value for this parameter, but system performance (bus turnaround) will degrade accordingly.

Specific Note 11 MIN (tCL, tCH) refers to the smaller of the actual clock LOW time and the actual clock HIGH

512Mb DDR2 SDRAM

time as provided to the device (i.e. this value can be greater than the minimum specification limits for tCL and tCH). For example, tCL and tCH are = 50% of the period, less the half period jitter (tJIT(HP)) of the clock source, and less the half period jitter due to crosstalk (tJIT(crosstalk)) into the clock traces.

Specific Note 12 tQH = tHP – tQHS, where:

tHP = minimum half clock period for any given cycle and is defined by clock HIGH or clock LOW (tCH, tCL).

tQHS accounts for:

- 1) The pulse duration distortion of on-chip clock circuits; and
- 2) The worst case push-out of DQS on one transition followed by the worst case pull-in of DQ on the next transition, both of which are, separately, due to data pin skew and output pattern effects, and p-channel to n-channel variation of the output drivers.

Specific Note 13 tDQSQ: Consists of data pin skew and output pattern effects, and p-channel to n-channel variation of the output drivers as well as output slew rate mismatch between DQS / DQS and associated DQ in any given cycle.

Specific Note 14 tDAL = WR + RU{ tRP[ns] / tCK[ns] }, where RU stands for round up.

WR refers to the tWR parameter stored in the MRS. For tRP, if the result of the division is not already an integer, round up to the next highest integer. tCK refers to the application clock period.

Example: For DDR533 at tCK = 3.75ns with WR programmed to 4 clocks.

tDAL = 4 + (15 ns / 3.75 ns) clocks = 4 + (4) clocks = 8 clocks.

Specific Note 15 The clock frequency is allowed to change during self-refresh mode or precharge power-down mode. In case of clock frequency change during precharge power-down, a specific procedure is required.

Specific Note 16 ODT turn on time min is when the device leaves high impedance and ODT resistance begins to turn on. ODT turn on time max is when the ODT resistance is fully on. Both are measured from tAOND, which is interpreted differently per speed bin. For DDR2-667/800, tAOND is 2 clock cycles after the clock edge that registered a first ODT HIGH counting the actual input clock edges.

Specific Note 17 ODT turn off time min is when the device starts to turn off ODT resistance. ODT turn off time max is when the bus is in high impedance. Both are measured from tAOFD, which is interpreted differently per speed bin. For DDR2-667/800, if tCK(avg) = 3 ns is assumed, tAOFD is 1.5 ns (= 0.5 x 3 ns) after the second trailing clock edge counting from the clock edge that registered a first ODT LOW and by counting the actual input clock edges.

Specific Note 18 tHZ and tLZ transitions occur in the same access time as valid data transitions. These parameters are referenced to a specific voltage level which specifies when the device output is no longer driving (tHZ), or begins driving (tLZ) .The following figure shows a method to calculate the point when device is no longer driving (tHZ), or begins driving (tLZ) by measuring the signal at two different voltages. The actual voltage measurement points are not critical as long as the calculation is consistent. tLZ(DQ) refers to tLZ of the DQ's and tLZ(DQS) refers to tLZ of the (U/L/R)DQS and $\overline{(U/L/R)DQS}$ each treated as single-ended signal.

Specific Note 19 tRPST end point and tRPRE begin point are not referenced to a specific voltage level but specify when the device output is no longer driving (tRPST), or begins driving (tRPRE). The following figure

512Mb DDR2 SDRAM

shows a method to calculate these points when the device is no longer driving (tRPST), or begins driving (tRPRE) by measuring the signal at two different voltages. The actual voltage measurement points are not critical as long as the calculation is consistent.

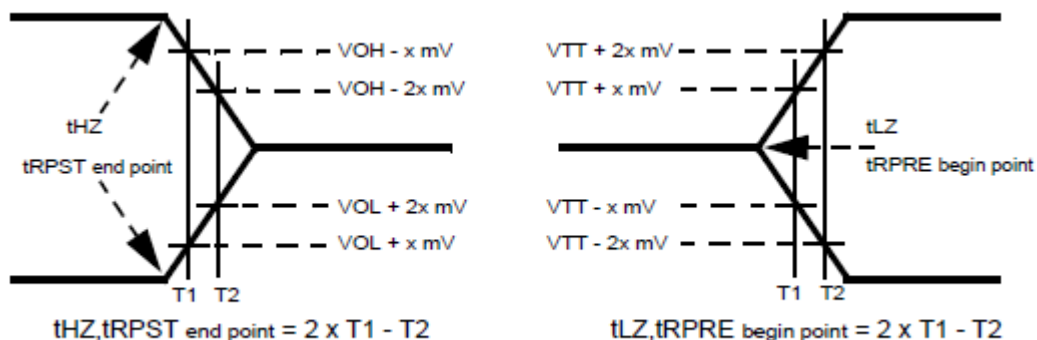

Method for calculating transitions and endpoints

Specific Note 20 Input waveform timing tDS with differential data strobe enabled MR[bit10]=0, is referenced from the input signal crossing at the VIH(ac) level to the differential data strobe crosspoint for a rising signal, and from the input signal crossing at the VIL(ac) level to the differential data strobe crosspoint for a falling signal applied to the device under test. DQS, \overline{DQS} signals must be monotonic between Vil(dc)max and Vih(dc)min.

Specific Note 21 Input waveform timing tDH with differential data strobe enabled MR[bit10]=0, is referenced from the differential data strobe crosspoint to the input signal crossing at the VIH(dc) level for a falling signal and from the differential data strobe crosspoint to the input signal crossing at the VIL(dc) level for a rising signal applied to the device under test. DQS, \overline{DQS} signals must be monotonic between Vil(dc)max and Vih(dc)min.

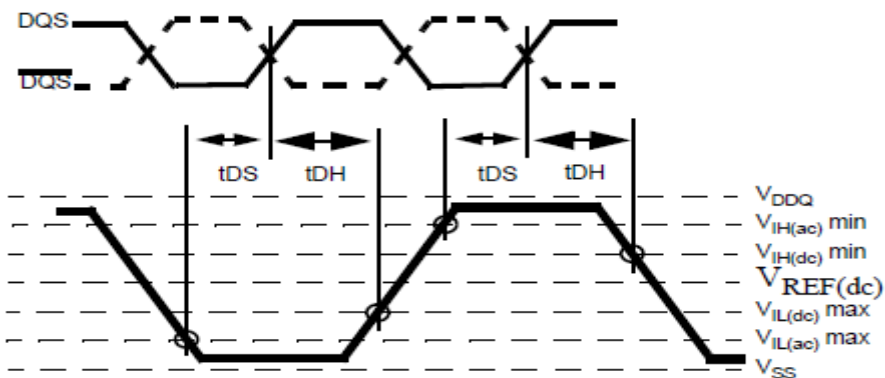

Differential input waveform timing – tDS and tDH

Specific Note 22 Input waveform timing is referenced from the input signal crossing at the VIH(ac) level for a rising signal and VIL(ac) for a falling signal applied to the device under test.

Specific Note 23 Input waveform timing is referenced from the input signal crossing at the VIL(dc) level for a rising signal and VIH(dc) for a falling signal applied to the device under test.

512Mb DDR2 SDRAM

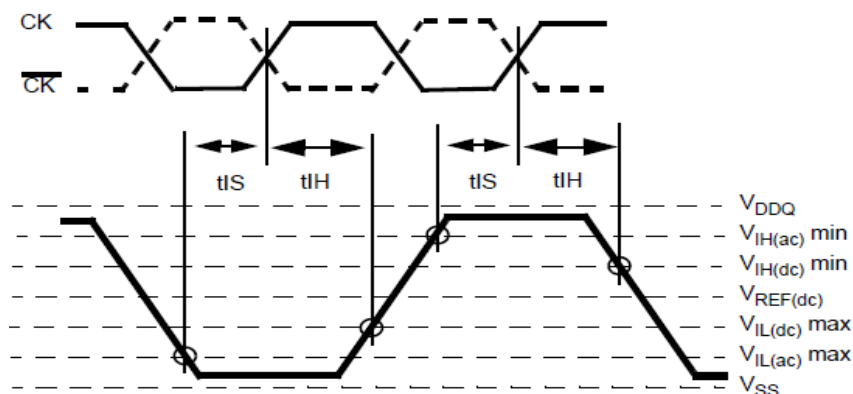
Differential input waveform timing – t_{IS} and t_{IH}

Specific Note 24 t_{WTR} is at least two clocks ($2 \times t_{CK}$ or $2 \times n_{CK}$) independent of operation frequency.

Specific Note 25 Input waveform timing with single-ended data strobe enabled $MR[\text{bit}10] = 1$, is referenced from the input signal crossing at the $V_{IH(ac)}$ level to the single-ended data strobe crossing $V_{IH/L(dc)}$ at the start of its transition for a rising signal, and from the input signal crossing at the $V_{IL(ac)}$ level to the single-ended data strobe crossing $V_{IH/L(dc)}$ at the start of its transition for a falling signal applied to the device under test. The DQS signal must be monotonic between $V_{il(dc)\max}$ and $V_{ih(dc)\min}$.

Specific Note 26 Input waveform timing with single-ended data strobe enabled $MR[\text{bit}10] = 1$, is referenced from the input signal crossing at the $V_{IH(dc)}$ level to the single-ended data strobe crossing $V_{IH/L(ac)}$ at the end of its transition for a rising signal, and from the input signal crossing at the $V_{IL(dc)}$ level to the single-ended data strobe crossing $V_{IH/L(ac)}$ at the end of its transition for a falling signal applied to the device under test. The DQS signal must be monotonic between $V_{il(dc)\max}$ and $V_{ih(dc)\min}$.

Specific Note 27 $t_{CKE\min}$ of 3 clocks means CKE must be registered on three consecutive positive clock edges. CKE must remain at the valid input level the entire time it takes to achieve the 3 clocks of registration. Thus, after any CKE transition, CKE may not transition from its valid level during the time period of $t_{IS} + 2 \times t_{CK} + t_{IH}$.

Specific Note 28 If t_{DS} or t_{DH} is violated, data corruption may occur and the data must be re-written with valid data before a valid READ can be executed.

Specific Note 29 These parameters are measured from a command/address signal (\overline{CKE} , \overline{CS} , \overline{RAS} , \overline{CAS} , \overline{WE} , ODT, BA0, A0, A1, etc.) transition edge to its respective clock signal (CK/\overline{CK}) crossing. The spec values are not affected by the amount of clock jitter applied (i.e. $t_{JIT(per)}$, $t_{JIT(cc)}$, etc.), as the setup and hold are relative to the clock signal crossing that latches the command/address. That is, these parameters should be met whether clock jitter is present or not.

Specific Note 30 These parameters are measured from a data strobe signal ($(L/U/R)DQS/\overline{DQS}$) crossing to its respective clock signal (CK/\overline{CK}) crossing. The spec values are not affected by the amount of clock jitter applied (i.e. $t_{JIT(per)}$, $t_{JIT(cc)}$, etc.), as these are relative to the clock signal crossing. That is, these parameters should be met whether clock jitter is present or not.

Specific Note 31 These parameters are measured from a data signal ($(L/U)DM$, $(L/U)DQ0$, $(L/U)DQ1$, etc.) transition edge to its respective data strobe signal ($(L/U/R)DQS/\overline{DQS}$) crossing.

512Mb DDR2 SDRAM

Specific Note 32 For these parameters, the DDR2 SDRAM device is characterized and verified to support $tnPARAM = RU\{tPARAM / tCK(avg)\}$, which is in clock cycles, assuming all input clock jitter specifications are satisfied.

For example, the device will support $tnRP = RU\{tRP / tCK(avg)\}$, which is in clock cycles, if all input clock jitter specifications are met. This means: For DDR2-667 5-5-5, of which $tRP = 15ns$, the device will support $tnRP = RU\{tRP / tCK(avg)\} = 5$, i.e. as long as the input clock jitter specifications are met, Precharge command at Tm and active command at $Tm+5$ is valid even if $(Tm+5 - Tm)$ is less than 15ns due to input clock jitter.

Specific Note 33 $tDAL [nCK] = WR [nCK] + tnRP [nCK] = WR + RU \{tRP [ps] / tCK(avg) [ps]\}$, where WR is the value programmed in the mode register set.

Specific Note 34 New units, 'tCK(avg)' and 'nCK', are introduced in DDR2-667 and DDR2-800.

Unit 'tCK(avg)' represents the actual tCK(avg) of the input clock under operation.

Unit 'nCK' represents one clock cycle of the input clock, counting the actual clock edges.

ex) $tXP = 2 [nCK]$ means; if Power Down exit is registered at Tm , an Active command may be registered at $Tm+2$, even if $(Tm+2 - Tm)$ is $2 \times tCK(avg) + tERR(2per)$, min.

Specific Note 35 Input clock jitter spec parameter. These parameters and the ones in the table below are referred to as 'input clock jitter spec parameters' and these parameters apply. The jitter specified is a random jitter meeting a Gaussian distribution.

Input clock jitter spec parameter apply to DDR2-667, DDR2-800 and DDR2-1066

Parameter	Symbol	DDR2-667		DDR2-800		DDR2-1066		Units
		min	max	min	max	min	max	
Clock period jitter	tJIT(per)	-125	125	-100	100	-90	90	ps
Clock period jitter during DLL locking period	tJIT(per,lck)	-100	100	-80	80	-80	80	ps
Cycle to cycle clock period jitter	tJIT(cc)	-250	250	-200	200	-180	180	ps
Cycle to cycle clock period jitter during DLL locking period	tJIT(cc,lck)	-200	200	-160	160	-160	160	ps
Cumulative error across 2 cycles	tERR(2per)	-175	175	-150	150	-132	132	ps
Cumulative error across 3 cycles	tERR(3per)	-225	225	-175	175	-157	157	ps
Cumulative error across 4 cycles	tERR(4per)	-250	250	-200	200	-175	175	ps
Cumulative error across 5 cycles	tERR(5per)	-250	250	-200	200	-188	188	ps
Cumulative error across n cycles, n = 6 ... 10, inclusive	tERR(6-10per)	-350	350	-300	300	-250	250	ps
Cumulative error across n cycles, n = 11 ... 50, inclusive	tERR(11-50per)	-450	450	-450	450	-425	425	ps
Duty cycle jitter	tJIT(duty)	-125	125	-100	100	-75	75	ps

512Mb DDR2 SDRAM

Definitions:

- tCK(avg)

tCK(avg) is calculated as the average clock period across any consecutive 200 cycle window.

$$tCK(avg) = \left(\sum_{j=1}^N tCK_j \right) / N$$

where $N = 200$

- tCH(avg) and tCL(avg)

tCH(avg) is defined as the average HIGH pulse width, as calculated across any consecutive 200 HIGH pulses.

$$tCH(avg) = \left(\sum_{j=1}^N tCH_j \right) / (N \times tCK(avg))$$

where $N = 200$

tCL(avg) is defined as the average LOW pulse width, as calculated across any consecutive 200 LOW pulses.

$$tCL(avg) = \left(\sum_{j=1}^N tCL_j \right) / (N \times tCK(avg))$$

where $N = 200$

- tJIT(duty)

tJIT(duty) is defined as the cumulative set of tCH jitter and tCL jitter. tCH jitter is the largest deviation of any single tCH from tCH(avg). tCL jitter is the largest deviation of any single tCL from tCL(avg).

$$tJIT(duty) = \text{Min/max of } \{tJIT(CH), tJIT(CL)\}$$

where,

$$tJIT(CH) = \{tCH_i - tCH(avg) \text{ where } i=1 \text{ to } 200\}$$

$$tJIT(CL) = \{tCL_i - tCL(avg) \text{ where } i=1 \text{ to } 200\}$$

- tJIT(per), tJIT(per,lck)

tJIT(per) is defined as the largest deviation of any single tCK from tCK(avg).

$$tJIT(per) = \text{Min/max of } \{tCK_i - tCK(avg) \text{ where } i=1 \text{ to } 200\}$$

tJIT(per) defines the single period jitter when the DLL is already locked.

tJIT(per,lck) uses the same definition for single period jitter, during the DLL locking period only.

tJIT(per) and tJIT(per,lck) are not guaranteed through final production testing.

- tJIT(cc), tJIT(cc,lck)

tJIT(cc) is defined as the difference in clock period between two consecutive clock cycles:

$$tJIT(cc) = \text{Max of } |tCK_{i+1} - tCK_i|$$

tJIT(cc) defines the cycle to cycle jitter when the DLL is already locked.

tJIT(cc,lck) uses the same definition for cycle to cycle jitter, during the DLL locking period only.

512Mb DDR2 SDRAM

tJIT(cc) and tJIT(cc,lck) are not guaranteed through final production testing.

- tERR(2per), tERR(3per), tERR(4per), tERR(5per), tERR(6-10per) and tERR(11-50per)

tERR is defined as the cumulative error across multiple consecutive cycles from tCK(avg).

$$tERR(nper) = \left(\sum_{j=1}^{i+n-1} tCK_j \right) - n \times tCK(avg)$$

$$\text{where } \begin{cases} n = 2 & \text{for } tERR(2per) \\ n = 3 & \text{for } tERR(3per) \\ n = 4 & \text{for } tERR(4per) \\ n = 5 & \text{for } tERR(5per) \\ 6 \leq n \leq 10 & \text{for } tERR(6-10per) \\ 11 \leq n \leq 50 & \text{for } tERR(11-50per) \end{cases}$$

Specific Note 36 These parameters are specified per their average values, however it is understood that the following relationship between the average timing and the absolute instantaneous timing holds at all times.

(min and max of SPEC values are to be used for calculations in the table below.)

Parameter	Symbol	min	max	Units
Absolute clock period	tCK(abs)	tCK(avg),min + tJIT(per),min	tCK(avg),max + tJIT(per),max	ps
Absolute clock HIGH pulse width	tCH(abs)	tCH(avg),min x tCK(avg),min + tJIT(duty),min	tCH(avg),max x tCK(avg),max + tJIT(duty),max	ps
Absolute clock LOW pulse width	tCL(abs)	tCL(avg),min x tCK(avg),min + tJIT(duty),min	tCL(avg),max x tCK(avg),max + tJIT(duty),max	ps

Example: For DDR2-667, tCH(abs),min = (0.48 x 3000 ps) - 125 ps = 1315 ps

Specific Note 37 tHP is the minimum of the absolute half period of the actual input clock. tHP is an input parameter but not an input specification parameter. It is used in conjunction with tQHS to derive the DRAM output timing tQH. The value to be used for tQH calculation is determined by the following equation;

$$tHP = \text{Min} (tCH(abs), tCL(abs)),$$

where,

tCH(abs) is the minimum of the actual instantaneous clock HIGH time;

tCL(abs) is the minimum of the actual instantaneous clock LOW time;

Specific Note 38 tQHS accounts for:

- 1) The pulse duration distortion of on-chip clock circuits, which represents how well the actual tHP at the input is transferred to the output; and
- 2) The worst case push-out of DQS on one transition followed by the worst case pull-in of DQ on the next transition, both of which are independent of each other, due to data pin skew, output pattern effects, and pchannel to n-channel variation of the output drivers

Specific Note 39 tQH = tHP – tQHS, where:

tHP is the minimum of the absolute half period of the actual input clock; and tQHS is the specification value under the max column.

{The less half-pulse width distortion present, the larger the tQH value is; and the larger the valid data eye

512Mb DDR2 SDRAM

will be.}

Examples:

- 1) If the system provides tHP of 1315 ps into a DDR2-667 SDRAM, the DRAM provides tQH of 975 ps minimum.
- 2) If the system provides tHP of 1420 ps into a DDR2-667 SDRAM, the DRAM provides tQH of 1080 ps minimum.

Specific Note 40 When the device is operated with input clock jitter, this parameter needs to be derated by the actual tERR(6-10per) of the input clock. (output deratings are relative to the SDRAM input clock.)

For example, if the measured jitter into a DDR2-667 SDRAM has tERR(6-10per),min = - 272 ps and tERR(6-10per),max = + 293 ps, then tDQSCK,min(derated) = tDQSCK,min - tERR(6-10per),max = - 400 ps - 293 ps = - 693 ps and tDQSCK,max(derated) = tDQSCK,max - tERR(6-10per),min = 400 ps + 272 ps = + 672 ps. Similarly, tLZ(DQ) for DDR2-667 derates to tLZ(DQ),min(derated) = - 900 ps - 293 ps = - 1193 ps and tLZ(DQ),max(derated) = 450 ps + 272 ps = + 722 ps. (Caution on the min/max usage!)

Specific Note 41 When the device is operated with input clock jitter, this parameter needs to be derated by the actual tJIT(per) of the input clock. (output deratings are relative to the SDRAM input clock.)

For example, if the measured jitter into a DDR2-667 SDRAM has tJIT(per),min = - 72 ps and tJIT(per),max = + 93 ps, then tRPRE,min(derated) = tRPRE,min + tJIT(per),min = 0.9 x tCK(avg) - 72 ps = + 2178 ps and tRPRE,max(derated) = tRPRE,max + tJIT(per),max = 1.1 x tCK(avg) + 93 ps = + 2843 ps. (Caution on the min/max usage!)

Specific Note 42 When the device is operated with input clock jitter, this parameter needs to be derated by the actual tJIT(duty) of the input clock. (output deratings are relative to the SDRAM input clock.)

For example, if the measured jitter into a DDR2-667 SDRAM has tJIT(duty),min = - 72 ps and tJIT(duty),max = + 93ps, then tRPST,min(derated) = tRPST,min + tJIT(duty),min = 0.4 x tCK(avg) - 72 ps = + 928 ps and tRPST,max(derated) = tRPST,max + tJIT(duty),max = 0.6 x tCK(avg) + 93 ps = + 1592 ps. (Caution on the min/max usage!)

Specific Note 43 When the device is operated with input clock jitter, this parameter needs to be derated by { - tJIT(duty),max - tERR(6-10per),max } and { - tJIT(duty),min - tERR(6-10per),min } of the actual input clock. (output deratings are relative to the SDRAM input clock.)

For example, if the measured jitter into a DDR2-667 SDRAM has tERR(6-10per),min = - 272 ps, tERR(6-10per),max = + 293 ps, tJIT(duty),min = - 106 ps and tJIT(duty),max = + 94 ps, then tAOF,min(derated) = tAOF,min + { - tJIT(duty),max - tERR(6-10per),max } = - 450 ps + { - 94 ps - 293 ps } = - 837 ps and tAOF,max(derated) = tAOF,max + { - tJIT(duty),min - tERR(6-10per),min } = 1050 ps + { 106 ps + 272 ps } = + 1428 ps. (Caution on the min/max usage!)

Specific Note 44 For tAOFD of DDR2-667/800, the 1/2 clock of nCK in the 2.5 x nCK assumes a tCH(avg), average input clock HIGH pulse width of 0.5 relative to tCK(avg). tAOF,min and tAOF,max should each be derated

by the same amount as the actual amount of tCH(avg) offset present at the DRAM input with respect to 0.5. For example, if an input clock has a worst case tCH(avg) of 0.48, the tAOF,min should be derated by subtracting

512Mb DDR2 SDRAM

$0.02 \times tCK(\text{avg})$ from it, whereas if an input clock has a worst case $tCH(\text{avg})$ of 0.52, the $tAOF, \text{max}$ should be derated by adding $0.02 \times tCK(\text{avg})$ to it. Therefore, we have;

$$tAOF, \text{min}(\text{derated}) = tAC, \text{min} - [0.5 - \text{Min}(0.5, tCH(\text{avg}), \text{min})] \times tCK(\text{avg})$$

$$tAOF, \text{max}(\text{derated}) = tAC, \text{max} + 0.6 + [\text{Max}(0.5, tCH(\text{avg}), \text{max}) - 0.5] \times tCK(\text{avg})$$

or

$$tAOF, \text{min}(\text{derated}) = \text{Min}(tAC, \text{min}, tAC, \text{min} - [0.5 - tCH(\text{avg}), \text{min}] \times tCK(\text{avg}))$$

$$tAOF, \text{max}(\text{derated}) = 0.6 + \text{Max}(tAC, \text{max}, tAC, \text{max} + [tCH(\text{avg}), \text{max} - 0.5] \times tCK(\text{avg}))$$

where $tCH(\text{avg}), \text{min}$ and $tCH(\text{avg}), \text{max}$ are the minimum and maximum of $tCH(\text{avg})$ actually measured at the DRAM input balls.

Note that these deratings are in addition to the $tAOF$ derating per input clock jitter, i.e. $tJIT(\text{duty})$ and $tERR(6-10\text{per})$.

However tAC values used in the equations shown above are from the timing parameter table and are not derated.

Thus the final derated values for $tAOF$ are;

$$tAOF, \text{min}(\text{derated_final}) = tAOF, \text{min}(\text{derated}) + \{ - tJIT(\text{duty}), \text{max} - tERR(6-10\text{per}), \text{max} \}$$

$$tAOF, \text{max}(\text{derated_final}) = tAOF, \text{max}(\text{derated}) + \{ - tJIT(\text{duty}), \text{min} - tERR(6-10\text{per}), \text{min} \}$$

512Mb DDR2 SDRAM

Overshoot and Undershoot Specification

AC Overshoot / Undershoot Specification for Address and Control Pins

Parameter	-3C/-3CI	-AC/-ACI	-BE	-BD	Units
Maximum peak amplitude allowed for overshoot area	0.5	0.5	0.5	0.5	V
Maximum peak amplitude allowed for undershoot area	0.5	0.5	0.5	0.5	V
Maximum overshoot area above VDD	0.8	0.66	0.66	0.66	V-ns
Maximum undershoot area below VSS	0.8	0.66	0.66	0.66	V-ns

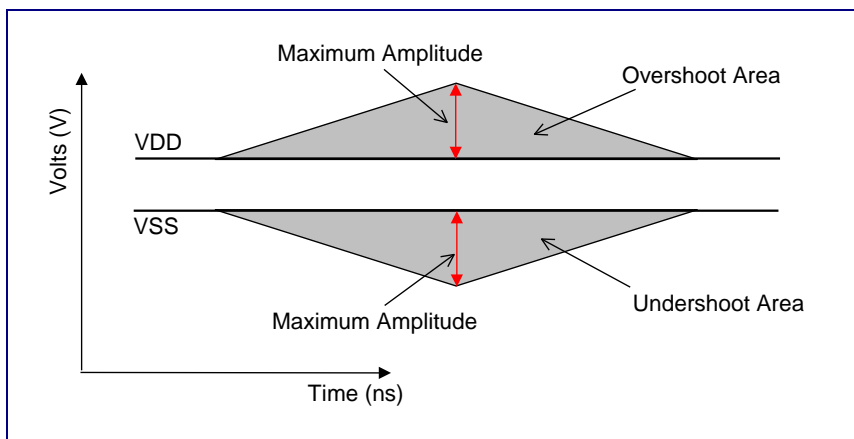

AC Overshoot / Undershoot Specification for Clock, Data, Strobe and Mask Pins

Parameter	-3C/-3CI	-AC/-ACI	-BE	-BD	Units
Maximum peak amplitude allowed for overshoot area	0.5	0.5	0.5	0.5	V
Maximum peak amplitude allowed for undershoot area	0.5	0.5	0.5	0.5	V
Maximum overshoot area above VDDQ	0.23	0.23	0.23	0.23	V.ns
Maximum undershoot area below VSSQ	0.23	0.23	0.23	0.23	V.ns

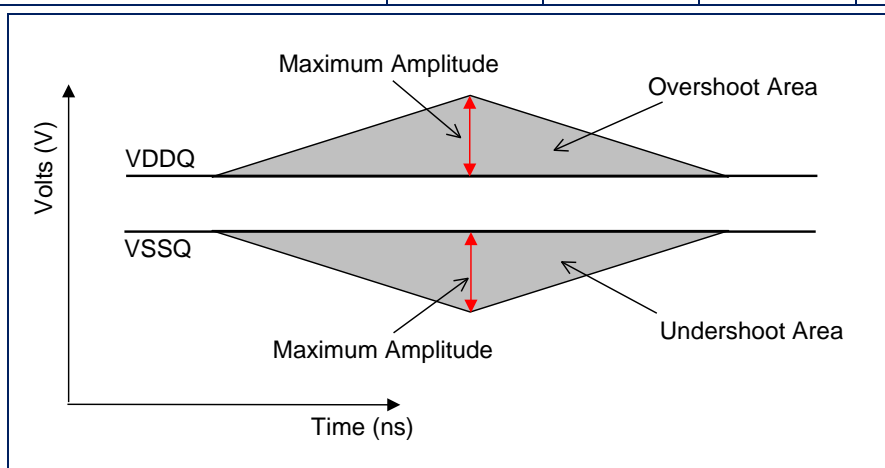

512Mb DDR2 SDRAM

Package Dimensions

(x4/x8; 60 balls; BGA Package)

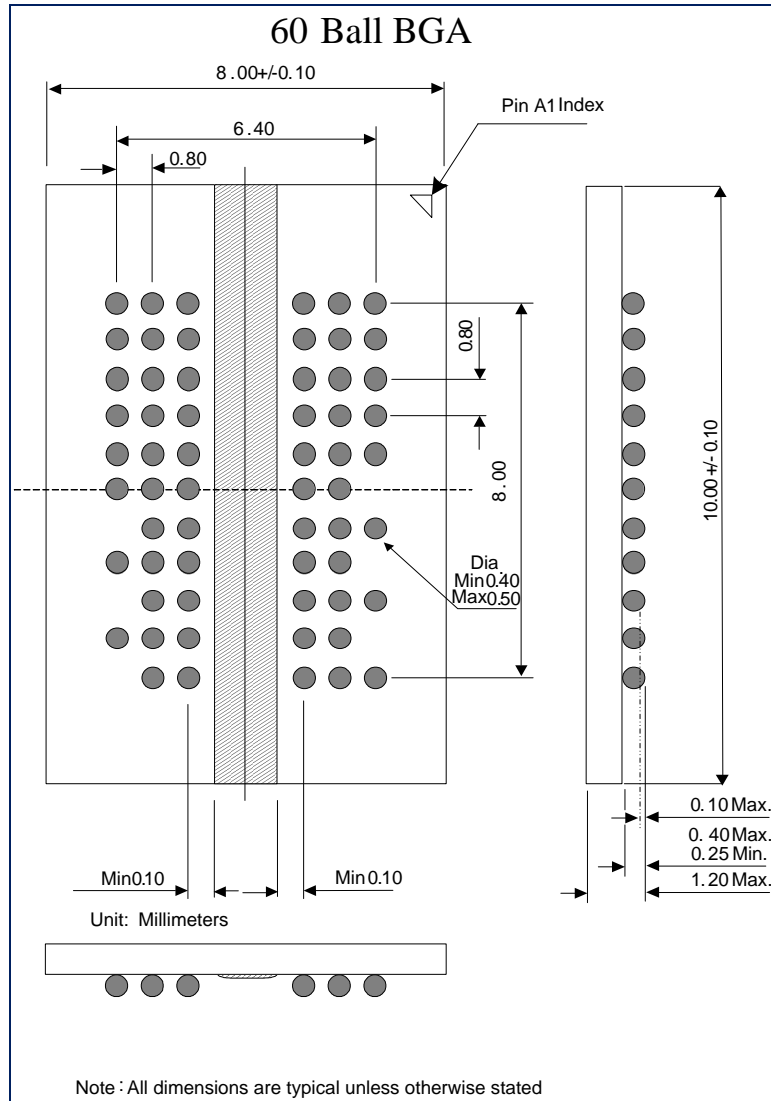

512Mb DDR2 SDRAM

Package Dimensions

(X16; 84 balls; BGA Package)

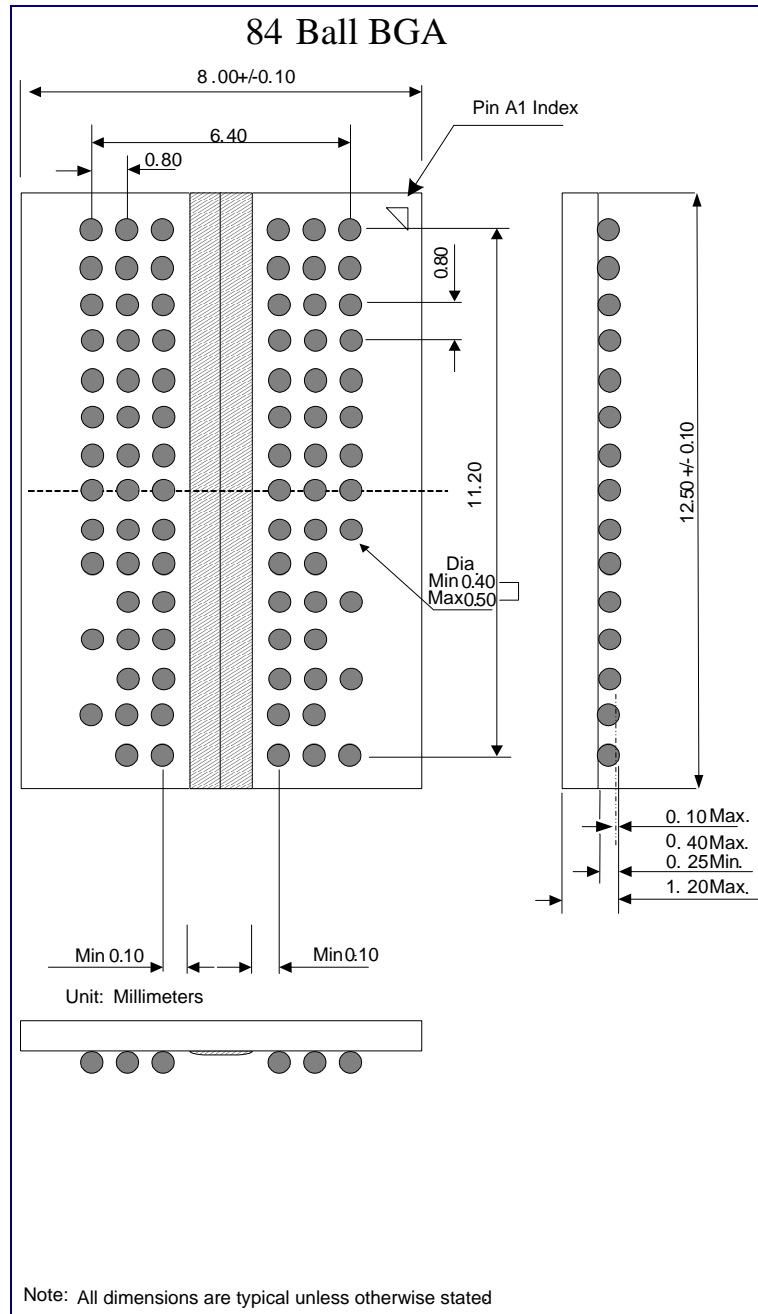

512Mb DDR2 SDRAM

Revision Log

Rev	Date	Modification
0.1	06/2010	Preliminary Release
0.2	07/2010	Revised Block Diagram Description
0.3	09/2010	Revised Description, Electrical Characteristics, tFAW, the feature of –BE, and ordering information
0.4	09/2010	Revised tRRD
0.5	10/2010	Updated CAS Latency Frequency Table
0.6	11/2010	Revised Refresh Parameter Component Type
1.0	12/2010	Official Release
1.1	02/2011	Revised 60 balls BGA Package Pin Configuration and –BD tCK parameters
1.2	04/2011	Removed x8/1066 Part Number from Ordering Information
1.3	05/2011	Revised Note Description of Operating Temperature Range and Table of Bank Selection for Prechange by Address Bit
1.4	08/2011	Revised the number bit of address bus
1.5	12/2011	Added Tc and T _{OPER} relation into the description of Operating Temperature
1.6	12/2011	Revised Self Refresh Exit in the Command Truth Table
1.7	07/2012	Added General Note and Specific Note from the page 75 to the page 87
1.8	02/2013	Modified tRAS.