

8 Megabit Serial Flash Memory with 4Kbytes Uniform Sector

ZD25D80

FEATURES

Single power supply operation

- Full voltage range: 2.7-3.6 volt

8 Mbit Serial Flash

- 8 M-bit/1024 K-byte/4096 pages
- 256 bytes per programmable page
- Uniform 4K-byte Sectors/64K-byte Blocks

Standard and Dual

- Standard SPI: CLK, CS#, DI, DO, WP#,
- Dual SPI: CLK, CS#, DIO, DO, WP#,
- Fast Read Dual Output instruction
- Auto-increment Read capability

High performance

- 85MHz clock rate for one data bit
- 80MHz clock rate for two data bits

Low power consumption

- 9 mA typical active current
- 1 uA typical power down current

Flexible Architecture with 4KB sectors

- Sector Erase (4K-bytes)
- Block Erase (64K-bytes)
- Page Program up to 256 bytes
- More than 100K erase/write cycles
- More than 20-year data retention

Software and Hardware Write Protection:

- Write Protect all or portion of memory via software
- Enable/Disable protection with WP# pin

High performance program/erase speed

- Page program time: 0.9ms typical
- Sector erase time: 50ms typical
- Block erase time: 300ms typical
- Chip erase time: 5 Seconds typical

Package Options

- 8-pin SOIC 150/208-mil
- USON8 (3*2mm)
- USON8 (3*3mm)
- WSON8 (6*5mm)
- All Pb-free packages are RoHS compliant

GENERAL DESCRIPTION

The ZD25D80 is a 8 Megabit (1024K-byte) Serial Flash memory, with advanced write protection mechanisms. The ZD25D80 supports the standard Serial Peripheral Interface (SPI), and a high performance Dual output using SPI pins: Serial Clock, Chip Select, Serial DIO, DO, WP#. SPI clock frequencies of up to 85MHz are supported allowing equivalent clock rates of 80MHz for Dual Output. The memory can be programmed 1 to 256 bytes at a time, using the Page Program instruction.

The ZD25D80 also offers a sophisticated method for protecting individual blocks against erroneous or malicious program and erase operations. By providing the ability to individually protect and unprotect blocks, a system can unprotect a specific block to modify its contents while keeping the remaining blocks of the memory array securely protected. This is useful in applications where program code is patched or updated on a subroutine or module basis, or in applications where data storage segments need to be modified without running the risk of errant modifications to the program code segments.

The ZD25D80 is designed to allow either single Sector/Block at a time or full chip erase operation. The ZD25D80 can be configured to protect part of the memory as the software protected mode. The device can sustain a minimum of 100K program/erase cycles on each sector or block.

1. ORDERING INFORMATION

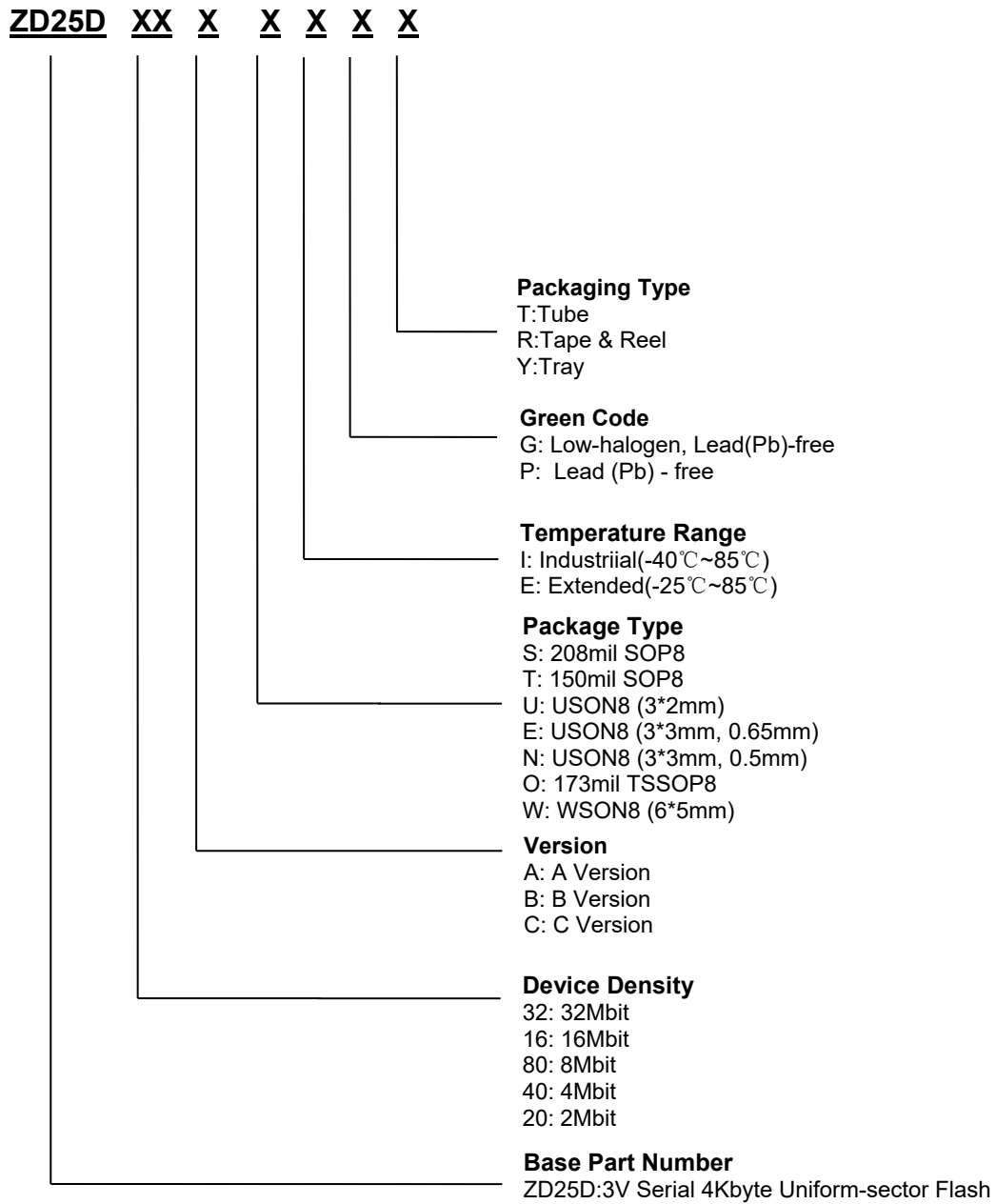

Figure 1, Ordering Information

2. BLOCK DIAGRAM

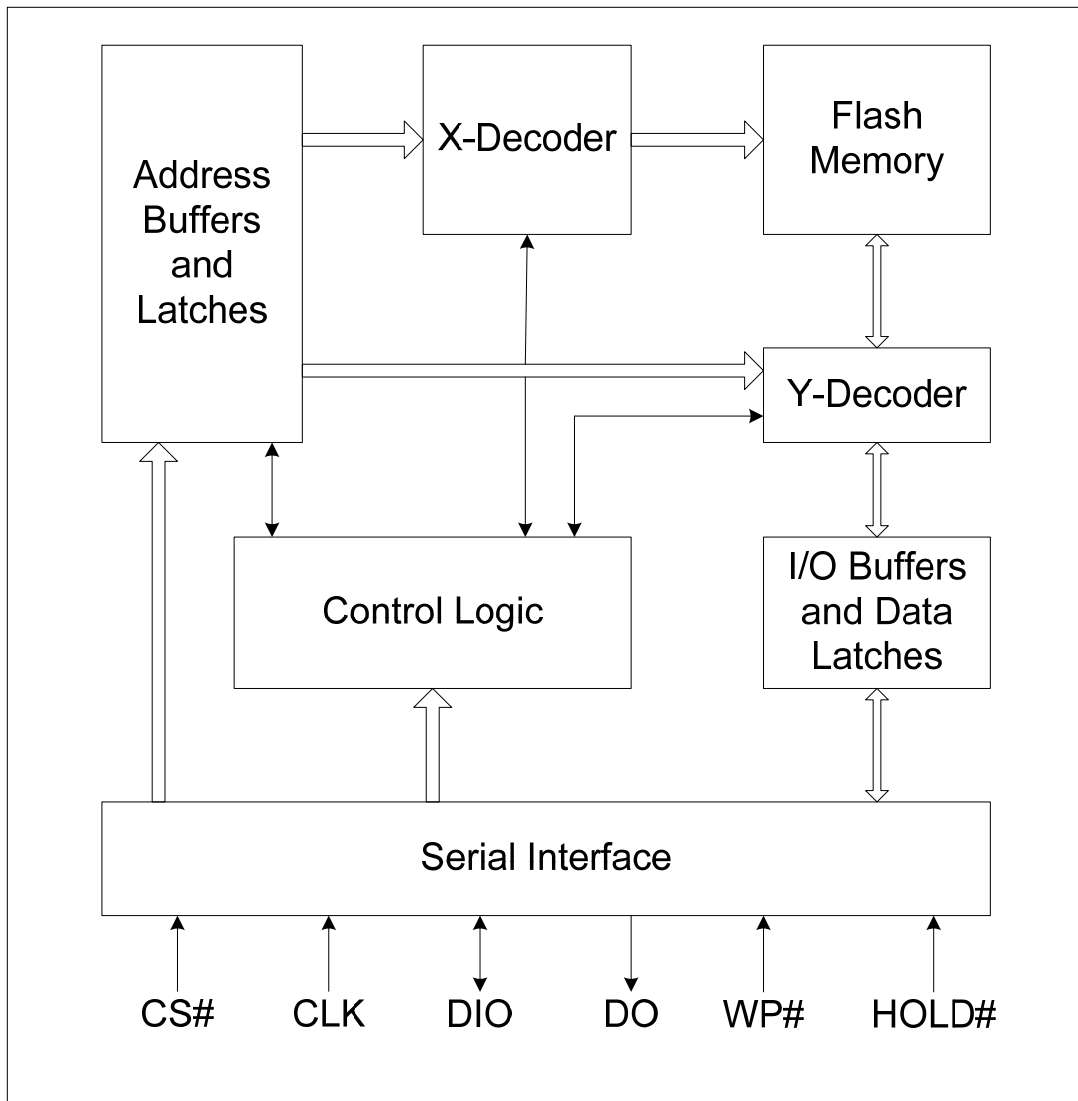

Figure 2, Block Diagram

3. CONNECTION DIAGRAMS

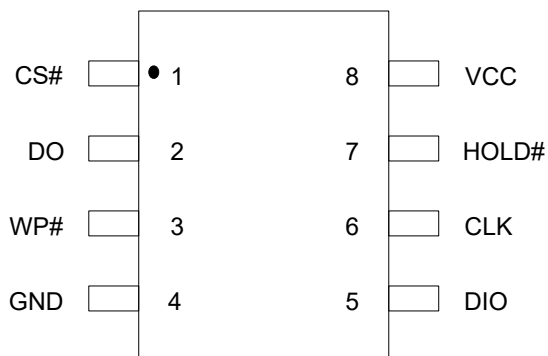

Figure 3.1, 8-pin SOP (150/208mil)/ PDIP (300mil)

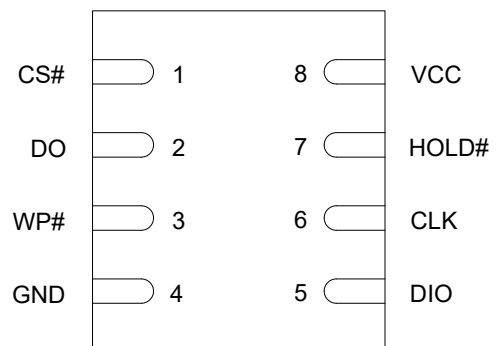

Figure 3.2, 8-Contact 6 x 5 mm WSON

4. SIGNAL DESCRIPTIONS

Serial Data Input / Output (DIO)

The SPI Serial Data Input/Output (DIO) pin provides a means for instructions, addresses and data to be serially written to (shifted into) the device. Data is latched on the rising edge of the Serial Clock (CLK) input pin. The DIO pin is also used as an output pin when the Fast Read Dual Output instruction is executed.

Serial Data Output (DO)

The SPI Serial Data Output (DO) pin provides a means for data and status to be serially read from (shifted out of) the device. Data is shifted out on the falling edge of the Serial Clock (CLK) input pin.

Serial Clock (CLK)

The SPI Serial Clock Input (CLK) pin provides the timing for serial input and output operations. ("See SPI Mode")

Chip Select (CS#)

The SPI Chip Select (CS#) pin enables and disables device operation. When CS# is high the device is deselected and the Serial Data Output pins are at high impedance.

When deselected, the devices power consumption will be at standby levels unless an internal erase, program or status register cycle is in progress. When CS# is brought low the device will be selected, power consumption will increase to active levels and instructions can be written to and data read from the device. After power-up, CS# must transition from high to low before a new instruction will be accepted.

Write Protect (WP#)

The Write Protect (WP#) pin can be used to prevent the Status Register from being written. Used in conjunction with the Status Register's Block Protect (BP0, BP1 and BP2, BP3) bits and Status Register Protect (SRP) bits, a portion or the entire memory array can be hardware protected.

Table1, Pin Descriptions

Symbol	Pin Name
CLK	Serial Clock Input
DIO	Serial Data Input / Output (Note 1)
DO	Serial Data Output
CS#	Chip Enable
WP#	Write Protect
VCC	Supply Voltage (2.7-3.6V)
GND	Ground

Note 1: DIO output is used for Dual instructions.

5. MEMORY ORGANIZATIONS

The memory is organized as:

- 1,048,576 bytes
- Uniform Sector Architecture
- 16 blocks of 64-Kbyte
- 256 sectors of 4-Kbyte
- 4,096 pages (256 bytes each)

Each page can be individually programmed (bits are programmed from 1 to 0). The device is Sector, Block or Chip Erasable but not Page Erasable.

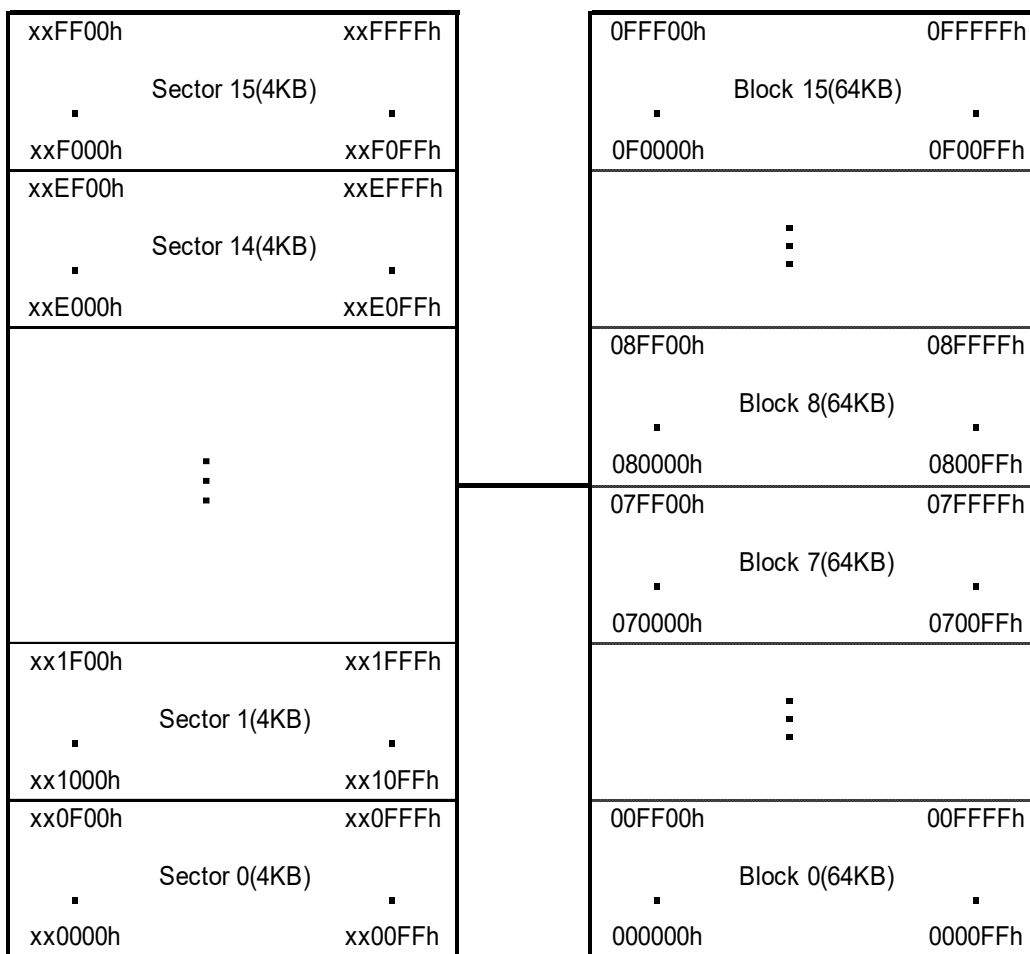

Figure 4, Memory Organization

6. FUNCTION DESCRIPTION

SPI Modes

The ZD25D80 are accessed through an SPI compatible bus consisting of four signals: Serial Clock (CLK), Chip Select (CS#), Serial Data Input / Output (DIO) and Serial Data Output (DO). Both SPI bus operation Modes 0 (0, 0) and 3 (1, 1) are supported. The primary difference between Mode 0 and Mode 3, as shown in Figure 5, concerns the normal state of the CLK signal when the SPI bus master is in standby and data is not being transferred to the Serial Flash. For Mode 0 the CLK is normally low. For Mode 3 the CLK is normally high. In either case data input on the DIO pin is sampled on the rising edge of the CLK. Data on the DO and DIO pins are clocked out on the falling edge of CLK.

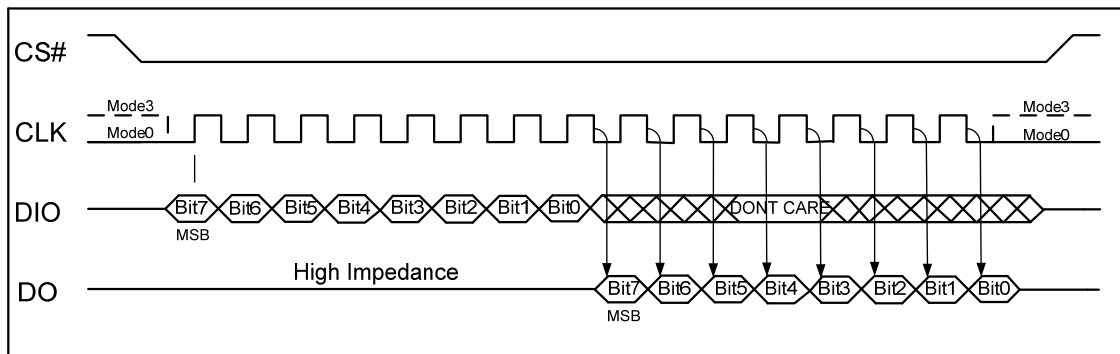

Figure 5, SPI Modes

Dual Output SPI

The ZD25D80 supports Dual Output Operation when using the “Fast Read with Dual Output” (3B hex) instruction. This feature allows data to be transferred from the Serial Flash at twice the rate possible with the standard SPI. This instruction is ideal for quickly downloading code from Flash to RAM upon Power-up (Code-shadowing) or for applications that cache code-segments to RAM for execution. The Dual Output feature simply allows the SPI input pin to also serve as an output during this instruction. All other operations use the standard SPI interface with single signal.

Status Register

The Status Register contains a number of status and control bits that can be read or set (as appropriate) by specific instructions.

Table 2, Status Register Bit Locations

R7	R6	R5	R4	R3	R2	R1	R0
SRP	Reserved	BP3	BP2	BP1	BP0	WEL	BUSY

- BUSY** is a read only bit in the status register (R0) that is set to a 1 state when the device is executing a Page Program, Sector Erase, Block Erase, Chip Erase or Write Status Register instruction. During this time the device will ignore further instructions except for the Read Status Register instruction (see tW, tPP, tSE, tBE, and tCE in AC Characteristics). When the program, erase or write status register instruction has completed, the BUSY bit will be cleared to a 0 state indicating the device is ready for further instructions.
- Write Enable Latch (WEL)** is a read only bit in the status register (R1) that is set to a 1 after executing a Write Enable Instruction. The WEL status bit is cleared to a 0 when the device is write disabled. A write disable state occurs upon power-up or after any of the following instructions: Write Disable, Page Program, Sector Erase, Block Erase, Chip Erase and Write Status Register.
- Block Protect Bits (BP3, BP2, BP1, BP0)** are non-volatile read/write bits in the status register (R5, R4, R3 and R2) that provide Write Protection control and status. Block Protect bits can be set using the Write Status Register Instruction (see tW in AC characteristics). All, none or a portion of the memory array can be protected from Program and Erase instructions (see Status Register Memory Protection table). The factory default setting for the Block Protection Bits is 0, none of the array protected. The Block Protect bits can not be written to if the Status Register Protect (SRP) bit is set to 1 and the Write Protect (W/P) pin is low.

- **The Status Register Protect (SRP)** bit is a non-volatile read/write bit in status register (R7) that can be used in conjunction with the Write Protect (/WP) pin to disable writes to status register. When the SRP bit is set to a 0 state (factory default) the /WP pin has no control over status register. When the SRP pin is set to a 1, the Write Status Register instruction is locked out while the /WP pin is low. When the /WP pin is high the Write Status Register instruction is allowed.

Write Protection

Applications that use non-volatile memory must take into consideration the possibility of noise and other adverse system conditions that may compromise data integrity. To address this concern the ZD25D80 provide the following data protection mechanisms:

- Power-On Reset and an internal timer (t_{PUW}) can provide protection against inadvertent changes while the power supply is outside the operating specification.
- Program, Erase and Write Status Register instructions are checked that they consist of a number of clock pulses that is a multiple of eight, before they are accepted for execution.
- All instructions that modify data must be preceded by a Write Enable (WREN) instruction to set the Write Enable Latch (WEL) bit . This bit is returned to its reset state by the following events:
 - Power-up
 - Write Disable (WRDI) instruction completion or Write Status Register (WRSR) instruction completion or Page Program (PP) instruction completion or Sector Erase (SE) instruction completion or Block Erase (BE) instruction completion or Chip Erase (CE) instruction completion
- The Block Protect (BP3, BP2, BP1, and BP0) bits allow part of the memory to be configured as read-only. This is the Software Protected Mode (SPM).
- The Write Protect (WP#) signal allows the Block Protect (BP3, BP2, BP1, BP0) bits and Status Register Protect (SRP) bit to be protected. This is the Hardware Protected Mode (HPM).
- In addition to the low power consumption feature, the Deep Power-down mode offers extra software protection from inadvertent Write, Program and Erase instructions, as all instructions are ignored except one particular instruction (the Release from Deep Power-down instruction).

Table 3, Protected Area Sizes Block Organization

Status Bit				ZD25D80 (8Mb) Block Protection
BP3	BP2	BP1	BP0	Protect Level
0	0	0	0	0 (None)
0	0	0	1	1 (1 block, block 15th)
0	0	1	0	2 (2 blocks, block 14th - 15th)
0	0	1	1	3 (4 blocks, block 12th - 15th)
0	1	0	0	4 (8 blocks, block 8th - 15th)
0	1	0	1	5 (16 blocks, ALL)
0	1	1	0	6 (16 blocks, ALL)
0	1	1	1	7 (16 blocks, ALL)
1	0	0	0	8 (None)
1	0	0	1	9 (254 sectors, sector 0th - 253th)
1	0	1	0	10 (252 sectors, sector 0th - 251th)
1	0	1	1	11 (248 sectors, sector 0th - 247th)
1	1	0	0	12 (240 sectors, sector 0th - 239th)
1	1	0	1	13 (224 sectors, sector 0th - 223th)
1	1	1	0	14 (192 sectors, sector 0th - 191th)
1	1	1	1	15 (256 sectors, all)

Page Programming

To program one data byte, two instructions are required: Write Enable (WREN), which is one byte, and a Page Program (PP) sequence, which consists of four bytes plus data. This is followed by the internal Program cycle (of duration t_{PP}). To spread this overhead, the Page Program (PP) instruction allows up to 256 bytes to be programmed at a time (changing bits from 1 to 0), provided that they lie in consecutive addresses on the same page of memory.

Sector Erase, Block Erase and Chip Erase

The Page Program (PP) instruction allows bits to be reset from 1 to 0. Before this can be applied, the bytes of memory need to have been erased to all 1s (FFh). This can be achieved a sector at a time, using the Sector Erase (SE) instruction, a block at a time using the Block Erase (BE) instruction or throughout the entire memory, using the Chip Erase (CE) instruction. This starts an internal Erase cycle (of duration t_{SE} , t_{BE} or t_{CE}). The Erase instruction must be preceded by a Write Enable (WREN) instruction.

Polling During a Write, Program or Erase Cycle

A further improvement in the time to Write Status Register (WRSR), Program (PP) or Erase (SE, BE or CE) can be achieved by not waiting for the worst case delay (t_w , t_{PP} , t_{SE} , t_{BE} or t_{CE}). The Write In Progress (WIP) bit is provided in the Status Register so that the application program can monitor its value, polling it to establish when the previous Write cycle, Program cycle or Erase cycle is complete.

Active Power, Stand-by Power and Deep Power-Down Modes

When Chip Select (CS#) is Low, the device is enabled, and in the Active Power mode. When Chip Select (CS#) is High, the device is disabled, but could remain in the Active Power mode until all internal cycles have completed (Program, Erase, Write Status Register). The device then goes into the Standby Power mode. The device consumption drops to I_{CC1} .

The Deep Power-down mode is entered when the specific instruction (the Enter Deep Power-down Mode (DP) instruction) is executed. The device consumption drops further to I_{CC2} . The device remains in this mode until another specific instruction (the Release from Deep Power-down Mode and Read Device ID (RDI) instruction) is executed.

All other instructions are ignored while the device is in the Deep Power-down mode. This can be used as an extra software protection mechanism, when the device is not in active use, to protect the device from inadvertent Write, Program or Erase instructions.

7 INSTRUCTIONS

The instruction set of the ZD25D80 consists of fifteen basic instructions that are fully controlled through the SPI bus (see Instruction Set table). Instructions are initiated with the falling edge of Chip Select (CS#). The first byte of data clocked into the DIO input provides the instruction code. Data on the DIO input is sampled on the rising edge of clock with most significant bit (MSB) first.

Instructions vary in length from a single byte to several bytes and may be followed by address bytes, data bytes, dummy bytes (don't care), and in some cases, a combination. Instructions are completed with the rising edge of edge CS#. Clock relative timing diagrams for each instruction are included in figures 7 through 22. All read instructions can be completed after any clocked bit. However, all instructions that Write, Program or Erase must complete on a byte boundary (CS driven high after a full 8-bits have been clocked) otherwise the instruction will be terminated. This feature further protects the device from inadvertent writes. Additionally, while the memory is being programmed or erased, or when the Status Register is being written, all instructions except for Read Status Register will be ignored until the program or erase cycle has completed.

Table 4, Instruction Set

INSTRUCTION NAME	BYTE1 CODE	BYTE2	BYTE3	BYTE4	BYTE5	BYTE6	N-BYTES
Write Enable	06h						
write Disable	04h						
Read Status Register	05h	(S7-S0) ⁽¹⁾					(2)
Write Status Register	01h	S7-S0					
Read Data	03h	A23-A16	A15-A8	A7-A0	(D7-D0)	(Next byte)	continuous
Fast Read	0Bh	A23-A16	A15-A8	A7-A0	dummy	(D7-D0)	(Next byte) continuous
Fast Read Dual Output	3Bh	A23-A16	A15-A8	A7-A0	dummy	I/O= (D6,D4,D2,D0) O= (D7,D5,D3,D1)	(One byte per 4 clocks, continuous)
Page Program	02h	A23-A16	A15-A8	A7-A0	(D7-D0)	(Next byte)	Up to 256 bytes
Block Erase(64KB)	D8h	A23-A16	A15-A8	A7-A0			
Half Block Erase(32KB)	52h	A23-A16	A15-A8	A7-A0			
Sector Erase(4KB)	20h	A23-A16	A15-A8	A7-A0			
Chip Erase	C7h/60h						
Power-down	B9h						
Release Power-down /Device ID	ABh	dummy	dummy	dummy	(ID7-ID0) ⁽⁴⁾		
Manufacturer /Device ID ⁽³⁾	90h	dummy	dummy	00h	(M7-M0)	(ID7-ID0)	
JEDEC ID	9Fh	(M7-M0) manufacturer	(ID15-ID8) Memory Type	(ID7-ID0) Capacity			

Notes:

1. Data bytes are shifted with Most Significant Bit first. Byte fields with data in parenthesis "()" indicate data being read from the device on the DO pin.
2. The Status Register contents will repeat continuously until CS# terminates the instruction.
3. See Manufacturer and Device Identification table for Device ID information.
4. The Device ID will repeat continuously until CS# terminates the instruction.

Table 5, Manufacturer and Device Identification

OP Code	(M7-M0)	(ID15-ID0)	(ID7-ID0)
ABh			13h
90h	BAh		13h
9Fh	BAh	2014h	

Write Enable (06h)

The Write Enable instruction (Figure 7) sets the Write Enable Latch (WEL) bit in the Status Register to a 1. The WEL bit must be set prior to every Page Program, Sector Erase, Block Erase, Chip Erase and Write Status Register instruction. The Write Enable instruction is entered by driving CS# low, shifting the instruction code “06h” into the Data Input (DI) pin on the rising edge of CLK, and then driving CS# high.

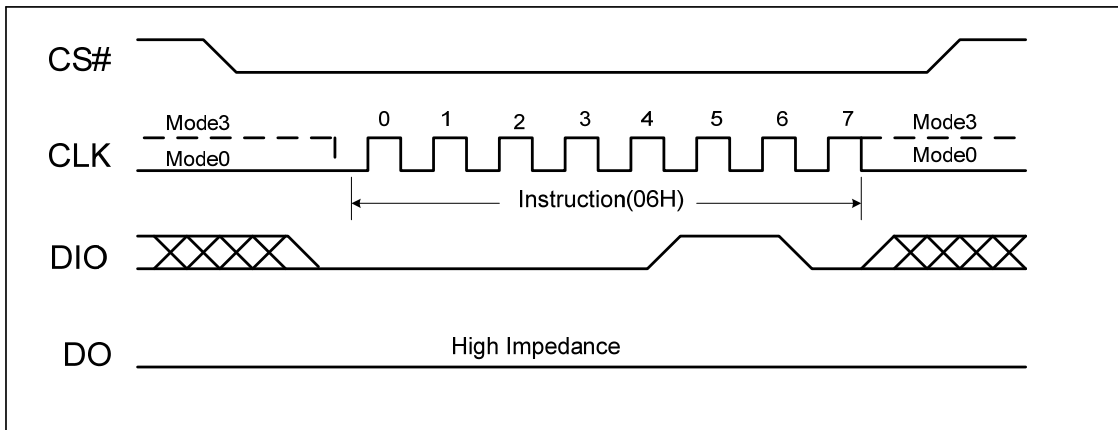

Figure 7, Write Enable Instruction Sequence Diagram

Write Disable (04h)

The Write Disable instruction (Figure 8) resets the Write Enable Latch (WEL) bit in the Status Register to a 0. The Write Disable instruction is entered by driving CS# low, shifting the instruction code “04h” into the DIO pin and then driving CS# high. Note that the WEL bit is automatically reset after Power-up and upon completion of the Write Status Register, Page Program, Sector Erase, Block Erase and Chip Erase instructions.

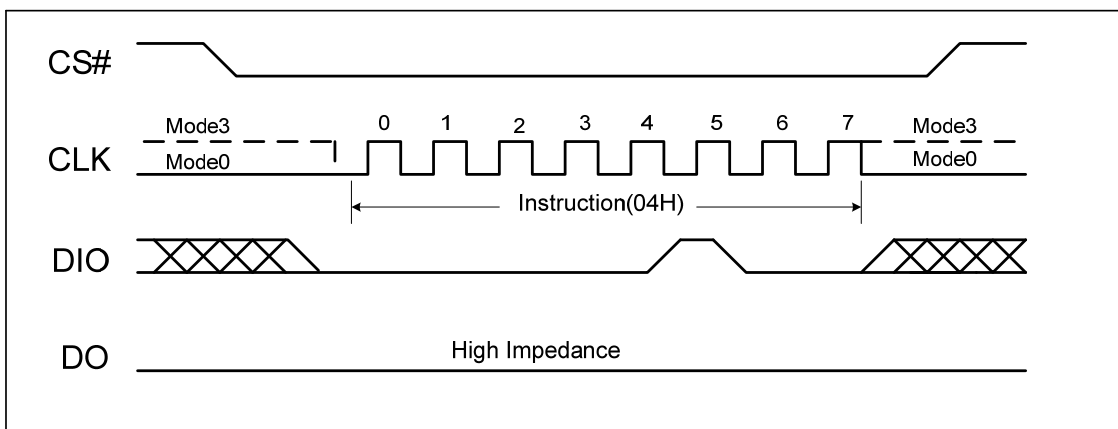

Figure 8, Write Disable Instruction Sequence Diagram

Read Status Register (05h)

The Read Status Register instruction allows the 8-bit Status Register to be read. The instruction is entered by driving CS# low and shifting the instruction code "05h" into the DIO pin on the rising edge of CLK. The status register bits are then shifted out on the DO pin at the falling edge of CLK with most significant bit (MSB) first as shown in figure 9. The Status Register bits are shown in figure 3 and include the BUSY, WEL, BP3-BP0, TB and SRP bits (see description of the Status Register earlier in this datasheet).

The Read Status Register instruction may be used at any time, even while a Program, Erase or Write Status Register cycle is in progress. This allows the BUSY status bit to be checked to determine when the cycle is complete and if the device can accept another instruction. The Status Register can be read continuously, as shown in Figure 9. The instruction is completed by driving CS# high.

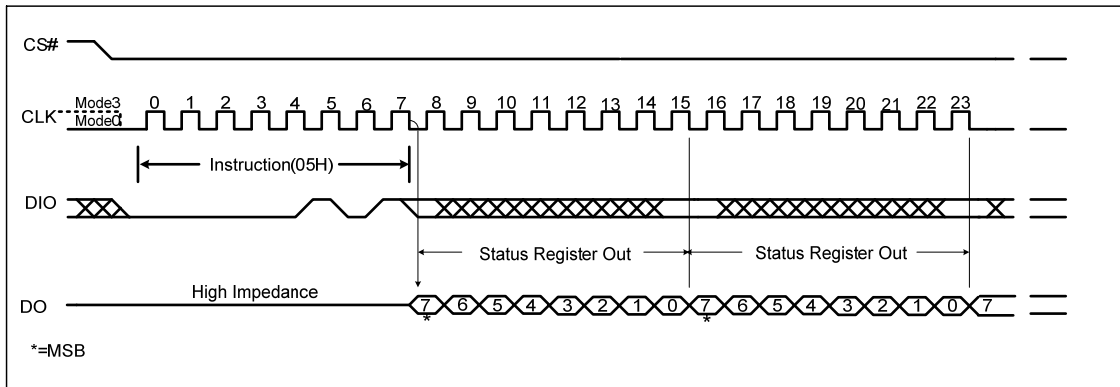

Figure 9, Read Status Register Instruction Sequence Diagram

Write Status Register (01h)

The Write Status Register instruction allows the Status Register to be written. A Write Enable instruction must previously have been executed for the device to accept the Write Status Register Instruction (Status Register bit WEL must equal 1). Once write enabled, the instruction is entered by driving CS# low, sending the instruction code "01h", and then writing the status register data byte as illustrated in figure 10. The Status Register bits are shown in figure 3 and described earlier in this datasheet.

Only non-volatile Status Register bits SRP, BP3, BP2, BP1 and BP0 (bits 7, 5, 4, 3 and 2) can be written to. All other Status Register bit locations are read-only and will not be affected by the Write Status Register instruction.

The CS# pin must be driven high after the eighth bit of the last byte has been latched. If this is not done the Write Status Register instruction will not be executed. After CS# is driven high, the self-timed Write Status Register cycle will commence for a time duration of t_W (See AC Characteristics). While the Write Status Register cycle is in progress, the Read Status Register instruction may still be accessed to check the status of the BUSY bit. The BUSY bit is a 1 during the Write Status Register cycle and a 0 when the cycle is finished and ready to accept other instructions again. After the Write Status Register cycle has finished the Write Enable Latch (WEL) bit in the Status Register will be cleared to 0.

The Write Status Register instruction allows the Block Protect bits (BP3, BP2, BP1 and BP0) to be set for protecting all, a portion, or none of the memory from erase and program instructions. Protected areas become read-only (see Status Register Memory Protection table). The Write Status Register instruction also allows the Status Register Protect bit (SRP) to be set. This bit is used in conjunction with the Write Protect (/WP) pin to disable writes to the status register. When the SRP bit is set to a 0 state (factory default) the /WP pin has no control over the status register. When the SRP pin is set to a 1, the Write Status Register instruction is locked out while the /WP pin is low. When the /WP pin is high the Write Status Register instruction is allowed.

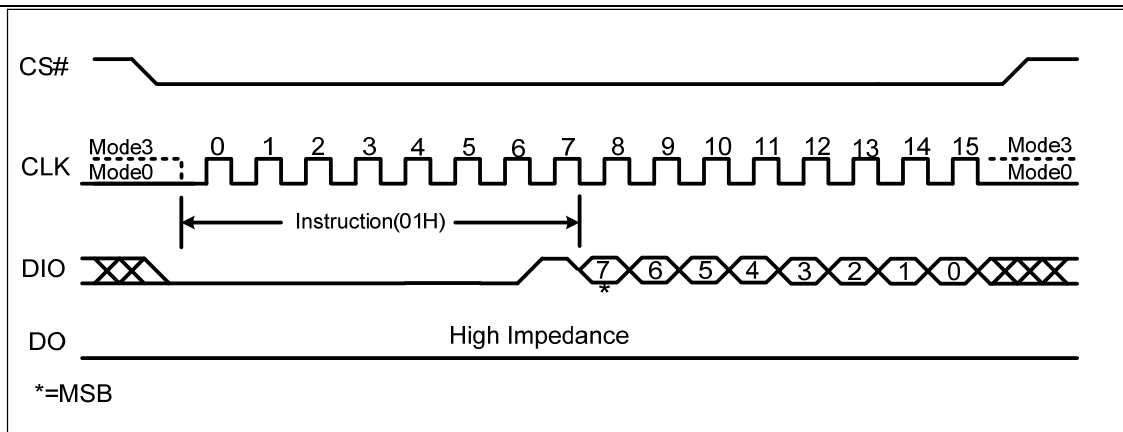

Figure 10, Write Status Register Instruction Sequence Diagram

Read Data (Read) (03h)

The Read Data instruction allows one more data bytes to be sequentially read from the memory. The instruction is initiated by driving the CS# pin low and then shifting the instruction code “03h” followed by a 24-bit address (A23-A0) into the DIO pin. The code and address bits are latched on the rising edge of the CLK pin. After the address is received, the data byte of the addressed memory location will be shifted out on the DO pin at the falling edge of CLK with most significant bit (MSB) first. The address is automatically incremented to the next higher address after each byte of data is shifted out allowing for a continuous stream of data. This means that the entire memory can be accessed with a single instruction as long as the clock continues. The instruction is completed by driving CS# high.

The Read Data instruction sequence is shown in figure 11. If a Read Data instruction is issued while an Erase, Program or Write cycle is in process (BUSY=1) the instruction is ignored and will not have any effects on the current cycle. The Read Data instruction allows clock rates from D.C. to a maximum of fR (see AC Electrical Characteristics).

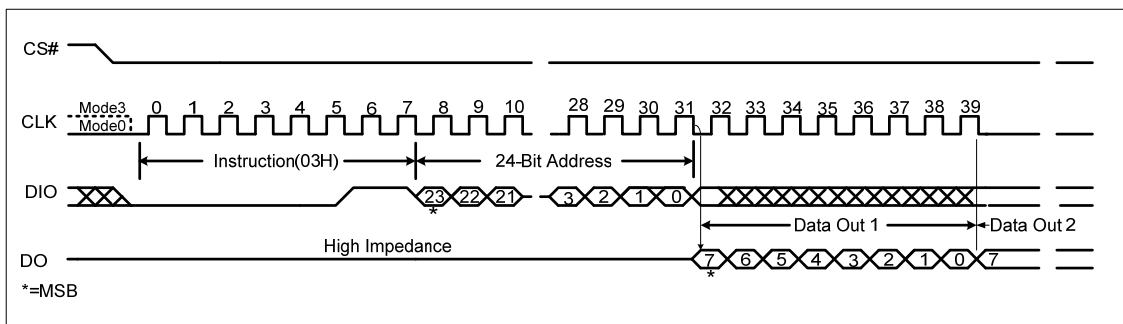

Figure 11. Read Data Instruction Sequence Diagram

Fast Read (0Bh)

The Fast Read instruction is similar to the Read Data instruction except that it can operate at the highest possible frequency of FR (see AC Electrical Characteristics). This is accomplished by adding eight “dummy” clocks after the 24-bit address as shown in figure 12. The dummy clocks allow the devices internal circuits additional time for setting up the initial address. During the dummy clocks the data value on the DIO pin is a “don't care”.

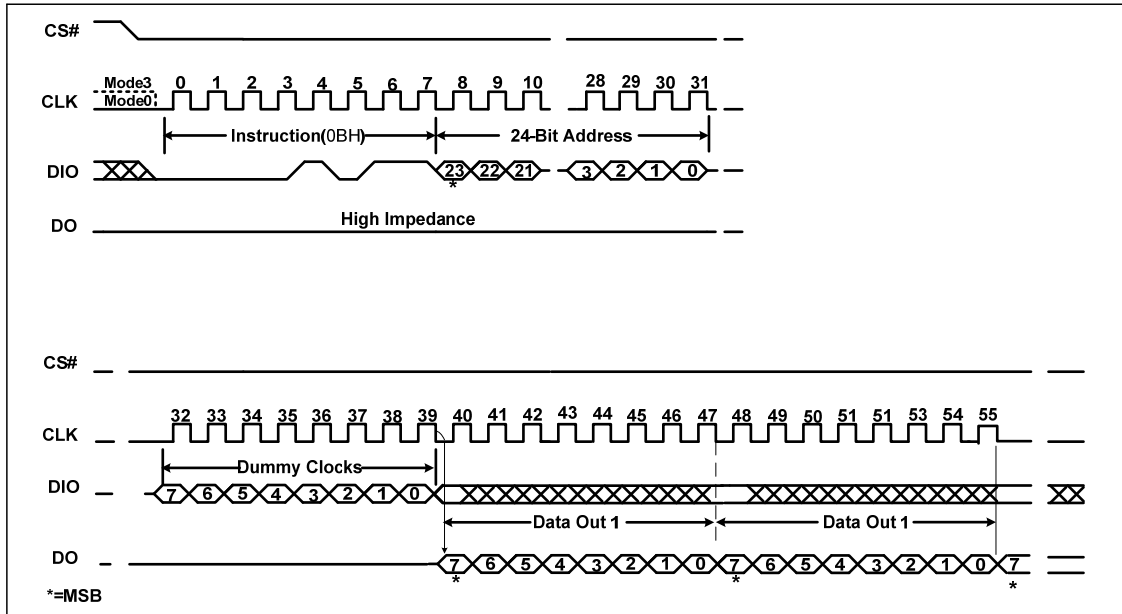

Figure 12, Fast Read Instruction Sequence Diagram

Fast Read Dual Output (3Bh)

The Fast Read Dual Output (3Bh) instruction is similar to the standard Fast Read (0Bh) instruction except that data is output on two pins, DO and DIO, instead of just DO. This allows data to be transferred from the ZD25D80 at twice the rate of standard SPI devices. The Fast Read Dual Output instruction is ideal for quickly downloading code from Flash to RAM upon power-up or for applications that cache code-segments to RAM for execution.

Similar to the Fast Read instruction, the Fast Read Dual Output instruction can operate at the highest possible frequency of FR (see AC Electrical Characteristics). This is accomplished by adding eight “dummy” clocks after the 24-bit address as shown in figure 13. The dummy clocks allow the device's internal circuits additional time for setting up the initial address. The input data during the dummy clocks is “don't care”. However, the DIO pin should be high-impedance prior to the falling edge of the first data out clock.

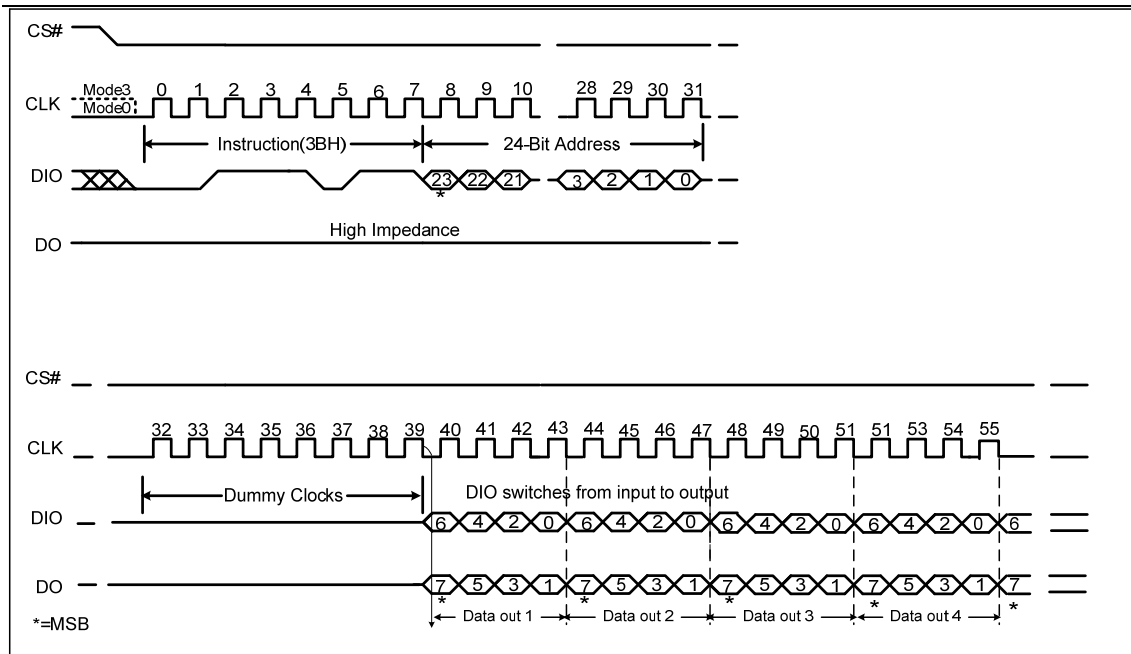

Figure 13, Fast Read Dual Output Instruction Sequence Diagram

Page Program (PP) (02h)

The Page Program instruction allows up to 256 bytes of data to be programmed at previously erased to all 1s (FFh) memory locations. A Write Enable instruction must be executed before the device will accept the Page Program Instruction (Status Register bit WEL must equal 1). The instruction is initiated by driving the CS# pin low then shifting the instruction code “02h” followed by a 24-bit address (A23-A0) and at least one data byte, into the DIO pin. The CS# pin must be held low for the entire length of the instruction while data is being sent to the device. The Page Program instruction sequence is shown in figure 14.

If an entire 256 byte page is to be programmed, the last address byte (the 8 least significant address bits) should be set to 0. If the last address byte is not zero, and the number of clocks exceed the remaining page length, the addressing will wrap to the beginning of the page. In some cases, less than 256 bytes (a partial page) can be programmed without having any effect on other bytes within the same page. One condition to perform a partial page program is that the number of clocks can not exceed the remaining page length. If more than 256 bytes are sent to the device the addressing will wrap to the beginning of the page and overwrite previously sent data.

As with the write and erase instructions, the CS# pin must be driven high after the eighth bit of the last byte has been latched. If this is not done the Page Program instruction will not be executed. After CS# is driven high, the self-timed Page Program instruction will commence for a time duration of t_{pp} (See AC Characteristics). While the Page Program cycle is in progress, the Read Status Register instruction may still be accessed for checking the status of the BUSY bit. The BUSY bit is a 1 during the Page Program cycle and becomes a 0 when the cycle is finished and the device is ready to accept other instructions again. After the Page Program cycle has finished the Write Enable Latch (WEL) bit in the Status Register is cleared to 0. The Page Program instruction will not be executed if the addressed page is protected by the Block Protect (BP3, BP2, BP1, and BP0) bits (see Status Register Memory Protection table).

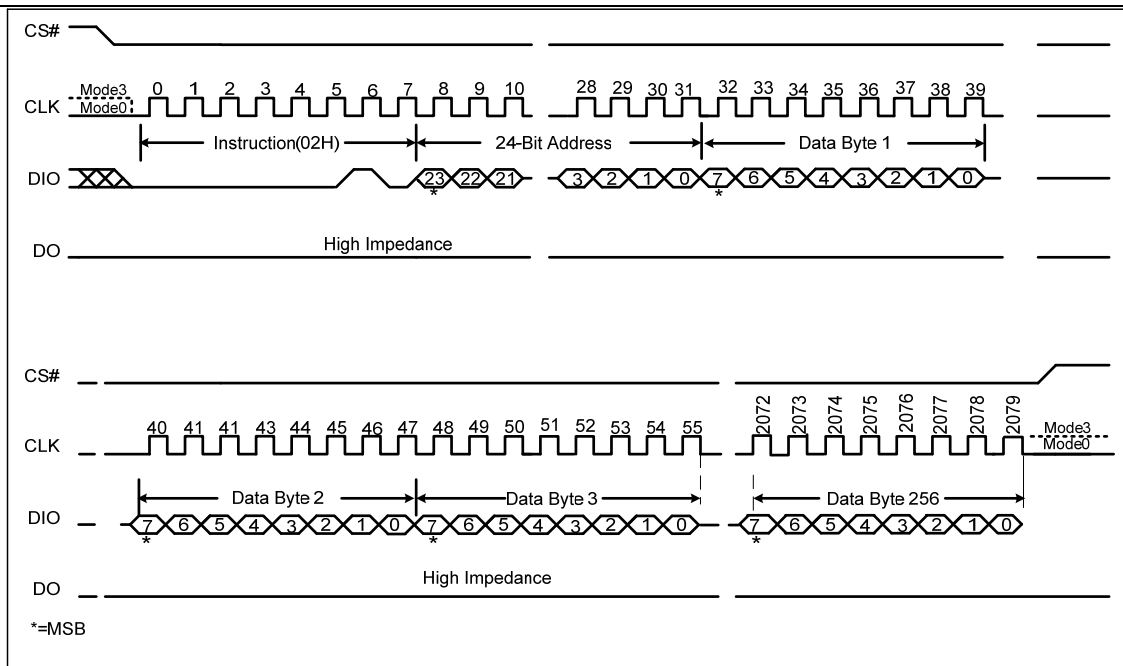

Figure 14, Page Program Instruction Sequence Diagram

Sector Erase (SE) (20h)

The Sector Erase instruction sets all memory within a specified sector (4K-bytes) to the erased state of all 1s (FFh). A Write Enable instruction must be executed before the device will accept the Sector Erase Instruction (Status Register bit WEL must equal 1). The instruction is initiated by driving the CS# pin low and shifting the instruction code “20h” followed a 24-bit sector address (A23-A0) (see Figure 2). The Sector Erase instruction sequence is shown in figure 15.

The CS# pin must be driven high after the eighth bit of the last byte has been latched. If this is not done the Sector Erase instruction will not be executed. After CS# is driven high, the self-timed Sector Erase instruction will commence for a time duration of tSE (See AC Characteristics). While the Sector Erase cycle is in progress, the Read Status Register instruction may still be accessed for checking the status of the BUSY bit. The BUSY bit is a 1 during the Sector Erase cycle and becomes a 0 when the cycle is finished and the device is ready to accept other instructions again. After the Sector Erase cycle has finished the Write Enable Latch (WEL) bit in the Status Register is cleared to 0. The Sector Erase instruction will not be executed if the addressed page is protected by the Block Protect (BP3, BP2, BP1, and BP0) bits (see Status Register Memory Protection table).

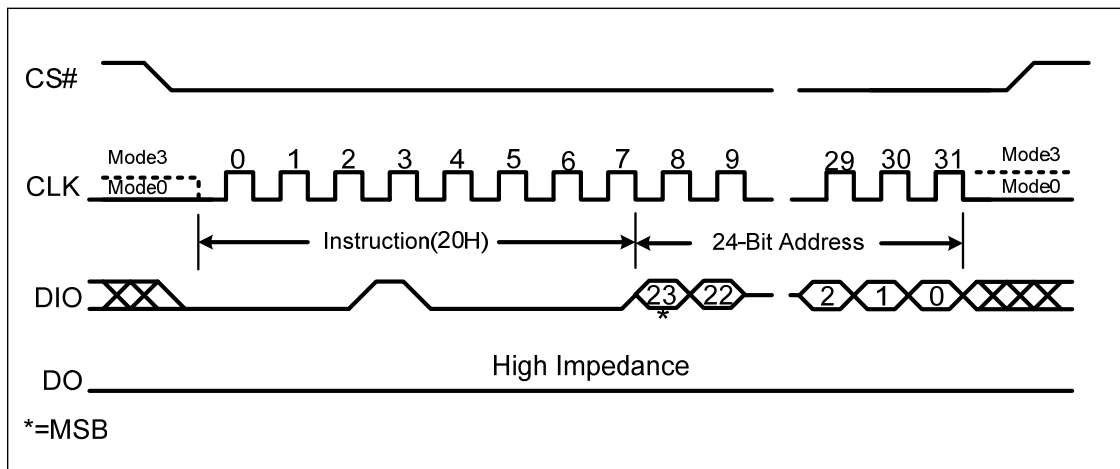

Figure 15, Sector Erase Instruction Sequence Diagram

Block Erase (BE) (D8h) and Half Block Erase (52h)

The Block Erase instruction sets all memory within a specified block (64K-bytes) or half block (32K-bytes) to the erased state of all 1s (FFh). A Write Enable instruction must be executed before the device will accept the Block Erase Instruction (Status Register bit WEL must equal 1). The instruction is initiated by driving the CS# pin low and shifting the instruction code “D8h” or “52h” followed a 24-bit block address (A23-A0) (see Figure 2). The Block Erase instruction sequence is shown in figure 16.

The CS# pin must be driven high after the eighth bit of the last byte has been latched. If this is not done the Block Erase instruction will not be executed. After CS# is driven high, the self-timed Block Erase instruction will commence for a time duration of tBE (See AC Characteristics). While the Block Erase cycle is in progress, the Read Status Register instruction may still be accessed for checking the status of the BUSY bit. The BUSY bit is a 1 during the Block Erase cycle and becomes a 0 when the cycle is finished and the device is ready to accept other instructions again. After the Block Erase cycle has finished the Write Enable Latch (WEL) bit in the Status Register is cleared to 0. The Block Erase instruction will not be executed if the addressed page is protected by the Block Protect (BP3, BP2, BP1, and BP0) bits (see Status Register Memory Protection table).

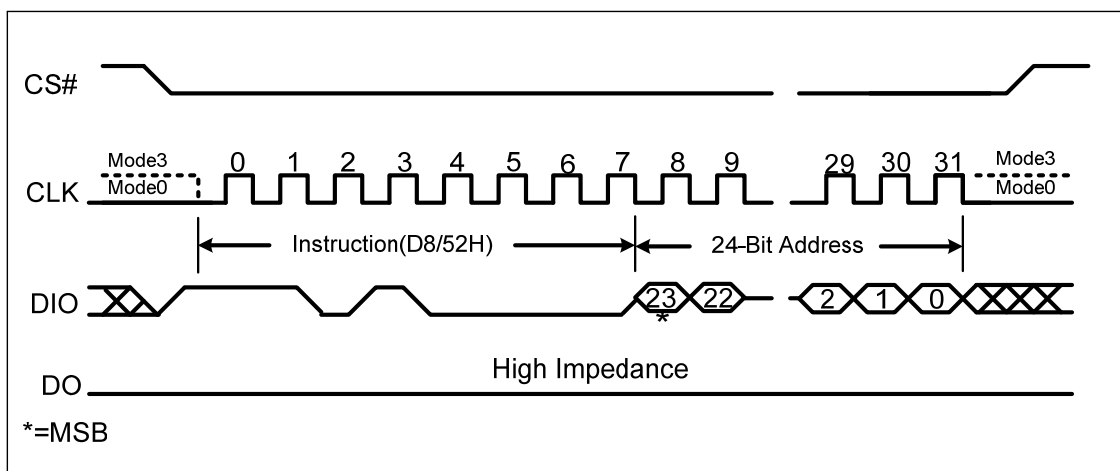

Figure 16. Block Erase Instruction Sequence Diagram

Chip Erase (CE) (C7h or 60h)

The Chip Erase instruction sets all memory within the device to the erased state of all 1s (FFh). A Write Enable instruction must be executed before the device will accept the Chip Erase Instruction (Status Register bit WEL must equal 1). The instruction is initiated by driving the CS# pin low and shifting the instruction code “C7h” or “60h”. The Chip Erase instruction sequence is shown in figure 17.

The CS# pin must be driven high after the eighth bit has been latched. If this is not done the Chip Erase instruction will not be executed. After CS# is driven high, the self-timed Chip Erase instruction will commence for a time duration of tCE (See AC Characteristics). While the Chip Erase cycle is in progress, the Read Status Register instruction may still be accessed to check the status of the BUSY bit. The BUSY bit is a 1 during the Chip Erase cycle and becomes a 0 when finished and the device is ready to accept other instructions again. After the Chip Erase cycle has finished the Write Enable Latch (WEL) bit in the Status Register is cleared to 0. The Chip Erase instruction will not be executed if any page is protected by the Block Protect (BP3, BP2, BP1, and BP0) bits (see Status Register Memory Protection table).

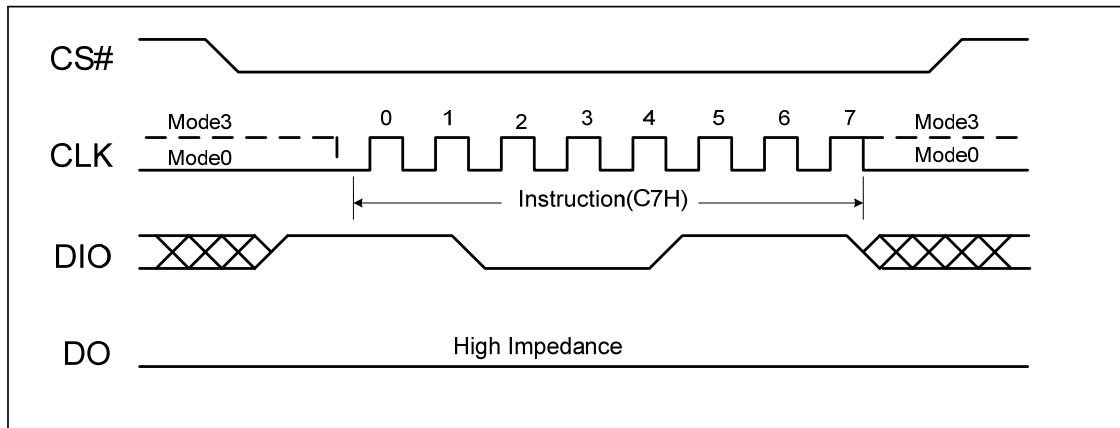

Figure 17, Chip Erase Instruction Sequence Diagram

Deep Power-down (DP) (B9h)

Although the standby current during normal operation is relatively low, standby current can be further reduced with the Power-down instruction. The lower power consumption makes the Power-down instruction especially useful for battery powered applications (See ICC1 and ICC2 in AC Characteristics). The instruction is initiated by driving the CS# pin low and shifting the instruction code “B9h” as shown in figure 18.

The CS# pin must be driven high after the eighth bit has been latched. If this is not done the Power-down instruction will not be executed. After CS# is driven high, the power-down state will enter within the time duration of t_{DP} (See AC Characteristics). While in the power-down state only the Release from Power-down / Device ID instruction, which restores the device to normal operation, will be recognized. All other instructions are ignored. This includes the Read Status Register instruction, which is always available during normal operation. Ignoring all but one instruction makes the Power Down state a useful condition for securing maximum write protection. The device always powers-up in the normal operation with the standby current of ICC1.

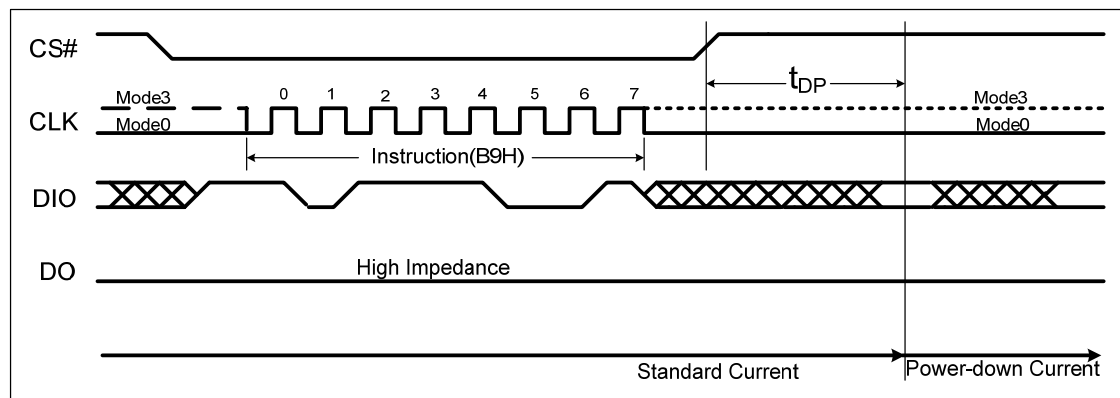

Figure 18, Deep Power-down Instruction Sequence Diagram

Release Power-down / Device ID (ABh)

The Release from Power-down / Device ID instruction is a multi-purpose instruction. It can be used to release the device from the power-down state, obtain the device's electronic identification (ID) number or do both.

When used only to release the device from the power-down state, the instruction is issued by driving the CS# pin low, shifting the instruction code “ABh” and driving CS# high as shown in figure 19. After the time duration of t_{RES1} (See AC Characteristics) the device will resume normal operation and other instructions will be accepted. The CS# pin must remain high during the t_{RES1} time duration.

When used only to obtain the Device ID while not in the power-down state, the instruction is initiated by driving the CS# pin low and shifting the instruction code “ABh” followed by 3-dummy bytes. The Device ID bits are then shifted out on the falling edge of CLK with most significant bit (MSB) first as

shown in figure 20. The Device ID value for the ZD25D80 is listed in Manufacturer and Device Identification table. The Device ID can be read continuously. The instruction is completed by driving CS# high.

When used to release the device from the power-down state and obtain the Device ID, the instruction is the same as previously described, and shown in figure 20, except that after CS# is driven high it must remain high for a time duration of t_{RES2} (See AC Characteristics). After this time duration the device will resume normal operation and other instructions will be accepted. If the Release from Power-down / Device ID instruction is issued while an Erase, Program or Write cycle is in process (when BUSY equals 1) the instruction is ignored and will not have any effects on the current cycle.

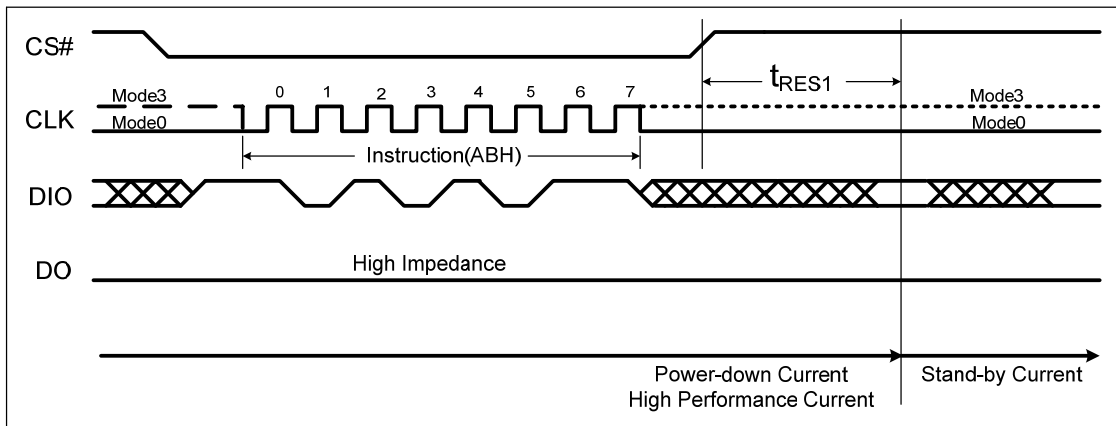

Figure 19, Release Power-down Instruction Sequence

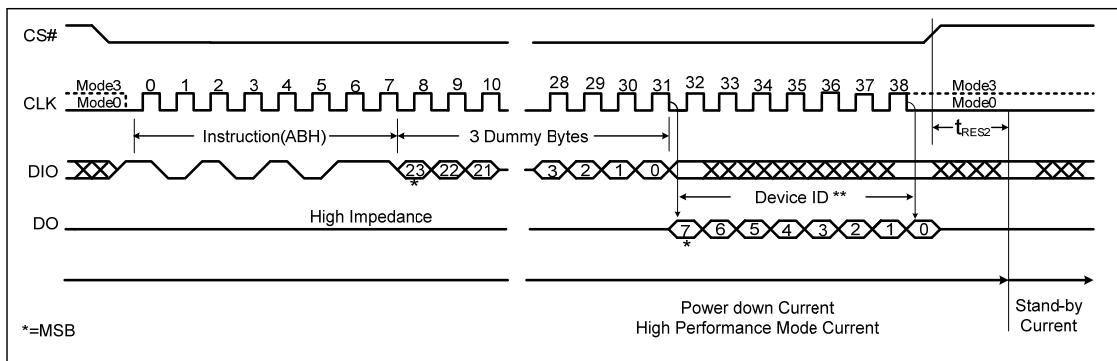

Figure 20, Release Power-down / Device ID Instruction Sequence Diagram

Read Manufacturer / Device ID (90h)

The Read Manufacturer/Device ID instruction is an alternative to the Release from Power-down /Device ID instruction that provides both the JEDEC assigned manufacturer ID and the specific device ID.

The Read Manufacturer/Device ID instruction is very similar to the Release from Power-down / Device ID instruction. The instruction is initiated by driving the CS# pin low and shifting the instruction code “90h” followed by a 24-bit address (A23-A0) of 000000h. After which, the Manufacturer ID for Zetta Device (XXh) and the Device ID are shifted out on the falling edge of CLK with most significant bit (MSB) first as shown in Figure 21. The Device ID values for the ZD25D80 are listed in Table 5. If the 24-bit address is initially set to 000001h the Device ID will be read first.

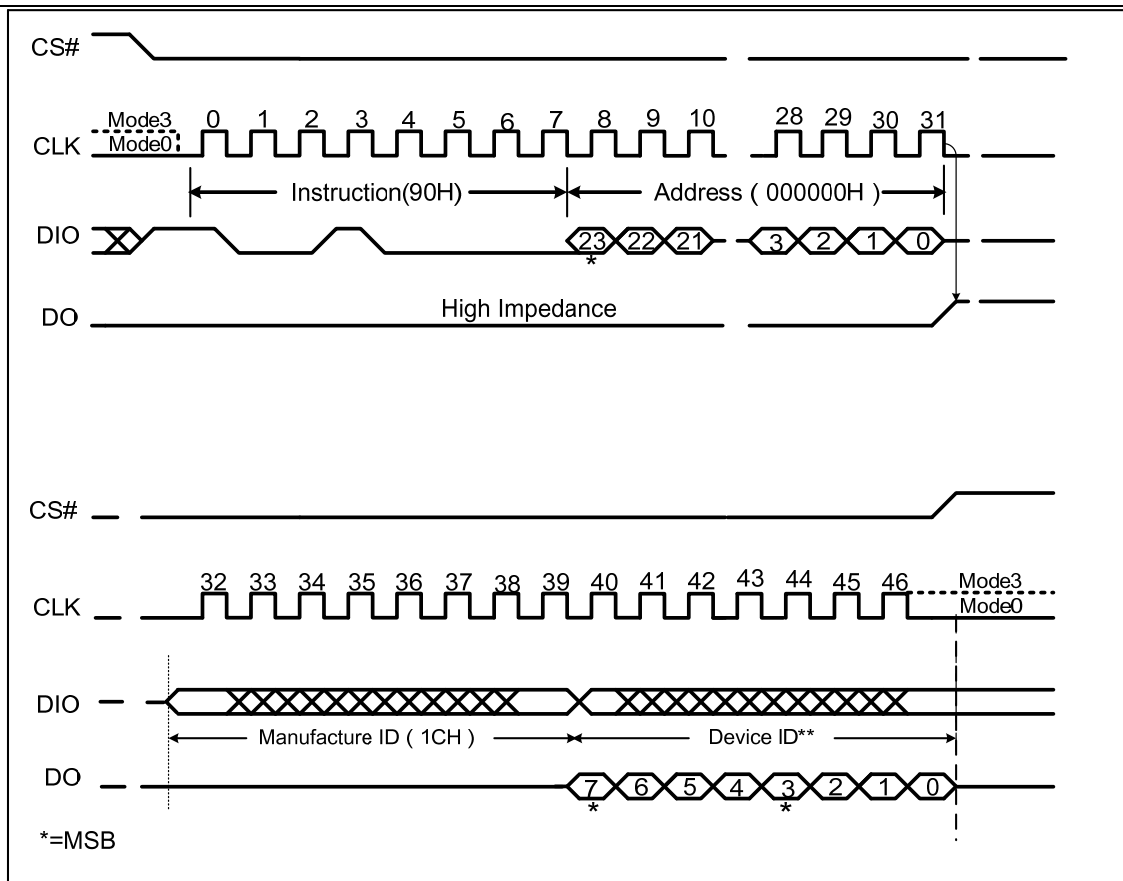

Figure 21, Read Manufacturer / Device ID Diagram

Read Identification (RDID) (9Fh)

For compatibility reasons, the ZD25D80 provides several instructions to electronically determine the identity of the device. The Read JEDEC ID instruction is compatible with the JEDEC standard for SPI compatible serial memories that was adopted in 2003.

The instruction is initiated by driving the CS# pin low and shifting the instruction code “9Fh”. The JEDEC assigned Manufacturer ID byte for Zetta Device (XXh) and two Device ID bytes, Memory Type (ID15-ID8) and Capacity (ID7-ID0) are then shifted out on the falling edge of CLK with most significant bit (MSB) first as shown in figure 22. For memory type and capacity values refer to Manufacturer and Device Identification table.

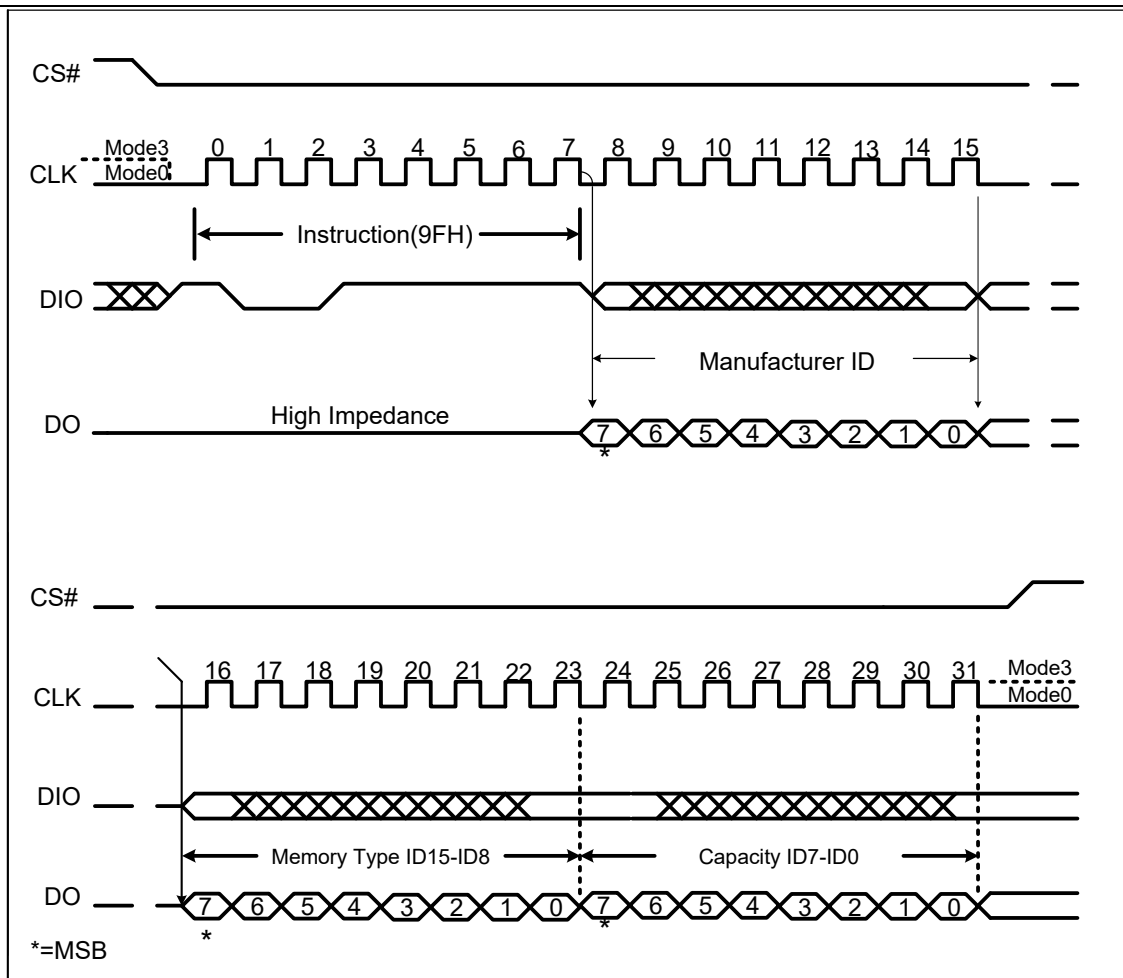

Figure 22, Read JEDEC ID instruction Sequence Diagram

8 ELECTRICAL CHARACTERISTICS

Power-up Timing

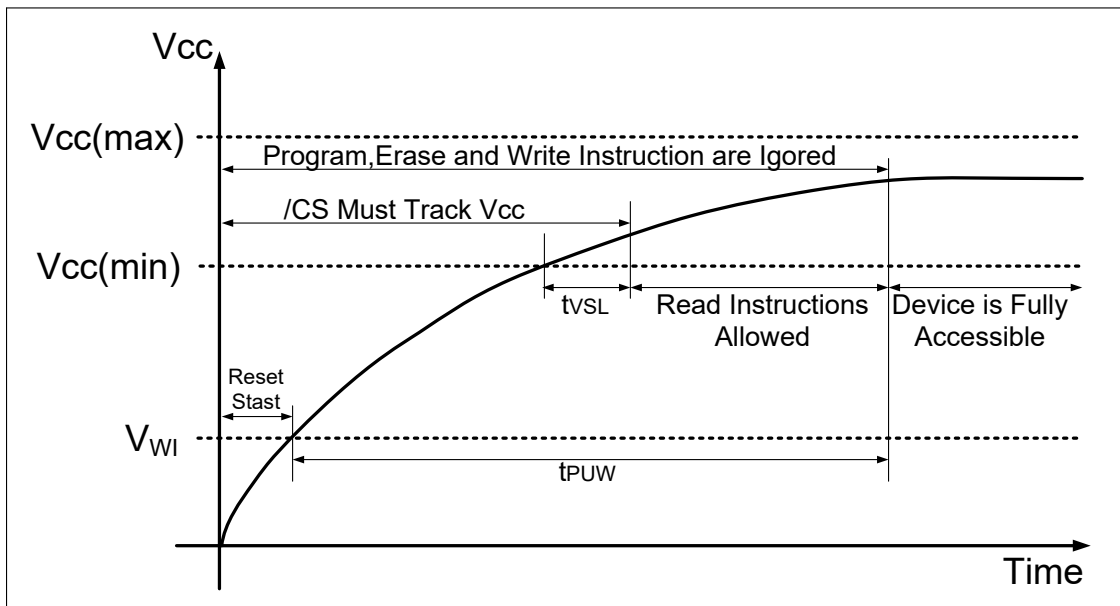

Figure 23, Power-up Timing

Table 6, Power-up Timing

PARAMETER	SYMBOL	TYPE		UNIT
		MIN	MAX	
Vcc(min) to CS# Low	tVSL ⁽¹⁾	10		μs
Time Delay Before Write Instruction	tPUW ⁽¹⁾	1	10	ms
Write Inhibit Threshold Voltage	V _{WI} ⁽¹⁾	1	2	V

Note:

1. The parameters are characterized only.
2. VCC (max.) is 3.6V and VCC (min.) is 2.7V

Absolute Maximum Ratings

Stresses above the values so mentioned above may cause permanent damage to the device. These values are for a stress rating only and do not imply that the device should be operated at conditions up to or above these values.

Table 7, Absolute Maximum Ratings

PARAMETERS	SYMBOL	CONDITIONS	RANGE	UNIT
Supply Voltage	VCC		-0.6 to +4.0	V
Voltage applied on any pin	V _{IO}	Relative to Ground	-0.6 to VCC+0.4	V
Transient Voltage on any Pin	V _{IOT}	<20ns Transient Relative to Ground	-2.0 to VCC+2.0	V
Storage Temperature	T _{STG}		-65 to +150	°C
Lead Temperature	T _{LEAD}		See Note ⁽³⁾	°C
Electrostatic Discharge Voltage	V _{ESD}	Human Body Model ⁽⁴⁾	-2000 to +2000	V

Notes:

1. Specification for ZD25D80 is preliminary. See preliminary designation at the end of this document.
2. This device has been designed and tested for the specified operation ranges. Proper operation outside of these levels is not guaranteed. Exposure to absolute maximum ratings may affect device reliability. Exposure beyond absolute maximum ratings may cause permanent damage.
3. Compliant with JEDEC Standard J-STD-20C for small body Sn-Pb or Pb-free (Green) assembly and the European directive on restrictions on hazardous substances (RoHS) 2002/95/EU.
4. JEDEC Std JESD22-A114A (C1=100 pF, R1=1500 ohms, R2=500 ohms).

Recommended Operating Ranges

Table 8, Recommended Operating Ranges

PARAMETER	SYMBOL	CONDITIONS	SPEC		UNIT
			MIN	MAX	
Supply Voltage	VCC	FR=104MHz, fR=50MHz	2.7	3.6	V
Ambient Temperature, Operating	TA	Industrial	-40	+85	°C

Notes: 1. Recommended Operating Ranges define those limits between which the functionality of the device is guaranteed.

DC Characteristics

Table 9. DC Characteristics

SYMBOL	PARAMETER	CONDITIONS	SPEC			UNIT
			MIN	TYP	MAX	
CIN(1)	Input Capacitance	VIN = 0V(2)			6	pF
Cout(1)	Output Capacitance	VOUT = 0V(2)			8	pF
ILI	Input Leakage				±2	μA
ILO	I/O Leakage				±2	μA
ICC1	Standby Current	CS# = VCC, VIN = GND or VCC		1	5	μA
ICC2	Power-down Current	CS# = VCC, VIN = GND or VCC		1	5	μA
ICC3	Current Read Data / Dual Output Read 33MHz(2)	C = 0.1 VCC / 0.9 VCC DO = Open		6/7	9/10	mA
ICC3	Current Read Data / Dual Output Read 85MHz(2)	C = 0.1 VCC / 0.9 VCC DO = Open		9/10	13/15	mA
ICC4	Current Page Program	CS# = VCC			10	mA
ICC5	Current Write Status Register	CS# = VCC			10	mA
ICC6	Current Sector/Block Erase	CS# = VCC			10	mA
ICC7	Current Chip Erase	CS# = VCC			10	mA
VIL	Input Low Voltage		-0.5		VCC x 0.2	V
VIH	Input High Voltage		VCC x 0.7		VCC + 0.4	V
VOL	Output Low Voltage	IOL = 1.6 mA	VSS		0.4	V
VOH	Output High Voltage	IOH = -100 μA	VCC - 0.2		VCC	V

Notes:

1. Tested on sample basis and specified through design and characterization data. TA=25° C, VCC 3V.
2. Checker Board Pattern.

AC Measurement Conditions

Table 10, AC Measurement Conditions

Symbol	PARAMETER	Min.	Max.	Unit
CL	Load Capacitance		30	pF
TR, TF	Input Rise and Fall Times		5	ns
VIN	Input Pulse Voltages	0.2VCC to 0.8VCC		V
VtIN	Input Timing Reference Voltages	0.3VCC to 0.7VCC		V
VtON	Output Timing Reference Voltages	0.5 VCC to 0.5 VCC		V

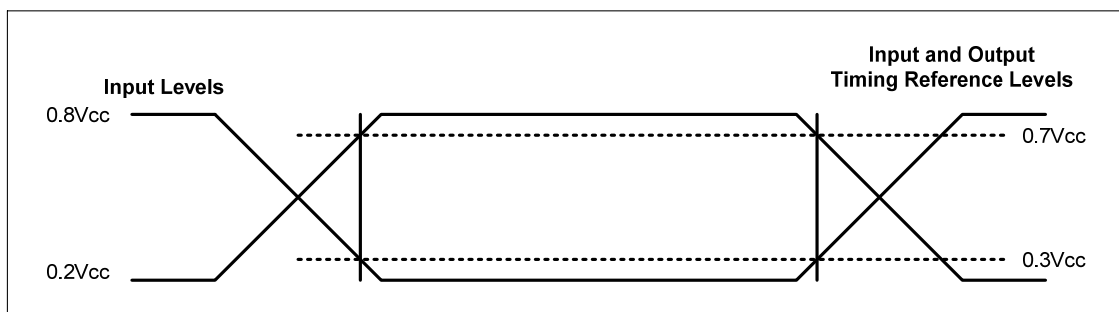

Figure 24, AC Measurement I/O Waveform

AC Electrical Characteristics

Table 11, AC Electrical Characteristics

SYMBOL	ALT	Parameter	SPEC			UNIT
			MIN	TYP	MAX	
FR	fC	Clock frequency For all instructions, except Read Data (03h) and Dual output(3bh) 2.7V-3.6V VCC & Industrial Temperature	D.C.		85	MHz
		Clock frequency For dual output(3bh) 2.7V-3.6V VCC & Industrial Temperature			80	
fR		Clock freq. Read Data instruction (03h)	D.C.		50	MHz
tCLH, tCLL(1)		Clock High, Low Time for all instructions except Read Data (03h)	4			Ns
tCRLH, tCRLL(1)		Clock High, Low Time for Read Data (03h) instruction	4			Ns
tCLCH(2)		Clock Rise Time peak to peak	0.1			V/ns
tCHCL(2)		Clock Fall Time peak to peak	0.1			V/ns
tSLCH	tCSS	CS# Active Setup Time relative to CLK	5			Ns
tCHSL		CS# Not Active Hold Time relative to CLK	5			Ns
tDVCH	tDSU	Data In Setup Time	2			Ns
tCHDX	tDH	Data In Hold Time	5			Ns
tCHSH		CS# Active Hold Time relative to CLK	5			Ns
tSHCH		CS# Not Active Setup Time relative to CLK	5			Ns
tSHSL	tCSH	CS# Deselect Time (for Array Read → Array Read / Erase or Program → Read Status Register)	40/130			Ns
tSHQZ(2)	tDIS	Output Disable Time			7	Ns
tCLQV	tV	Clock Low to Output Valid 2.7V-3.6V / 3.0V-3.6V			7	Ns
tCLQX	tHO	Output Hold Time	2			Ns
tHLCH		/HOLD Active Setup Time relative to CLK	5			Ns
tCHHH		/HOLD Active Hold Time relative to CLK	5			Ns
tHHCH		/HOLD Not Active Setup Time relative to CLK	5			Ns
tCHHL		/HOLD Not Active Hold Time relative to CLK	5			Ns
tHHQX(2)	tLZ	/HOLD to Output Low-Z			7	Ns
tHLQZ(2)	tHZ	/HOLD to Output High-Z			12	Ns
tWHSL(3)		Write Protect Setup Time Before CS# Low	20			Ns
tSHWL(3)		Write Protect Hold Time After CS# High	100			Ns
tDP(2)		CS# High to Power-down Mode			3	Us
tRES1(2)		CS# High to Standby Mode without Electronic Signature Read			3	Us
tRES2(2)		CS# High to Standby Mode with Electronic Signature Read			1.8	Us
tW		Write Status Register Time		2	15	Ms
tPP		Page Program Time		0.9	4	Ms
tSE		Sector Erase Time (4KB)		50	300	Ms
tBE		Block Erase Time (64KB)		0.3	1	S
tCE		Chip Erase Time		5	15	S

Notes:

- 1, Clock high + Clock low must be less than or equal to 1/fC.
- 2, Value guaranteed by design and/or characterization, not 100% tested in production.
- 3, Only applicable as a constraint for a Write Status Register instruction when Sector Protect Bit is set to 1.
- 4, For multiple bytes after first byte within a page, tBPN = tBP1 + tBP2 * N (typical) and tBPN = tBP1 + tBP2 * N (max), where N = number of bytes programmed.

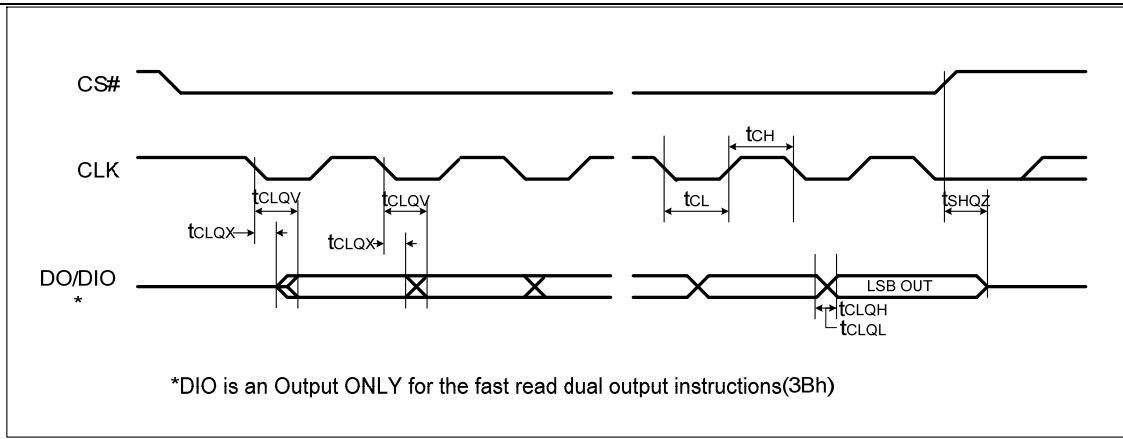

Figure 25, Serial Output Timing

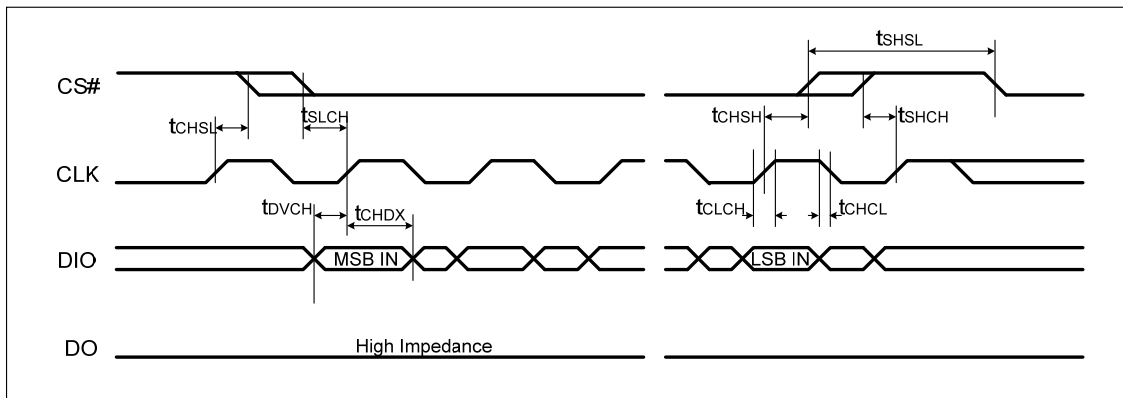

Figure 26, Input Timing

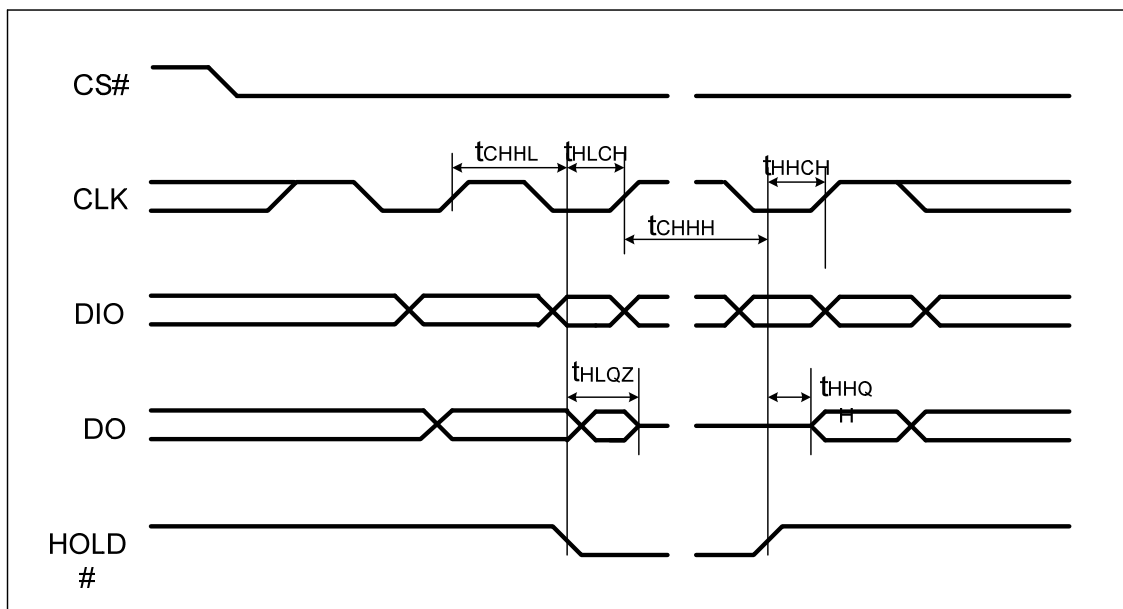
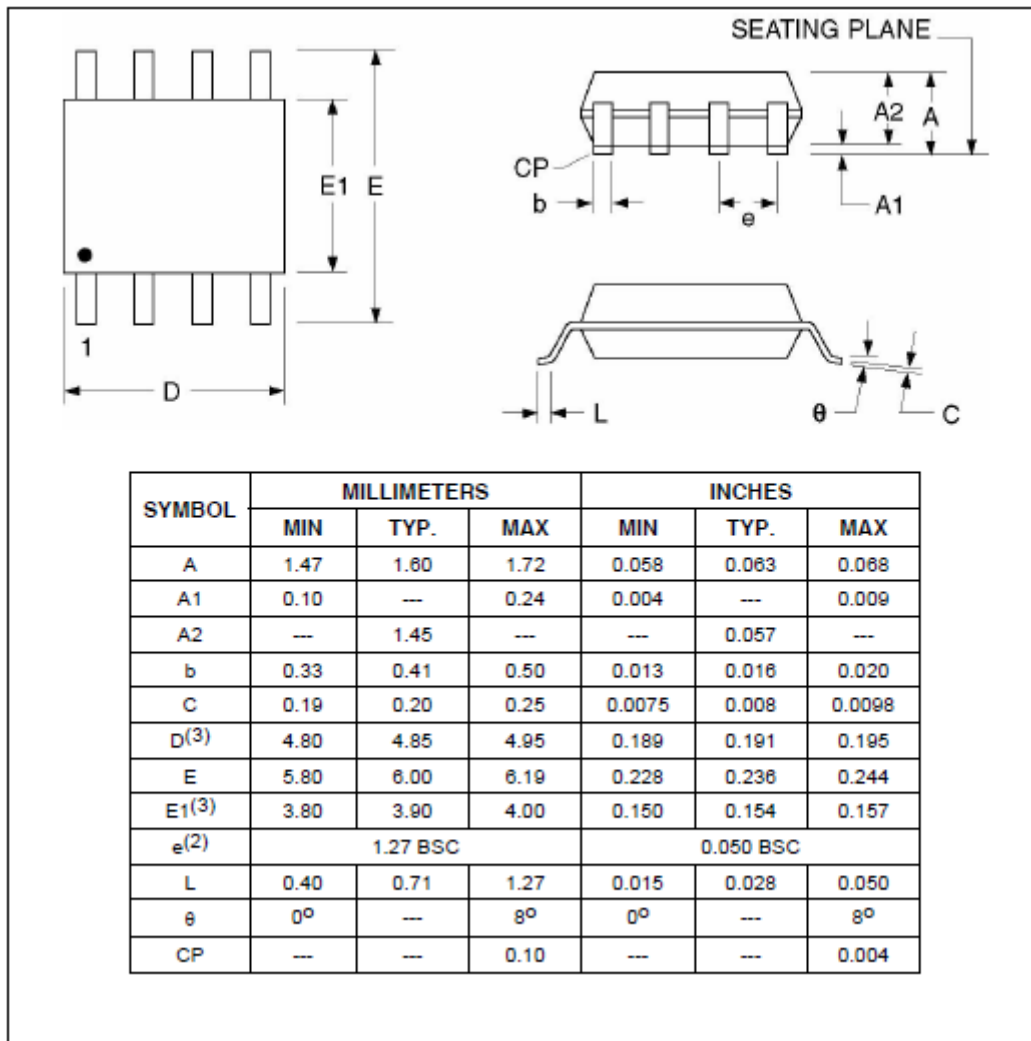

Figure 27, Hold Timing

9 PACKAGE MECHANICAL

8-Pin SOIC 150-mil



8-Pin SOIC 208-mil

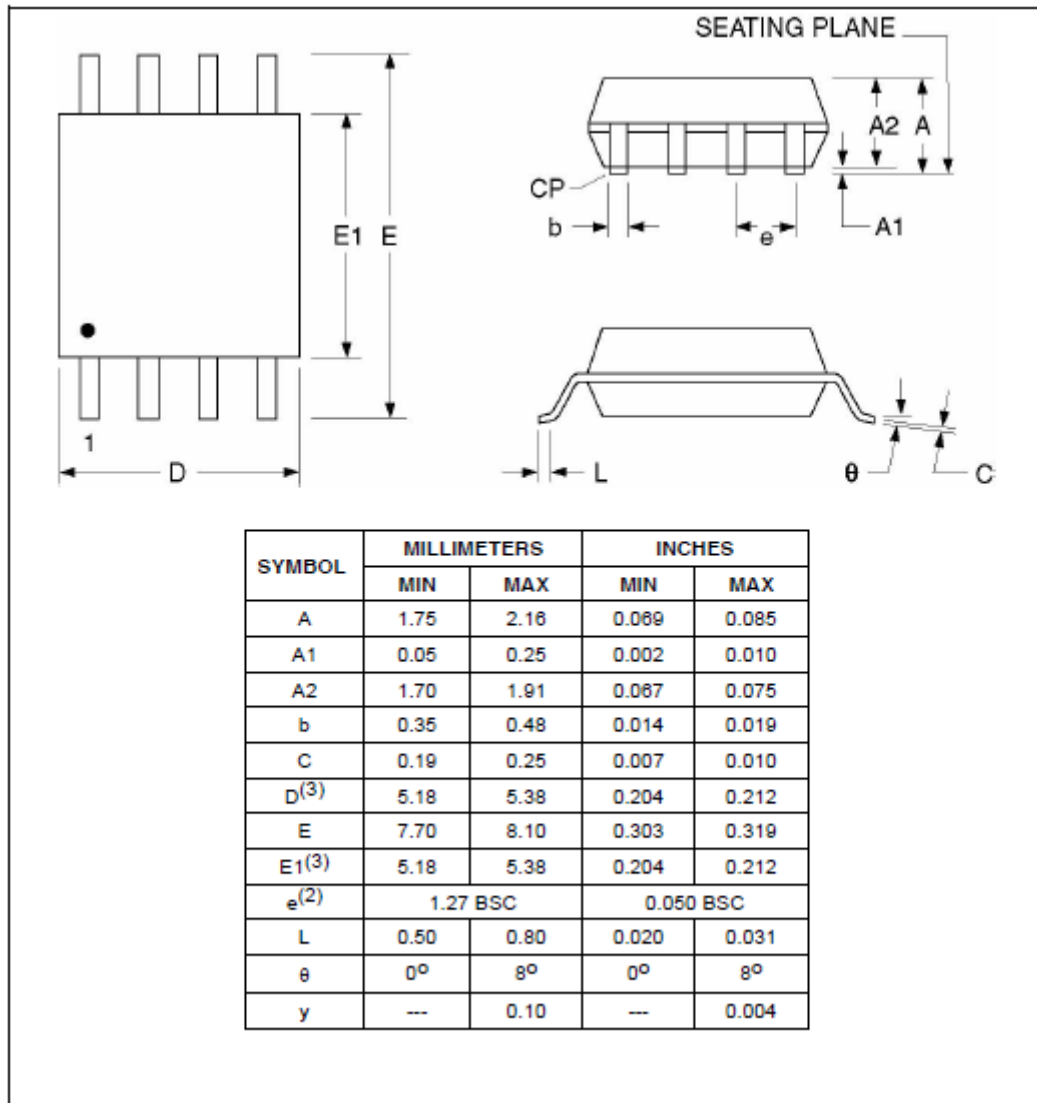

WSO8 8 (6x5mm)

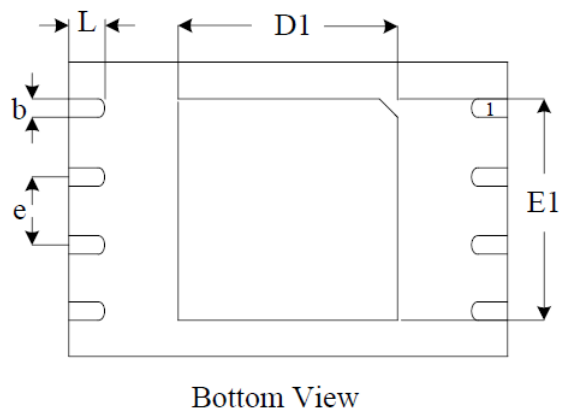
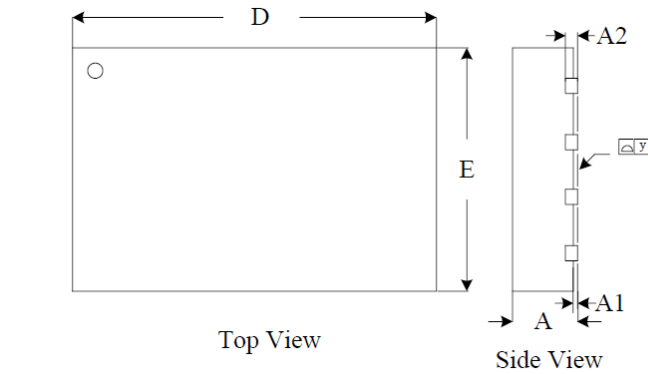

Dimensions

Symbol		A	A1	A2	b	D	D1	E	E1	e	y	L
Unit												
mm	Min	0.70		0.19	0.35	5.90	3.25	4.90	3.85		0.00	0.50
	Nom	0.75		0.22	0.42	6.00	3.37	5.00	3.97	1.27BSC	0.04	0.60
	Max	0.80	0.05	0.25	0.48	6.10	3.50	5.10	4.10		0.08	0.75
Inch	Min	0.028		0.007	0.014	0.232	0.128	0.193	0.151		0.000	0.020
	Nom	0.030		0.009	0.016	0.236	0.133	0.197	0.156	0.05BSC	0.001	0.024
	Max	0.032	0.002	0.010	0.019	0.240	0.138	0.201	0.161		0.003	0.030

Note:

- Both package length and width do not include mold flash.
- The exposed metal pad area on the bottom of the package is connected to device ground (GND pin), so both Floating and connecting GND of exposed pad are also available.

USON8 (3*2mm)

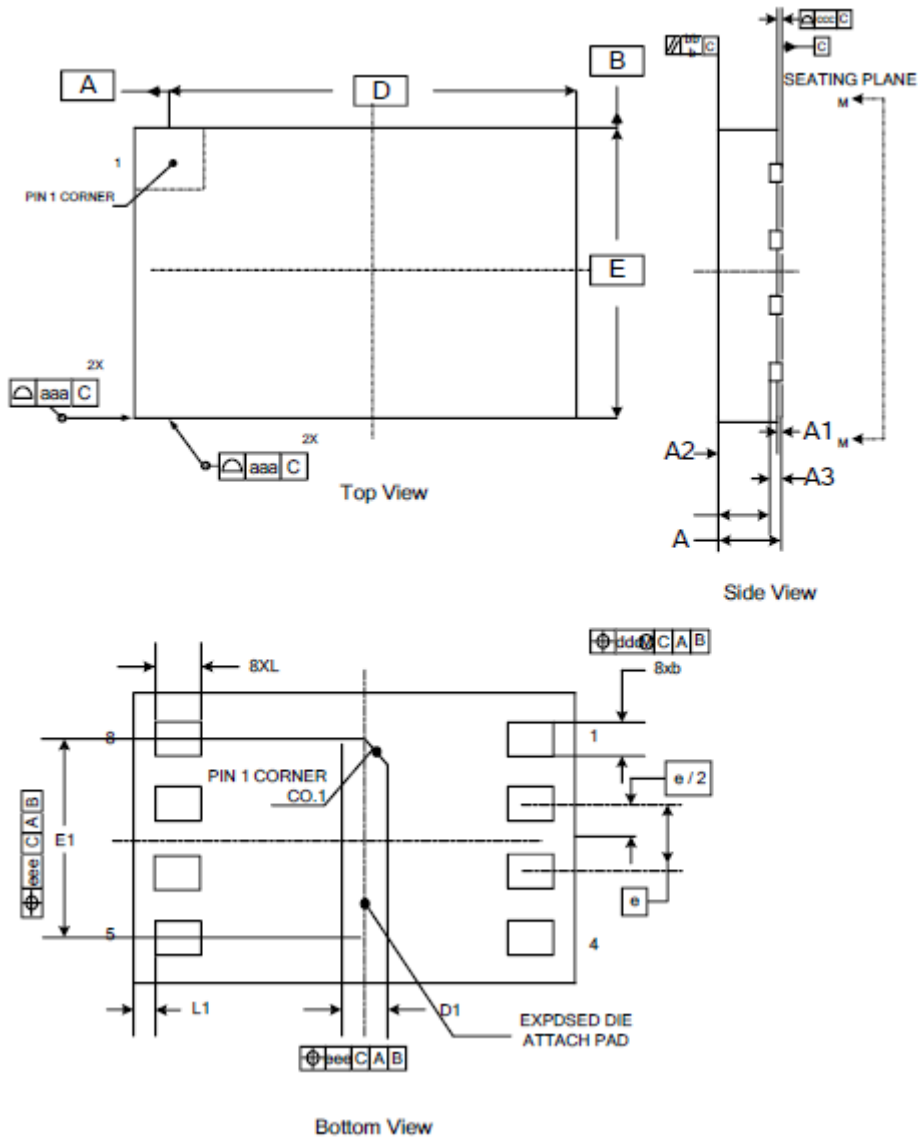

Dimensions

Symbol		A	A1	A2	A3	b	D	E	e	J	K	L
Unit												
mm	Min	0.40	0.00	0.25	0.150 REF	0.20	2.90	1.90	0.5 BSC	0.15	1.55	0.30
	Nom	0.45	---	0.30		0.25	3.00	2.00		0.20	1.60	0.35
	Max	0.50	0.05	0.35		0.30	3.10	2.10		0.25	1.65	0.40
Inch	Min	0.015	0.00	0.009	0.005 REF	0.007	0.114	0.074	0.019 BSC	0.005	0.061	0.011
	Nom	0.018	---	0.012		0.010	0.118	0.079		0.008	0.063	0.014
	Max	0.019	0.001	0.013		0.012	0.122	0.082		0.009	0.064	0.015

USON8 (3*3mm, 0.65mm)

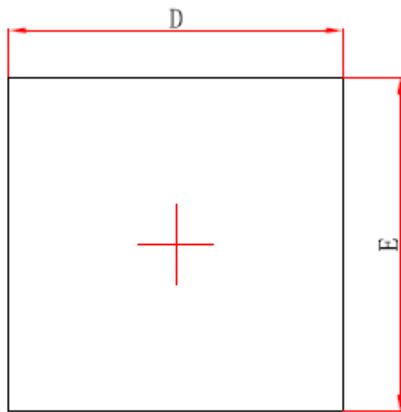

Top View

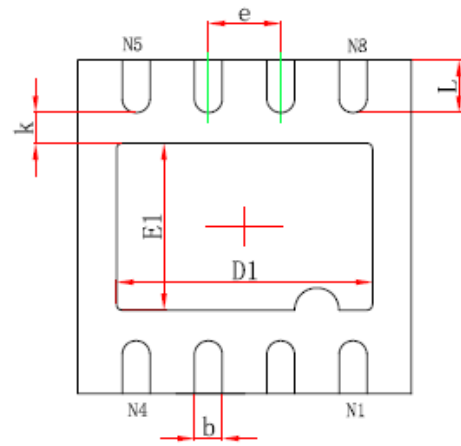

Bottom View

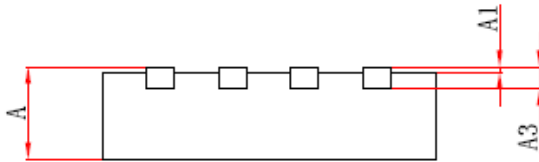

Side View

Symbol	Dimensions In Millimeters		Dimensions In Inches	
	Min.	Max.	Min.	Max.
A	0.700/0.800	0.800/0.900	0.028/0.031	0.031/0.035
A1	0.000	0.050	0.000	0.002
A3	0.203REF.		0.008REF.	
D	2.924	3.076	0.115	0.121
E	2.924	3.076	0.115	0.121
D1	2.200	2.400	0.087	0.094
E1	1.400	1.600	0.055	0.063
k	0.200MIN.		0.008MIN.	
b	0.200	0.300	0.008	0.012
e	0.650TYP.		0.026TYP.	
L	0.399	0.551	0.016	0.022

USON8 (3*3mm, 0.5mm)

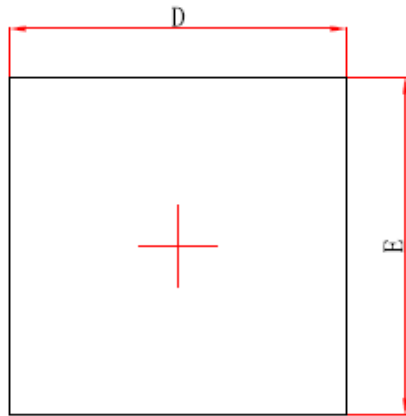

Top View

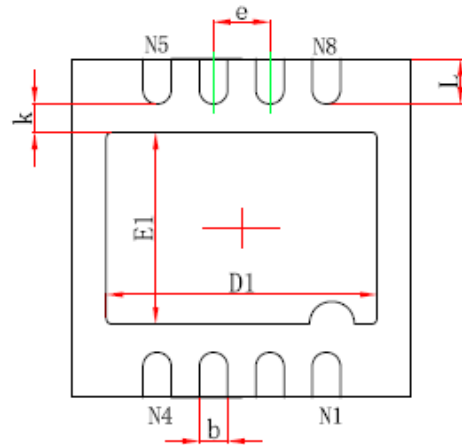

Bottom View

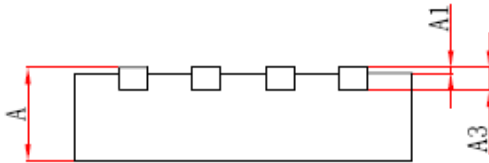

Side View

Symbol	Dimensions In Millimeters		Dimensions In Inches	
	Min.	Max.	Min.	Max.
A	0.700/0.800	0.800/0.900	0.028/0.031	0.031/0.035
A1	0.000	0.050	0.000	0.002
A3	0.203REF.		0.008REF.	
D	2.924	3.076	0.115	0.121
E	2.924	3.076	0.115	0.121
D1	2.300	2.500	0.091	0.098
E1	1.600	1.800	0.063	0.071
k	0.200MIN.		0.008MIN.	
b	0.200	0.300	0.008	0.012
e	0.500TYP.		0.020TYP.	
L	0.324	0.476	0.013	0.019

8-Pin TSSOP8 173-mil

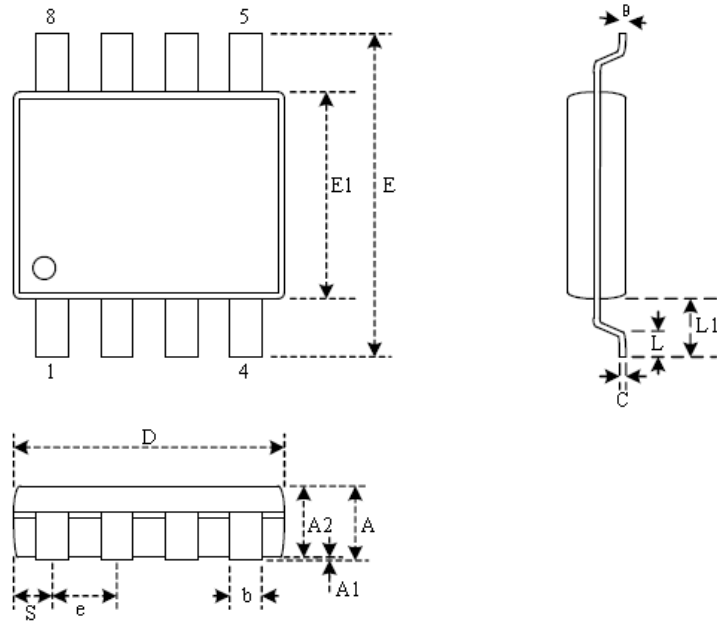

Dimensions

Symbol		A	A1	A2	b	C	D	E	E1	e	L	L1	θ
Unit													
mm	Min	-	0.05	0.80	0.19	0.09	2.83	6.20	4.30	-	0.45	0.85	0
	Nom	-	0.10	0.92	0.24	0.14	2.96	6.40	4.40	0.65	0.60	1.00	4
	Max	1.20	0.15	1.05	0.30	0.20	3.10	6.60	4.50	-	0.75	1.15	8
Inch	Min	-	0.002	0.031	0.007	0.003	0.111	0.244	0.169	-	0.018	0.033	0
	Nom	-	0.004	0.036	0.010	0.006	0.116	0.252	0.173	0.026	0.024	0.039	4
	Max	0.047	0.006	0.041	0.012	0.008	0.122	0.260	0.177	-	0.030	0.045	8

Note: Both package length and width do not include mold flash.

REVISION LIST

Version No.	Description	Date
A0	Initial Release	2014-01-26
A1	Add USON8(3*2mm) and USON8(3*3mm, 0.65mm) package	2015-09-24
A2	Add USON8(3*3mm, 0.5mm) package	2015-10-12
A3	Add WSON8(6*5mm) package	2016-04-21