

MT1389EE-L1 (DVDM ASSY : IC201)

• DVD IC

● Pin Arrangement

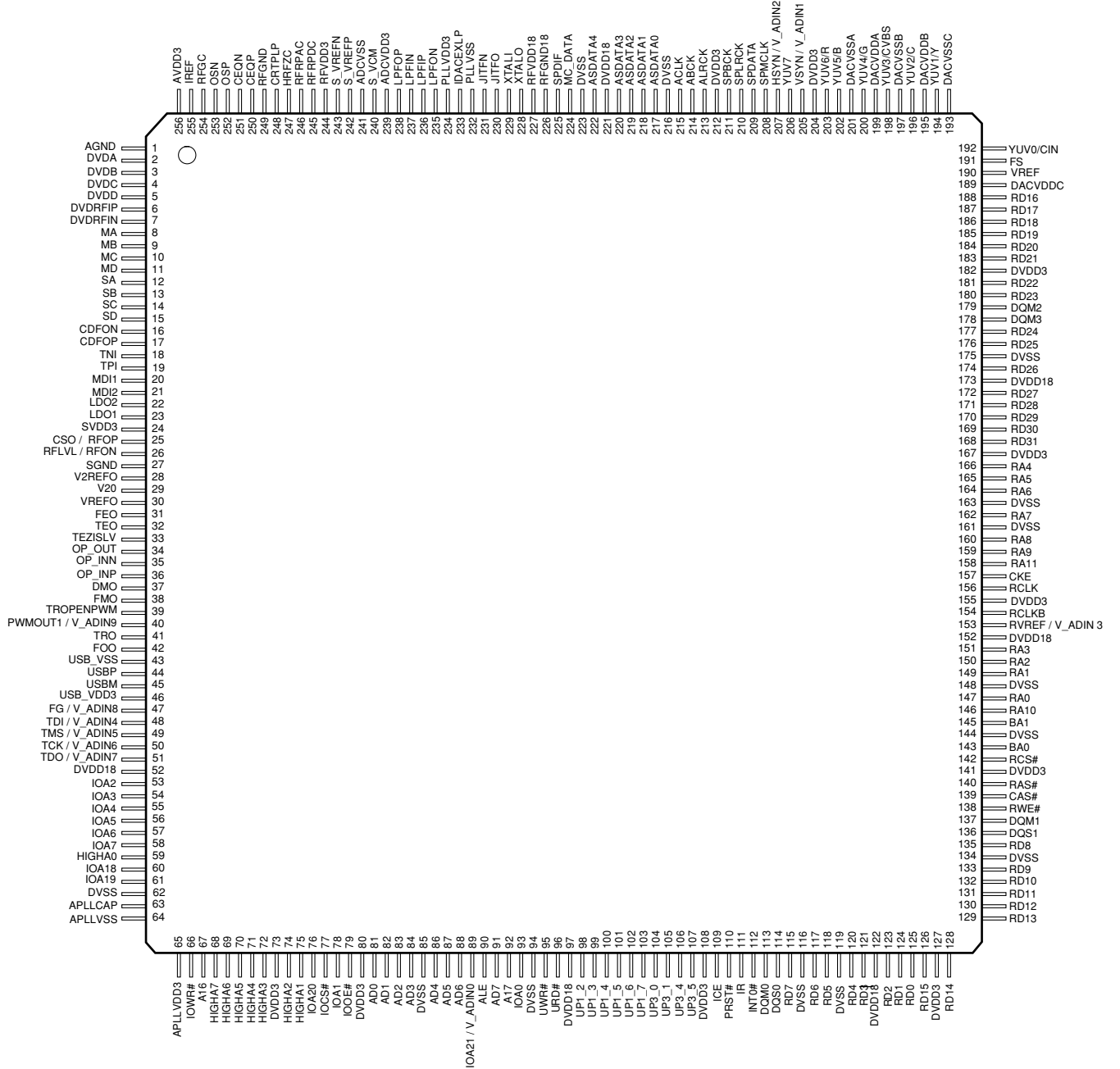

● Block Diagram

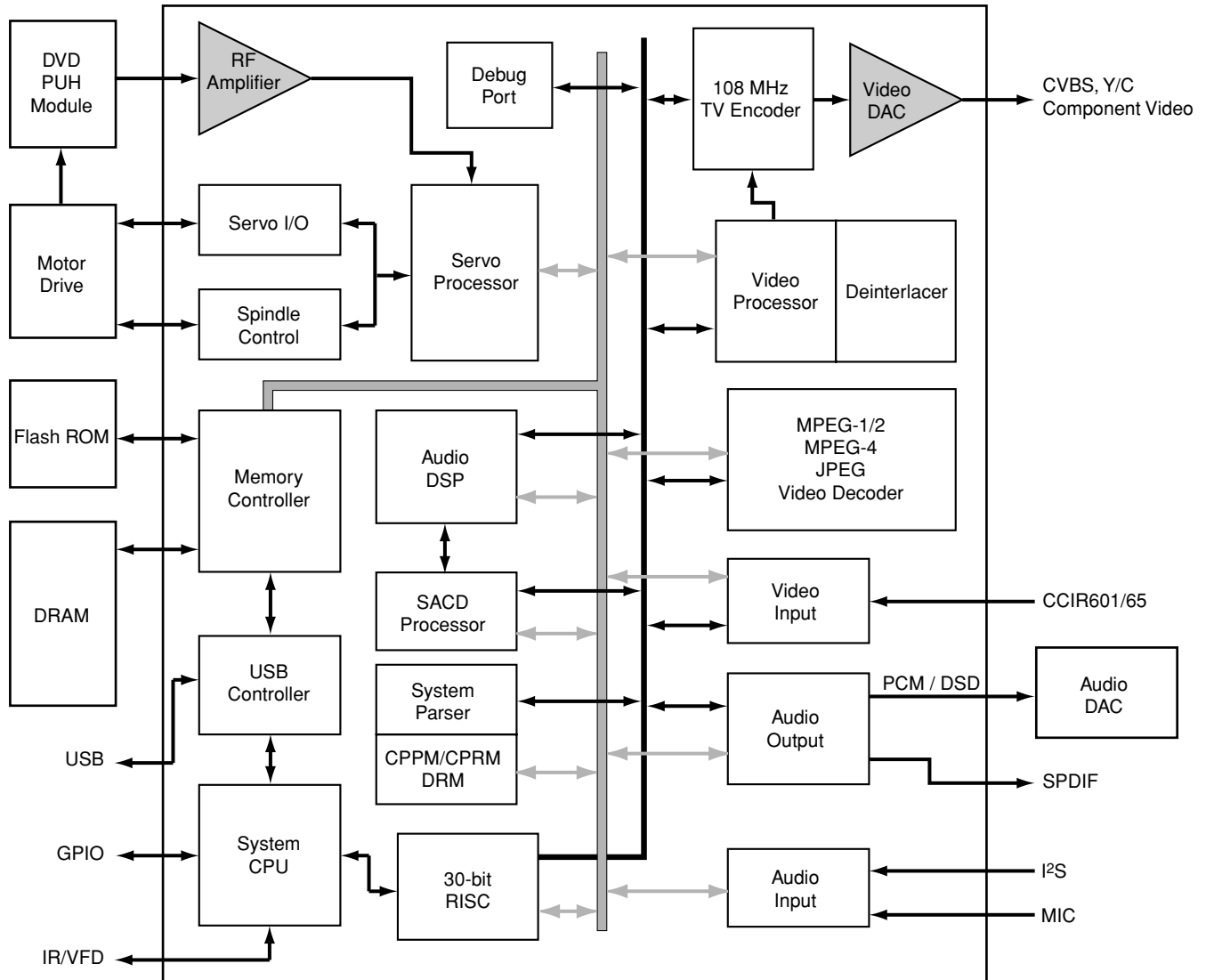

● Pin Function

■ RF Interface (28)

No.	Name	Alt.	I/O	Function
226	RFGND18		Ground	Analog ground
227	RFVDD18		Power	Analog power 1.8V
250	CEQP		Analog output	EQ offset loop capacitance
251	CEQN		Analog output	EQ offset loop capacitance
252	OSP		Analog output	RF Offset cancellation capacitor connecting
253	OSN		Analog output	RF Offset cancellation capacitor connecting
254	RFGC		Analog output	RF AGC loop capacitor connecting for DVD-ROM
255	IREF		Analog Input	Current reference input. It generates reference current for RF path. Connect an external 15K resistor to this pin and AVSS.
256	AVDD3		Power	Analog power 3.3V
1	AGND		Ground	Analog ground
2	DVDA		Analog Input	AC coupled input path A
3	DVDB		Analog Input	AC coupled input path B
4	DVDC		Analog Input	AC coupled input path C
5	DVDD		Analog Input	AC coupled input path D
6	DVDRFIP		Analog Input	AC coupled DVD RF signal input RFIP
7	DVDRFIN		Analog Input	AC coupled DVD RF signal input RFIN
8	MA		Analog Input	DC coupled main-beam RF signal input A
9	MB		Analog Input	DC coupled main-beam RF signal input B
10	MC		Analog Input	DC coupled main-beam RF signal input C
11	MD		Analog Input	DC coupled main-beam RF signal input D
12	SA		Analog Input	DC coupled sub-beam RF signal input A
13	SB		Analog Input	DC coupled sub-beam RF signal input B
14	SC		Analog Input	DC coupled sub-beam RF signal input C
15	SD		Analog Input	DC coupled sub-beam RF signal input D
16	CDFON		Analog Input	CD focusing error negative input
17	CDFOP		Analog Input	CD focusing error positive input
18	TNI		Analog Input	3 beam satellite PD signal negative input
19	TPI		Analog Input	3 beam satellite PD signal positive input

■ ALPC (4)

No.	Name	Alt.	I/O	Function
20	MDI1		Analog Input	Laser power monitor input
21	MDI2		Analog Input	Laser power monitor input
22	LDO2		Analog Output	Laser driver output
23	LDO1		Analog Output	Laser driver output

■ ADC for SACD (5)

No.	Name	Alt.	I/O	Function
239	ADCVDD3		Power	Analog 3.3V Power for ADC
240	S_VCM		Analog Inout	SACD- Common mode reference
241	ADCVSS		Ground	Analog ground for ADC
242	S_VREFP		Analog Inout	SACD- TOP Reference
243	S_VREFN		Analog Inout	SACD- Bottom Reference

■ Reference Voltage (3)

No.	Name	Alt.	I/O	Function
28	V2REFO		Analog output	Reference voltage 2.8V
29	V20		Analog output	Reference voltage 2.0V
30	VREFO		Analog output	Reference voltage 1.4V

■ Analog Monitor Output (7)

No.	Name	Alt.	I/O	Function
24	SVDD3		Power	Analog power 3.3V
25	CSO	RFOP	Analog output	Central servo Positive main beam summing output
26	RFLVL	RFON	Analog output	RFRP low pass, or Negative main beam summing output
27	SGND		Ground	Analog ground
31	FEO		Analog output	Focus error monitor output
32	TEO		Analog output	Tracking error monitor output
33	TEZISLV		Analog output	TE Slicing Level

■ Analog Servo Interface (6)

No.	Name	Alt.	I/O	Function
244	RFVDD3		Power	Analog Power
245	RFRPDC		Analog output	RF ripple detect output
246	RFRPAC		Analog Input	RF ripple detect input(through AC-coupling)
247	HRFZC		Analog Input	High frequency RF ripple zero crossing
248	CRTPLP		Analog output	Defect level filter capacitor connecting
249	RFGND		Ground	Analog Ground

■ RF Data PLL Interface (9)

No.	Name	Alt.	I/O	Function
230	JITFO		Analog output	The output terminal of RF jitter meter.
231	JITFN		Analog Input	The input terminal of RF jitter meter.
232	PLLVSS		Ground	Ground pin for data PLL and related analog circuitry.
233	IDACEXP		Analog output	Data PLL DAC Low-pass filter
234	PLLVDD3		Power	Power pin for data PLL and related analog circuitry.
235	LPFON		Analog Output	The negative output of loop filter amplifier
236	LPFIP		Analog Input	The positive input terminal of loop filter amplifier.
237	LPFIN		Analog Input	The negative input terminal of loop filter amplifier.
238	LPFOP		Analog Output	The positive output of loop filter amplifier

■ Motor and Actuator Driver Interface (10)

No.	Name	Alt.	I/O	Function
34	OP_OUT		Analog output	Op amp output.
35	OP_INN		Analog input	Op amp negative input
36	OP_INP		Analog input	Op amp positive input
37	DMO		Analog Output	Disk motor control output. PWM output.
38	FMO		Analog Output	Feed motor control. PWM output.
39	TROPENPWM		Analog Output	Tray PWM output / Tray open output.
40	PWMOUT1	V_ADIN9	Analog Output	1st General PWM output, or Version AD input 9
41	TRO		Analog Output	Tracking servo output. PDM output of tracking servo compensator.
42	FOO		Analog Output	Focus servo output. PDM output of focus servo compensator
47	FG (Digital pin)	V_ADIN8	LVTTTL 3.3V Input, Schmitt Input, pull-up , with analog input path for V_ADIN8	Motor Hall sensor input, or Version AD input 8

■ General Power / Ground (32)

No.	Name	Alt.	I/O	Function
52, 97, 122, 152, 173, 221	DVDD18		Power	1.8V power pin for internal digital circuitry
85, 116, 144, 163, 216	DVSS		Ground	1.8V Ground pin for internal digital circuitry
73, 80, 108, 127, 141, 155, 167, 182, 212	DVDD3		Power	3.3V power pin for internal digital circuitry
62, 94, 119, 134, 148, 161, 175, 223	DVSS		Ground	3.3V Ground pin for internal digital circuitry
204	DVDD3		Power	3.3V power pin Video DAC digital circuitry only
63	APLLCAP		Analog Inout	APLL External Capacitance connection
64	APLLVSS		Ground	Ground pin for audio clock circuitry
65	APLLVDD3		Power	3.3V Power pin for audio clock circuitry

■ Micro Controller and Flash Interface (48)

No.	Name	Alt.	I/O	Function
59	HIGHA0		Inout, 2-16MA, SR, PU	Microcontroller address 8
75	HIGHA1		Inout, 2-16MA, SR, PU	Microcontroller address 9
74	HIGHA2		Inout, 2-16MA, SR, PU	Microcontroller address 10
72	HIGHA3		Inout, 2-16MA, SR, PU	Microcontroller address 11
71	HIGHA4		Inout, 2-16MA, SR, PU	Microcontroller address 12
70	HIGHA5		Inout, 2-16MA, SR, PU	Microcontroller address 13
69	HIGHA6		Inout, 2-16MA, SR, PU	Microcontroller address 14
68	HIGHA7		Inout, 2-16MA, SR, PU	Microcontroller address 15
91	AD7		Inout, 2-16MA, SR	Microcontroller address/data 7
88	AD6		Inout, 2-16MA, SR	Microcontroller address/data 6
87	AD5		Inout, 2-16MA, SR	Microcontroller address/data 5
86	AD4		Inout, 2-16MA, SR	Microcontroller address/data 4
84	AD3		Inout, 2-16MA, SR	Microcontroller address/data 3
83	AD2		Inout, 2-16MA, SR	Microcontroller address/data 2
82	AD1		Inout, 2-16MA, SR	Microcontroller address/data 1
81	AD0		Inout, 2-16MA, SR	Microcontroller address/data 0
93	IOA0		Inout, 2-16MA, SR, PU	Microcontroller address 0 / IO
78	IOA1		Inout, 2-16MA, SR, PU	Microcontroller address 1 / IO
53	IOA2		Inout, 2-16MA, SR, PU	Microcontroller address 2 / IO
54	IOA3		Inout, 2-16MA, SR, PU	Microcontroller address 3 / IO
55	IOA4		Inout, 2-16MA, SR, PU	Microcontroller address 4 / IO
56	IOA5		Inout, 2-16MA, SR, PU	Microcontroller address 5 / IO
57	IOA6		Inout, 2-16MA, SR, PU	Microcontroller address 6 / IO
58	IOA7		Inout, 2-16MA, SR, PU	Microcontroller address 7 / IO
67	A16		Output, 2-16MA, SR	Flash address 16
92	A17		Output, 2-16MA, SR	Flash address 17
60	IOA18		Inout, 2-16MA, SR, SMT	Flash address 18 / IO
61	IOA19		Inout, 2-16MA, SR, SMT	Flash address 19 / IO
76	IOA20		Inout, 2-16MA, SR, SMT	Flash address 20 / IO
89	IOA21	V_ADINO	Inout, 2-16MA, SR, SMT	Flash address 21 / IO While External FLASH size <= 2MB: Version AD input port 0, or GPIO

No.	Name	Alt.	I/O	Function
90	ALE		Inout, 2-16MA, SR, PU, SMT	Microcontroller address latch enable
79	IOOE#		Inout, 2-16MA, SR, SMT	Flash output enable, active low / IO
66	IOWR#		Inout, 2-16MA, SR, SMT	Flash write enable, active low / IO
77	IOCS#		Inout, 2-16MA, SR, PU, SMT	Flash chip select, active low / IO
95	UWR#		Inout, 2-16MA, SR, PU, SMT	Microcontroller write strobe, active low
96	URD#		Inout, 2-16MA, SR, PU, SMT	Microcontroller read strobe, active low
98	UP1_2		Inout, 4MA, SR, PU, SMT	Microcontroller port 1-2
99	UP1_3		Inout, 4MA, SR, PU, SMT	Microcontroller port 1-3
100	UP1_4		Inout, 4MA, SR, PU, SMT	Microcontroller port 1-4
101	UP1_5		Inout, 4MA, SR, PU, SMT	Microcontroller port 1-5
102	UP1_6	SCL	Inout, 4MA, SR, PU, SMT	Microcontroller port 1-6 I ² C clock pin
103	UP1_7	SDA	Inout, 4MA, SR, PU, SMT	Microcontroller port 1-7 I ² C data pin
104	UP3_0	RXD	Inout, 4MA, SR, PU, SMT	Microcontroller port 3-0 8032 RS232 RXD
105	UP3_1	TXD	Inout, 4MA, SR, PU, SMT	Microcontroller port 3-1 8032 RS232 TXD
106	UP3_4	RXD SCL	Inout, 4MA, SR, PU, SMT	Microcontroller port 3-4 Hardwired RD232 RXD I ² C clock pin
107	UP3_5	TXD SDA	Inout, 4MA, SR, PU, SMT	Microcontroller port 3-5 Hardwired RD232 TXD I ² C data pin
111	IR		Input, SMT	IR control signal input
112	INT0#		Inout, 2-16MA, SR, PU, SMT	Microcontroller external interrupt 0, active low

■ Audio Interface (14)

No.	Name	Alt.	I/O	Function
208	SPMCLK	SCLK0	Inout	Audio DAC master clock of SPDIF input While SPDIF input is not used: Serial interface port 0 clock pin GPIO
209	SPDATA	SDIN0	Inout	Audio data of SPDIF input While SPDIF input is not used: Serial interface port 0 data-in GPIO
210	SPLRCK	SDO0	Inout	Audio left/right channel clock of SPDIF input While SPDIF input is not used: Serial interface port 0 data-out GPIO
211	SPBCK	SDCS0 ASDATA5	Inout	Audio bit clock of SPDIF input While SPDIF input is not used: Serial interface port 0 chip select Audio serial data 5 part I : DSD data sub-woofer channel or Microphone output GPIO
213	ALRCK		Inout 4MA, PD, SMT	Audio left/right channel clock Trap value in power-on reset: 1 : use external 373 0 : use internal 373
214	ABCK	Fs64	Output 4MA	Audio bit clock Phase de-modulation
215	ACLK		Inout, 4MA	Audio DAC master clock
217	ASDATA0		Inout, 4MA, PD SMT	Audio serial data 0 (Front-Left/Front-Right) DSD data left channel Trap value in power-on reset : 1 : manufactory test mode 0 : normal operation
218	ASDATA1		Inout, 4MA, PD SMT	Audio serial data 1 (Left-Surround/Right-Surround) DSD data right channel Trap value in power-on reset : 1 : manufactory test mode 0 : normal operation While only 2 channels output: GPIO
219	ASDATA2		Inout, 4MA, PD SMT	Audio serial data 2 (Center/LFE) DSD data left surround channel Trap value in power-on reset : 1 : manufactory test mode 0 : normal operation While only 2 channels output: GPIO
220	ASDATA3		Inout, 4MA, PD SMT	Audio serial data 3 (Center-back/ Center-left-back/Center-right-back, in 6.1 or 7.1 mode) DSD data right surround channel Trap value in power-on reset : 1 : manufactory test mode 0 : normal operation While only 2 channels output: GPIO
222	ASDATA4	INT1#	Inout, 4MA, PD SMT	Audio serial data 4 (Down-mixed Left/Right) DSD data center channel Trap value in power-on reset : 1 : manufactory test mode 0 : normal operation While only 2 channels output: Microcontroller external interrupt 1 GPIO
224	MC_DATA	INT2#	Inout	Microphone serial input While not support Microphone: Microcontroller external interrupt 2 GPIO
225	SPDIF		Output, 2-16MA, SR : ON/OFF	SPDIF output

■ Video Interface (18)

No.	Name	Alt.	I/O	Function
189	DACVDDC		Power	3.3V power pin for VIDEO DAC circuitry
190	VREF		Analog	Bandgap reference voltage
191	FS		Analog	Full scale adjustment
192	YUV0	CIN	Output 4mA, SR	Video data output bit 0 Compensation capacitor
193	DACVSSC		Ground	Ground pin for VIDEO DAC circuitry
194	YUV1	Y	Output 4mA, SR	Video data output bit 1 Analog Y output
195	DACVDDB		Power	3.3V power pin for VIDEO DAC circuitry
196	YUV2	C	Output 4mA, SR	Video data output bit 2 Analog chroma output
197	DACVSSB		Ground	Ground pin for VIDEO DAC circuitry
198	YUV3	CVBS	Output 4mA, SR	Video data output bit 3 Analog composite output
199	DACVDDA		Power	3.3V power pin for VIDEO DAC circuitry
200	YUV4	Y/G	Output 4mA, SR	Video data output bit 4 Green or Y
201	DACVSSA		Ground	Ground pin for VIDEO DAC circuitry
202	YUV5	B/Cb/Pb	Output 4mA, SR	Video data output bit 5 Blue or CB
203	YUV6	R/Cr/Pr	Output 4mA, SR	Video data output bit 6 Red or CR
205	VSYN	V_ADIN1	Inout 4mA, SR SMT	Vertical sync input/output While no External TV-encoder: Vertical sync for video-input Version AD input port 1 GPIO
206	YUV7	INT3# ASDATA5	Inout 4mA, SR SMT	Video data output bit 7 While no External TV-encoder: Microcontroller external interrupt 3 Audio serial data 5 part II : DSD data sub-woofer channel or Microphone output GPIO
207	HSYN	INT4# V_ADIN2	Inout 4mA, SR SMT	Horizontal sync input/output While no External TV-encoder: Horizontal sync for video-input Microcontroller external interrupt 4 Version AD input port 2 GPIO

■ MISC (8)

No.	Name	Alt.	I/O	Function
43	USB_VSS		USB Ground	USB ground pin
44	USBP		Analog Inout	USB port DPLUS analog pin
45	USBM		Analog Inout	USB port DMINUS analog pin
46	USB_VDD3		USB Power	USB Power pin 3.3V
110	PRST#		Input PU, SMT	Power on reset input, active low
109	ICE		Input PD, SMT	Microcontroller ICE mode enable
228	XTALO		Output	27M crystal out
229	XTALI		Input	27M crystal in

■ DRAM Interface (63)(sorted by position)

No.	Name	Alt.	I/O	Function
188	RD16	LLC_CLK SMPTE_C[0]	Inout Pull-Down	DRAM data 16 While using 16-bits wide DRAM: Line Locked Clock input/output Digital Video output C bit 0 GPIO
187	RD17	YUVIN0 SMPTE_C[1]	Inout Pull-Down	DRAM data 17 While using 16-bits wide DRAM: Video input data 0 Digital Video output C bit 1 GPIO
186	RD18	YUVIN1 SMPTE_C[2]	Inout Pull-Down	DRAM data 18 While using 16-bits wide DRAM: Video input data 1 Digital Video output C bit 2 GPIO
185	RD19	YUVIN2 SMPTE_C[3]	Inout Pull-Down	DRAM data 19 While using 16-bits wide DRAM: Video input data 2 Digital Video output C bit 3 GPIO
184	RD20	YUVIN3 SMPTE_C[4]	Inout Pull-Down	DRAM data 20 While using 16-bits wide DRAM: Video input data 3 Digital Video output C bit 4 GPIO
183	RD21	YUVIN4 SMPTE_C[5]	Inout Pull-Down	DRAM data 21 While using 16-bits wide DRAM: Video input data 4 Digital Video output C bit 5 GPIO
181	RD22	YUVIN5 SMPTE_C[6]	Inout Pull-Down	DRAM data 22 While using 16-bits wide DRAM: Video input data 5 Digital Video output C bit 6 GPIO
180	RD23	YUVIN6 SMPTE_C[7]	Inout Pull-Down	DRAM data 23 While using 16-bits wide DRAM: Video input data 6 Digital Video output C bit 7 GPIO
179	DQM2	YUVIN7	Inout Pull-Up	Data Mask 2 While using 16-bits wide DRAM: Video input data 7 GPIO
178	DQM3	INT6# SMPTE_CLK USB_CLK	Inout Pull-Up	Data Mask 3 While using 16-bits wide DRAM: Microcontroller external interrupt 6 Digital Video output Clock USB port CLK input (48MHz) part II GPIO
177	RD24	SDIN1 MS_BS SMPTE_Y[0]	Inout Non-pull	DRAM data 24 While using 16-bits wide DRAM: Serial interface port 1 data-in MS Card BS pin part II Digital Video output Y bit 0 GPIO
176	RD25	SDO1 MS_SDIO SMPTE_Y[1]	Inout Non-pull	DRAM data 25 While using 16-bits wide DRAM: Serial interface port 1 data-out MS Card SDIO pin part II Digital Video output Y bit 1 GPIO

No.	Name	Alt.	I/O	Function
174	RD26	SDCS1 MSCLK SMPTE_Y[2]	Inout Non-pull	DRAM data 26 While using 16-bits wide DRAM: Serial interface port 1 chip select Memory Stick Clock part II Digital Video output Y bit 2 GPIO
172	RD27	SCLK2 SDCLK SMPTE_Y[3]	Inout Non-pull	DRAM data 27 While using 16-bits wide DRAM: Serial interface port 2 clock pin Security Disk Clock part II Digital Video output Y bit 3 GPIO
171	RD28	SDIN2 SD_CMD SMPTE_Y[4]	Inout Non-pull	DRAM data 28 While using 16-bits wide DRAM: Serial interface port 2 data-in SD Card CMD pin part II Digital Video output Y bit 4 GPIO
170	RD29	SDO2 SD_DAT SMPTE_Y[5]	Inout Non-pull	DRAM data 29 While using 16-bits wide DRAM: Serial interface port 2 data-out SD Card Data pin part II Digital Video output Y bit 5 GPIO
169	RD30	SDCS2 SMPTE_Y[6]	Inout Pull-Up	DRAM data 30 While using 16-bits wide DRAM: Serial interface port 2 chip select Digital Video output Y bit 6 GPIO
168	RD31	INT5# ASDATA5 SMPTE_Y[7]	Inout Pull-Up	DRAM data 31 While using 16-bits wide DRAM: Microcontroller external interrupt 5 Audio serial data 5 part III : DSD data sub-woofer channel or Microphone output Digital Video output Y bit 7 GPIO
166	RA4		Inout	DRAM address 4
165	RA5		Inout	DRAM address 5
164	RA6		Inout	DRAM address 6
162	RA7		Inout	DRAM address 7
160	RA8		Inout	DRAM address 8
159	RA9		Inout	DRAM address 9
158	RA11	GPIO	Inout Pull-Down	DRAM address bit 11 While using DRAM size <=4MB: GPIO
157	CKE		output	DRAM clock enable
156	RCLK		Inout	DRAM clock
154	RCLKB	USB_CLK	Inout	DRAM clock invert While not using DDR: I) USB port CLK input (48MHz) part I
153	RVREF	V_ADIN3	Analog Inout	Reference voltage for DDR DRAM While not using DDR : Version AD input port 3
151	RA3		Inout	DRAM address 3
150	RA2		Inout	DRAM address 2
149	RA1		Inout	DRAM address 1
147	RA0		Inout	DRAM address 0
146	RA10		Inout	DRAM address 10
145	BA1		Inout	DRAM bank address 1
143	BA0		Inout	DRAM bank address 0

No.	Name	Alt.	I/O	Function
142	RCS#		output	DRAM chip select, active low
140	RAS#		output	DRAM row address strobe, active low
139	CAS#		output	DRAM column address strobe, active low
138	RWE#		output	DRAM Write enable, active low
137	DQM1		Inout	Data mask 1
136	DQS1	INT7# MS_BS	Inout	Data strobe 1 for DDR DRAM While not using DDR: Microcontroller external interrupt 7 MS Card BS pin part I GPIO
135	RD8		Inout	DRAM data 8
133	RD9		Inout	DRAM data 9
132	RD10		Inout	DRAM data 10
131	RD11		Inout	DRAM data 11
130	RD12		Inout	DRAM data 12
129	RD13		Inout	DRAM data 13
128	RD14		Inout	DRAM data 14
126	RD15		Inout	DRAM data 15
125	RD0		Inout	DRAM data 0
124	RD1		Inout	DRAM data 1
123	RD2		Inout	DRAM data 2
121	RD3		Inout	DRAM data 3
120	RD4		Inout	DRAM data 4
118	RD5		Inout	DRAM data 5
117	RD6		Inout	DRAM data 6
115	RD7		Inout	DRAM data 7
114	DQS0	SCLK1 MS_SDIO	Inout	Data strobe 0 for DDR DRAM While not using DDR: Serial interface port 1 clock pin MS Card SDIO pin part I GPIO
113	DQM0		Inout	Data mask 0

■ JTAG Interface (4)

No.	Name	Alt.	I/O	Function
48	TDI	SDO3 V_ADIN4 SD_DAT	Inout	JTAG data in While not using Boundary Scan: Serial interface port 3 data-out Version AD input port 4 SD Card Data pin part I GPIO
49	TMS	SDIN3 V_ADIN5 SD_CMD	Inout	While not using Boundary Scan: Serial interface port 3 data-in Version AD input port 5 SD Card CMD pin part I GPIO
50	TCK	SCLK3 V_ADIN6 SDCLK	Inout	JTAG clock While not using Boundary Scan: Serial interface port 3 clock pin Version AD input port 6 Security Disk Clock part I GPIO
51	TDO	SDCS3 V_ADIN7 MSCLK	Inout	JTAG data out While not using Boundary Scan: Serial interface port 3 chip-select Version AD input port 7 Memory Stick Clock part I GPIO