

Ultra EFIS

Product model number: UX0EFS3xAM / UX0EFS5xAM

Software: version 5.23.0R or more recent

Firmware: version 3.15 or more recent



User and Installation Manual

IMPORTANT: Before using this manual check if your Ultra product model number corresponds to the above model number.

1. Overview	4
2. Installation	5
2.1 Location	5
2.2 Mechanical installation	5
2.3 Connections & wiring	8
3. System Calibration	10
3.1 Horizon alignment calibration (AHRS)	10
3.2 Compass calibration (magnetometer)	11
3.3 Altimeter calibration	13
3.3.1 Field calibration	14
3.3.2 Factory calibration	14
4. System Operation	14
4.1 How to operate the unit	14
4.2 PFD mode	15
4.3 NAV mode	18
4.4 SETUP mode	20
4.5 NMEA-OUT	22
5. Software update	23
6. Alarms and Trouble shooting	24
7. Technical Specifications	25
8. Product conformity information	26
8.1 FCC compliance	26
8.2 EU Declaration of conformity	26
Appendix A - NMEA messages	27

DISCLAIMER & WARNINGS

The information displayed by the Ultra is not certified for use for VFR or IFR flights.
The Ultra is meant as an aid to VFR navigation and is not a substitute for certified EFIS.

All critical flight information is presented for reference only and must be verified by the use.
The Ultra is not a substitute for on-board instruments.

The pilot in command assumes total responsibility and risk associated with the use of this device and remains solely responsible for flying in safe conditions.

AvMap disclaims any liability deriving from an improper use of the device, in a way that may violate the flight and navigation rules, regulations and safety.

1. Overview

Ultra is a complete instrumentation system for primary flight display (PFD) and horizontal situation indicator (HSI) functions. It is a rugged and reliable system designed for fixed panel installation.

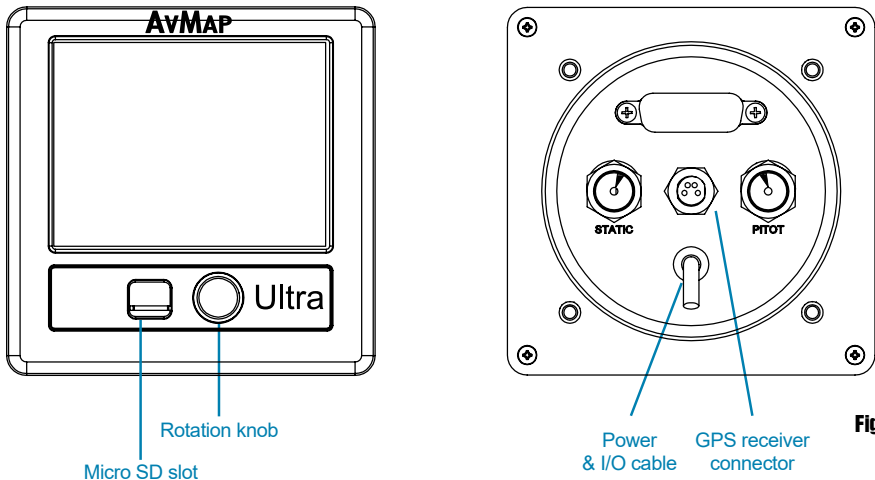

Figure 1

Note: For connection specifications see Chapter 2.

ADAHRS

The core of the Ultra is the ADAHRS module. The ADAHRS module contains solid-state gyros, accelerometers, magnetic field sensors and air data sensors, providing attitude, heading, altitude and airspeed data to the system. In order to take full advantage of its functionality, the Pitot and Static ports should be connected to the aircraft Pitot-static system.

GPS receiver

Connecting the external GPS receiver to the Ultra, the system provides the pilot with navigation information on the HSI page, providing its position, direction and radials relative to reference navigation points.

Preloaded navigation POI's

Ultra is preloaded with Jeppesen navigation POI's: Airports, NDB's and VOR's. Coverage available: Europe-Africa, North America, South America, Asia-Australia. The coverage preloaded on the Ultra is shown on the "INFO" page of the ULTRA POI DATABASE menu. For updates contact orders@avmap.it.

Micro SD card

A microSD card is included in the Ultra box. The microSD card is a blank card without data preloaded. The microSD card should be used for updating the software and navigation POI's.

Note: For more details see Chapter 4.

Rotation knob

The rotor plus centre click allow to switch from one mode to the other and to select different menu option.

Note: For more details see Chapter 4 and 5.

2. Installation

The installation procedure is divided in the following steps:

- Location
- Mechanical installation
- Connections & wiring

2.1 Location

The Ultra is designed to be installed on the aircrafts instrument panel.

It is assumed that the instrument panel is completely perpendicular to the level and straight flight attitude.

In case the instrument panel is rotated the simple horizon alignment calibration procedure is required.

Note: For calibration see Chapter 3.

IMPORTANT: The Ultra contains a magnetometer and other precision electrical sensors. The location selected for installation should be clear of strong magnetic or electromagnetic disturbances as much as possible. Avoid installing the Ultra near electronic equipment (other digital EFIS, radios, transponders, etc), AC or variable DC cables, alternators, electrical motors, ferrous materials, etc. In such cases the proper behaviour of the compass is not guaranteed (i.e. the compass may be crossed as “out of order” or may give erroneous indications).

Hint: use a hand-held compass to verify the magnetic disturbance in the area selected for installation. If the needle shows relevant changes or unstable indication, the location is not suitable for installation. Make sure to perform this test with all on-board electronic devices switched ON.

2.2 Mechanical installation

Make sure you have enough space on the front and behind the cockpit panel to install the Ultra. Check the Ultra measurements on Figure 2.

Ultra is designed to be installed in a standard 3 1/8" (79,5 mm) diameter hole.

The instrument has to be installed from the front of the panel and screwed from behind the panel according to Figure 3.

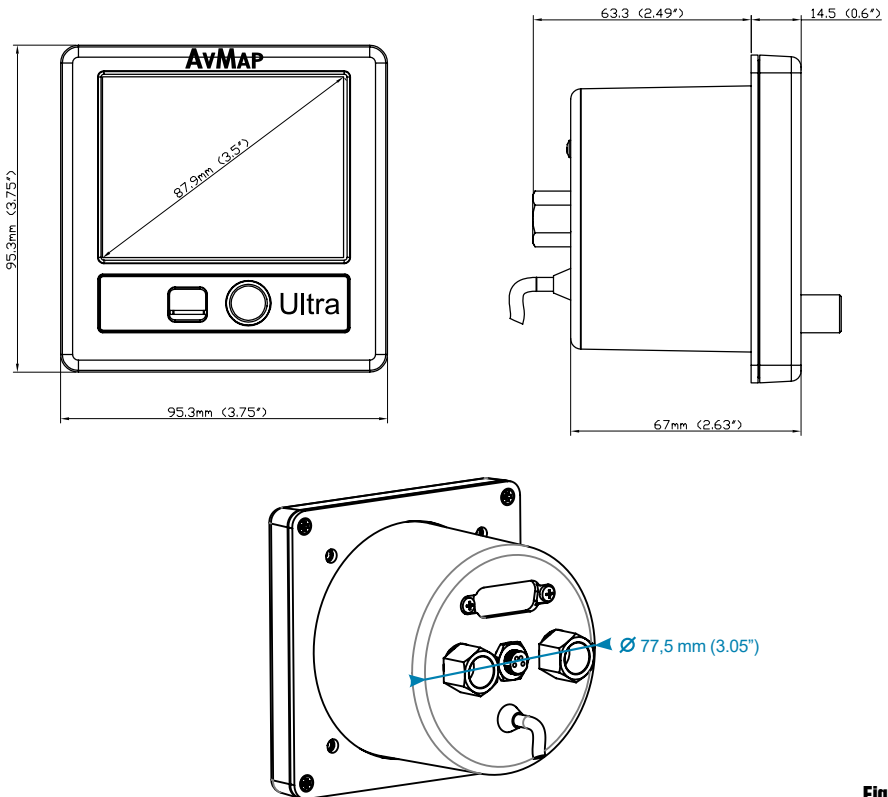

Figure 2

The screw length that need to be used for panel installation depend on the panel thickness and is based on the following formula:

$$5\text{mm} \leq l - t \leq 8\text{mm}$$

l = length of the screw

t = thickness of the panel

Use the screws and metal washer included in the box for standard panel thickness of up to 3mm. For thicker instrument panels, use longer screws and use the formula to choose the right screw length.

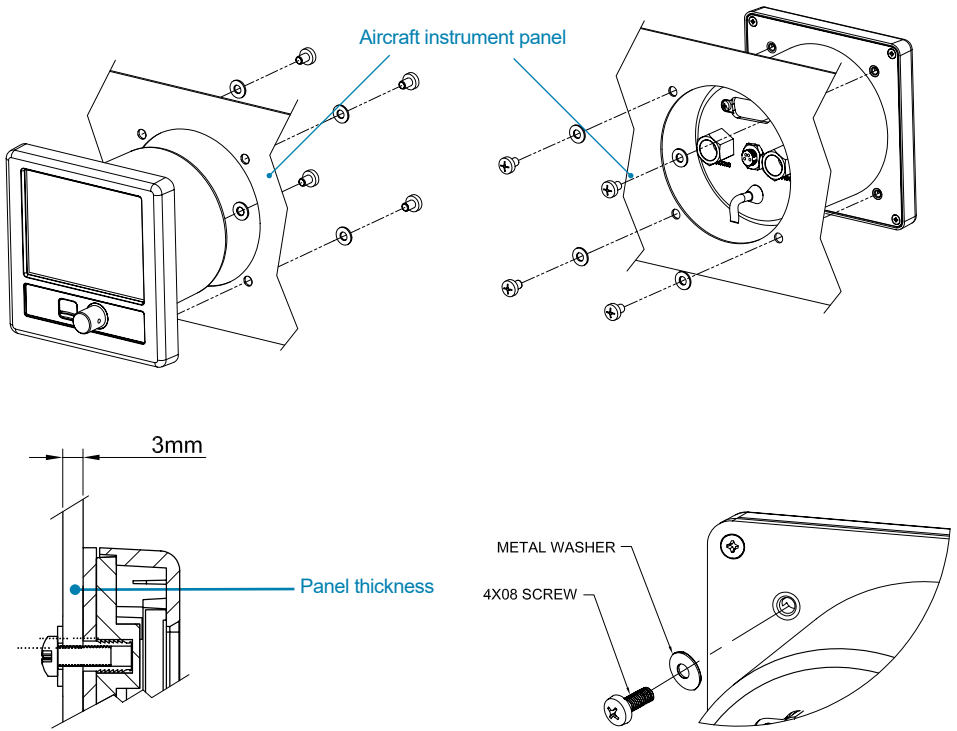

Figure 3

IMPORTANT: Make sure you respect the screw length formula to avoid damaging the plastic of the Ultra. Use light thread locker to prevent screw loosening with vibration. Use the Cutting template, included in the box, to cut out the panel. (see Figure 4)

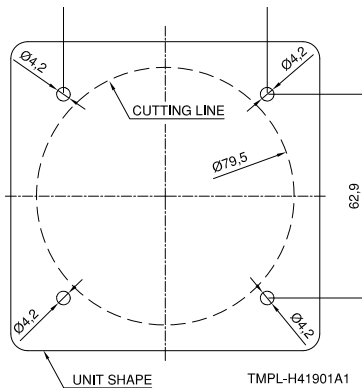

Figure 4

2.3 Connections & wiring

On the back of the unit there are 4 connectors: the Pitot port, the static port, the power supply & serial connector, and the GPS receiver connector (see Figure 5).

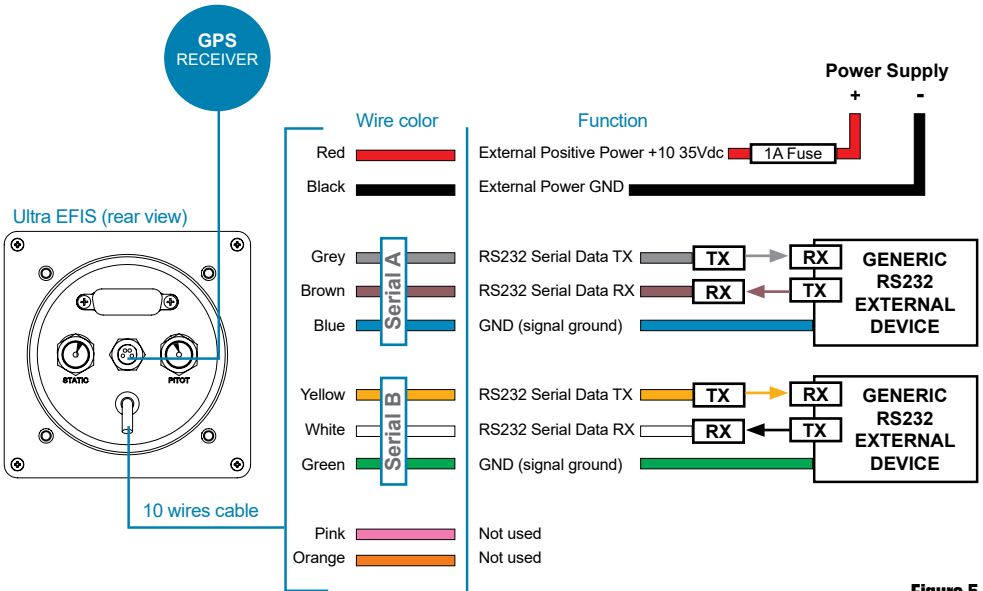

Figure 5

Connection to the Pitot-static system

In order to display accurate speed and altitude data the Ultra needs to be connected to the aircraft Pitot-static system. The Pitot and static ports on the back of the Ultra are equipped with 1/8" NPT female fittings. To connect the aircraft Pitot and static lines to the Ultra, you must use standard 1/8" NPT male fittings at the end of each of the lines. Installation along with other mechanical or digital altimeters and airspeed indicators is supported by mean of a T coupler (not included in the Ultra box).

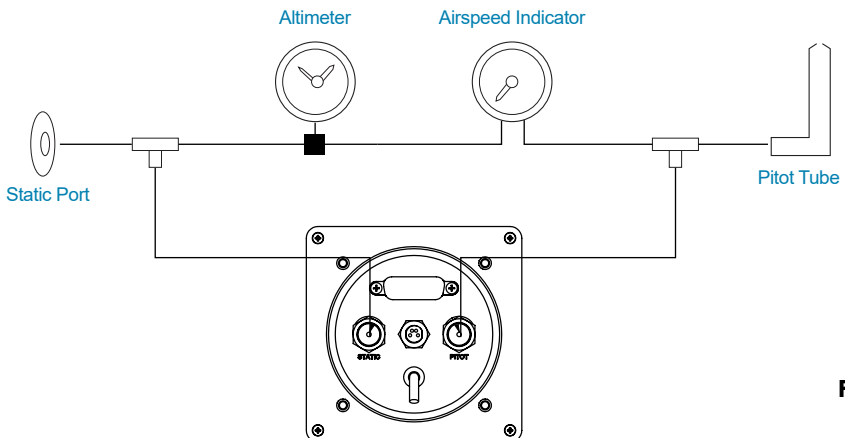

Figure 6

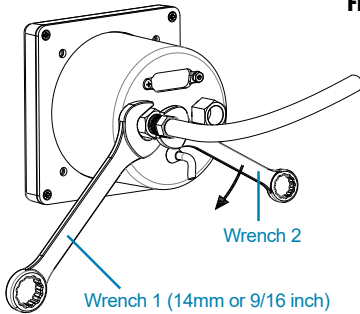

Figure 7

Connect the Pitot line to the port labeled PITOT and the static line to the port labeled STATIC.

IMPORTANT: Use 2 wrenches to screw the NPT male fitting into the NPT female fitting. Use the first wrench (14mm or 9/16 inch) to hold the female fitting on its place, and the second key to screw the male fitting into the female one. Screw carefully until the fittings get tight but avoid overtightening (see Figure 7).

IMPORTANT: Use flexible plastic tubes and make sure the tubes fit tight on the NPT Pitot and static ports and can not get loose due to vibration.

IMPORTANT: We recommend to test the Pitot-static system for leakage after any alteration.

External GPS receiver connection

Connect the external GPS receiver, included in the box, on the back side of the Ultra to the GPS port as shown on Figure 5.

The GPS receiver comes with a 1,5 meter cable and is designed for use inside the aircraft.

Note: an additional gps extension cable of 2 meter is available at the AvMap dealer and AvMap webshop.

The GPS receiver can be mounted to any convenient surface that has a clear view of the sky. It can be mounted on the aircraft's dashboard using the included Velcro strip. The GPS receiver must have a clear view of the sky in order to receive satellite signals. GPS uses "line of sight" signals to locate and track satellites.

If the signals are obstructed by dense objects such as aluminum, steel or even heavy ice, the Ultra will not operate properly. Signals may also be blocked by heated wind screens (fibreglass, plexiglass and other plastics are normally transparent to GPS signals). If you find that the Ultra does not locate GPS FIX quickly or consistently, moving the location of the GPS receiver a few inches often provides a better view of the sky.

Power supply

IMPORTANT: Power the Ultra from an 10 to 35 Vdc supply. Mount on the power wire (RED) the 1A fuse holder, provided in the box, to protect against short circuits.

Serial Connection

Ultra EFIS comes with two RS232 serial connections, both can be enabled for sending out NMEA messages to external devices (see Figure 5):

Connect the Ultra serial TX wire to serial RX wire of the external device.

Connect the Ultra ground (GND) wire to the ground (GND) wire of the external device.

Note: The Ultra is not enabled to receive data through serial, therefore the Ultra serial RX

wire remains out of function and is necessary to be connected to the external device.

Note: See paragraph 4.5 for NMEA-OUT settings.

3. System Calibration

There are three types of calibration procedures;

1. Horizon alignment calibration
2. Compass calibration
3. Altimeter calibration

3.1 Horizon alignment calibration (AHRS)

Scenario A – Horizon alignment calibration NOT required

It is assumed that the Ultra is installed in an instrument panel that is completely perpendicular compared to the level & straight flight attitude and aligned with the lateral axis of the airplane.

In this case no horizon alignment calibration is needed.

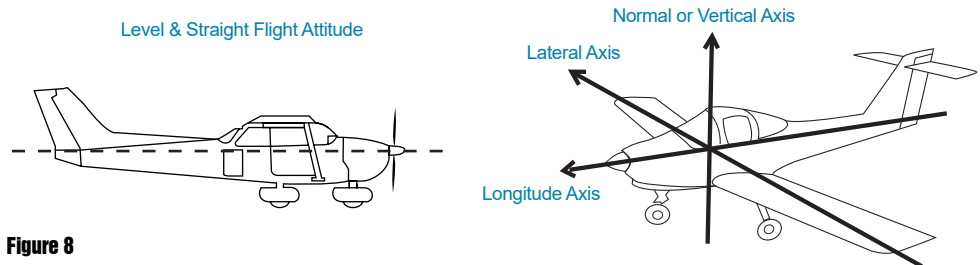

Figure 8

Scenario B - horizon alignment calibration required

In case the Ultra is installed in an instrument panel that is aligned with the aircraft lateral axis, but not perpendicular to the straight & level flight attitude, the simple horizon alignment calibration procedure must be executed.

Note: The horizon calibration corrects also a roll offset, if it is not perfectly aligned with the aircraft lateral axis.

Horizon alignment calibration procedure

Execute this calibration procedure to align the horizon line of the Ultra with the aircraft's straight & level flight attitude.

The procedure can be performed on the ground or in flight (with 2 people on board). The Ultra must be powered since at least 2 minutes before processing the calibration. When performing the calibration on the ground, set the aircraft in level and straight flight attitude by using jacks or blocks (or by asking a friend to push or lift the tail and hold). If it is known that the aircraft flies in "x" degrees 'nose high' straight and level flight, a digital level can be used to orient the aircraft to normal flight attitude prior to the calibration. It is possible to perform

the calibration in flight, but make sure you know the aircraft straight & level flight attitude. AvMap recommends to perform the calibration on the ground.

Note: For a successful calibration in flight, the process should be performed by a second person (not by the pilot) and flight conditions must be safe and stable without wind influence.

Enter the SETUP mode (see chapter 4 System operation) by keeping pressed the rotation knob for 5 seconds and release it.

Push again the rotor knob, select “CALIBRATE” to enter the calibration menu and select “HORIZON” to enter the horizon menu.

In the horizon menu select “ZERO” to calibrate the horizon. After about 2 minutes the horizon line of the Ultra is aligned with the aircrafts straight & level flight attitude.

IMPORTANT: If after the first attempt the horizon is not aligned with the aircrafts straight & level flight attitude, execute the horizon calibration again but before executing the calibration first restore the horizon to “DEFAULT” in the horizon menu.

IMPORTANT: If you want to restore horizon calibration to the factory default (scenario A), select “DEFAULT” in the horizon menu.

IMPORTANT: After a cold startup of the device it may happen that the horizon shows an offset with respect to proper calibration. Wait 2 minutes to let the electronic sensors stabilize before operating the system.

Note: In PFD mode it is possible to adjust the displayed pitch attitude for a maximum of +5° up and -5° down (see paragraph 4.2).

3.2 Compass calibration (magnetometer)

The purpose of this procedure is to compensate magnetic disturbances the Ultra is subject to, due to aircraft metal structures and electromagnetic components. These disturbances, if not compensated, could alter the heading value provided by the system.

For this reason the magnetometer is disabled before the magnetometer calibration procedure is executed.

The procedure requires to point the aircraft nose in 4 directions (north, east, south and west oriented to magnetic north). The total duration for this procedure is about 20 minutes.

IMPORTANT: When the magnetometer of the Ultra is not enabled the Ultra uses GPS source to show COG (course over ground) on the compass. To enable compass heading it is necessary to calibrate the magnetometer. In case both GPS and magnetometer sources are lost the compass becomes RED and is out of order.

IMPORTANT: Before you proceed with the compass calibration, make sure that the horizon line of the Ultra is aligned with the aircrafts straight & level flight attitude (see paragraph 3.1).

IMPORTANT: The compass calibration procedure must be executed in an open field clean

of magnetic disturbances (we recommend at the compass rose of your airport).

Note: Most airports have a compass rose, which is a series of lines marked out on a ramp or maintenance run up area where there is no magnetic interference. Lines, oriented to magnetic north, are painted every 30° which is used to perform a compass calibration.

Compass calibration procedure:

STEP 1: Prepare aircraft position and system

Taxi the aircraft to the airports compass rose or an open field free from magnetic disturbances. Have the aircraft nose pointed to the magnetic north (0°) radial on the airport compass rose.

Note: use a magnetic compass for your reference if you execute the procedure in an open field free from magnetic disturbances).

Set the aircraft in level and straight flight attitude by using jacks or blocks.

Note: Make sure that the horizon line of the Ultra is aligned with the aircrafts straight & level flight attitude.

IMPORTANT: Perform this test with all on-board electronic devices switched ON.

IMPORTANT: Let the Ultra system warm up and stabilize for about 5 minutes before starting the calibration.

IMPORTANT: Check on the HSI display if the Ultra receives a GPS fix.

Note: in case of no GPS reception the Ultra reports on the PFD and HSI page in RED “NO GPS”.

STEP 2: Calibration calculation for north direction

Enter the SETUP mode by keeping the rotation knob pressed for 5 seconds and release (see chapter 4 for further details). Push again the rotor knob, select “CALIBRATE” to enter the calibration menu, then select “COMPASS” and select “CALIBRATE” (“Mag clear done” message will pop up on the display).

The Ultra display shows: “Point to NORTH. Press NEXT when ready”.

Make sure that the aircraft nose is pointed to the magnetic north (0°) radial on the airport compass rose and make sure that the aircraft is not moving. Then confirm by pressing “NEXT”.

Note: The calibration calculation for north direction will start and a counter will inform of the progress.

STEP 3: Calibration calculation for east direction

The Ultra display shows: “Point to EAST. Press NEXT when ready”.

Have the aircraft nose pointed to the magnetic east (90°) radial on the airport compass rose.

Set the aircraft in level and straight flight attitude by using jacks or blocks.

Let the system stabilize for about 30 seconds and make sure that the aircraft is not moving.

Then confirm by pressing “NEXT”.

Note: The calibration calculation for east direction will start and a counter will inform of the progress.

STEP 4: Calibration calculation for south direction

The Ultra display shows: “Point to SOUTH. Press NEXT when ready”.

Have the aircraft nose pointed to the magnetic south (180°) radial on the airport compass rose.

Set the aircraft in level and straight flight attitude by using jacks or blocks.

Let the system stabilize for about 30 seconds and make sure that the aircraft is not moving.

Then confirm by pressing “NEXT”.

Note: The calibration calculation for south direction will start and a counter will inform of the progress.

STEP 5: Calibration calculation for west direction

The Ultra display shows: “Point to WEST. Press NEXT when ready”.

Have the aircraft nose pointed to the magnetic west (270°) radial on the airport compass rose.

Set the aircraft in level and straight flight attitude by using jacks or blocks.

Let the system stabilize for about 30 seconds and make sure that the aircraft is not moving.

Then confirm by pressing “NEXT”.

Note: The calibration calculation for west direction will start and a counter will inform of the progress.

STEP 6: Check compass calibration

At the end of the calibration process the Ultra will confirm if the magnetometer is calibrated successfully.

The message “Calibration done” will pop up.

Note: In the SETUP page after COM 1 will be written “ENABLED MAG”.

IMPORTANT: Don't power off the system. Let the system stabilize for about 15 minutes before moving the aircraft.

Note: In the “SETUP” menu you can choose to display compass heading in reference to magnetic north or true north (see chapter 4).

Note: If the calibration fails or the compass indicator is not enabled, repeat the calibration procedure. If several calibration attempts fails review the installation location of the Ultra. Magnetic disturbance could be too high in the area selected. In alternative, in some aircrafts is experienced that a more precise calibration can be achieved by performing the compass calibration in flight. In flight the aircraft is in a stable and normal flight condition, which is favourable for calibrating the magnetometer and correct magnetic interference. For performing the compass calibration in flight, follow the same calibration instructions and use another source (GPS or compass) to fly into the requested direction. Calibration in flight should be performed by a second person (not the pilot) in safe and stable flight conditions. AvMap disclaims any liability.

3.3 Altimeter calibration

Ultra EFIS contains a barometric altimeter. The included pressure sensor measures atmospheric pressure in order to determine your altitude above mean sea level. The pressure sensor is calibrated at the factory. Nevertheless, due to fluctuations in pressure

over time, it is important to periodically calibrate the altimeter to maintain accurate readings.

AvMap provides two possibilities to calibrate the Ultra EFIS altimeter:

- Field calibration
- Factory calibration

3.3.1 Field calibration

The altimeter field calibration adjust the accuracy of altitude readings via the measured barometric pressure. A field calibration can be done manually on the Ultra EFIS (without removing the device from the panel) by inserting the current elevation and current barometric pressure (QNH).

Procedure:

Select "CALIBRATE" in the "SETUP" menu and select "ALTIMETER" to enter the altimeter calibration menu. To perform the altimeter calibration select "CALIBRATE". To reset to the original factory calibration select "DEFAULT".

Insert the local barometric pressure (QNH) in inHG or hPa, the local elevation in feet or meters and confirm to start the calibration. The device will communicate if the calibration was done successfully or not.

Note: during the calibration process a GPS-fix is required, the device must be powered since at least 5 min and the aircraft must not be in movement.

IMPORTANT: Check periodically the altimeter accuracy and recalibrate when you notice an offset. By any doubt or continuous altimeter offset readings, AvMap recommends to proceed with the altimeter factory calibration.

3.3.2 Factory calibration

The factory calibration is the calibration activity performed in AvMap Laboratory. AvMap recommends to send the Ultra EFIS in factory every 2 years for complete device checkup, including altimeter calibration. Contact avionics@avmap.it to receive information about the complete checkup service costs.

4. System Operation

4.1 How to operate the unit

The Ultra contains three display modes:

1. PFD mode
2. NAV mode
3. SETUP mode

The rotor plus centre click allow to switch from one mode to the other and to select different menu option.

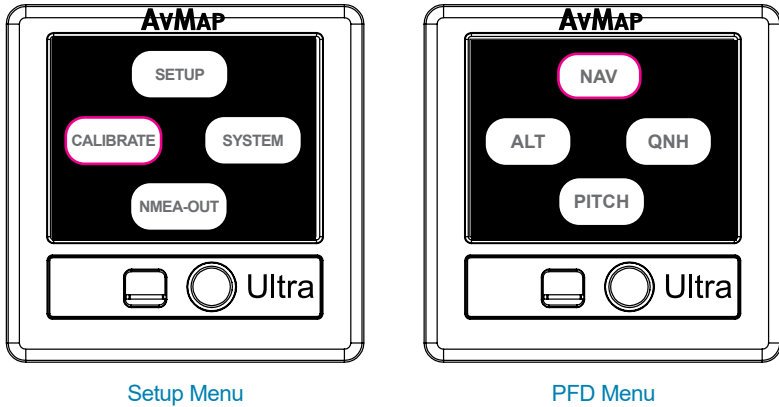

Figure 9

At start up the disclaimer page is shown. In the disclaimer page rotate the knob (or push once the rotation knob) to read the disclaimer and confirm by pushing once the rotation knob to enter the PFD mode.

While in PFD mode, pushing once the rotation knob an option menu window appears on the display. Rotate the knob to select a menu and confirm by pushing the rotation knob. The option menu window disappears if the rotation knob has not been operative for more than 5 seconds.

While in PFD mode, you can enter the NAV mode by pushing the rotation knob, select NAV rotating the knob and confirm by pushing again the rotation knob. To go back to the PFD display mode push the rotation knob, select PFD and confirm by pushing again the rotation knob.

To enter the SETUP mode from either the PFD or NAV mode keep the rotation knob pressed for 5 seconds.

4.2 PFD mode

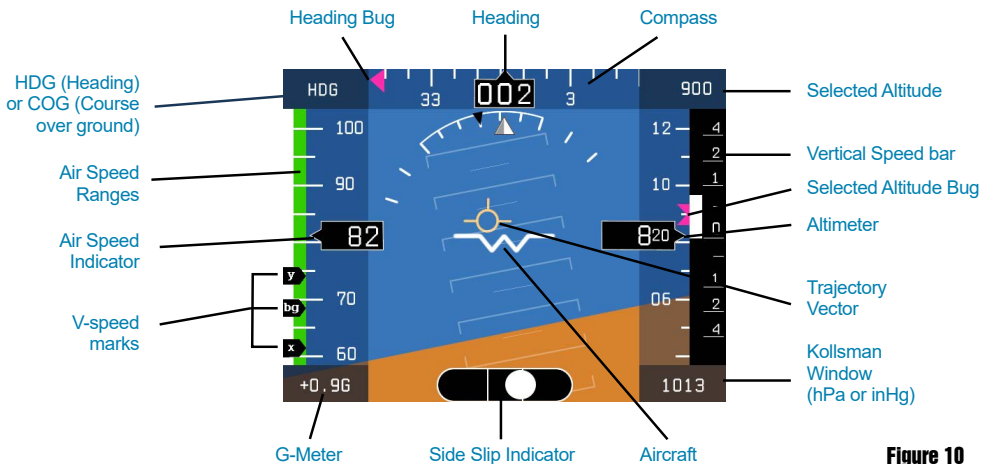

Figure 10

The PFD page shows critical flight information like attitude, airspeed, altitude, as well as other less critical flight variables like turn coordination, heading, load factor (G-Meter). A detailed explanation of each instrument is given in Figure 10.

Attitude is displayed with a standard coloured artificial horizon. A white aircraft symbol is used to indicate the aircraft's nose orientation.

A **trajectory vector** (also called "Flight Path Vector") is displayed with a yellow circle and three lines; the trajectory vector indicates the aircraft's real path with respect to the horizon and the aircraft's nose.

Note: it is possible to enable/disable the trajectory vector symbol in the "PREFERENCE" menu.

Pitch indicator is displayed by markers that are horizontal with the horizon and are equally divided with 5 degrees pitch of separation between the lines.

Pitch adjustment

When the Ultra is in PFD mode the pilot can adjust the displayed pitch attitude by pressing the knob and select "PITCH". In the lower right corner on the display the pitch adjustment is shown, rotate the knob to adjust the pitch attitude. The pitch adjustment function allows the aircraft symbol on the attitude indicator to be adjusted up or down like the aircraft on a mechanical attitude indicator. The pitch can be adjusted for a maximum of 5° up and -5° down.

IMPORTANT: This feature should not be used to compensate or correct a non-conforming installation that does not meet the requirements of the horizon alignment calibration.

Note: Pitch adjustment setting is stored in the internal memory and remembered every time the Ultra is powered OFF/ON. Only after the horizon alignment rest or calibration (see paragraph 3.1) the pitch adjustment setting is reset to 0° as default.

Roll indicator is displayed by markers of 10, 20, 30, 45 and 60 degrees of roll.

Indicated Air Speed (IAS) is shown in number representation as well as on a vertical tape with 5 kts, m/s, kph or mph scale. The tape displays four coloured lines for operating arcs; white from the stall speed in dirty configuration (Vs0) to the maximum flap extension speed (Vfe), green from the stall speed in clean configuration (Vs1) to the maximum cruise speed (Vno), yellow from the maximum cruise speed (Vno) to the never to exceed speed (Vne), and red from the never to exceed speed (Vne) and higher. The tape also displays marks that indicate the speed for best angle of climb (Vx), speed for best rate of climb (Vy) and best glide speed (Vbg).

Note: Aircraft specific V-Speed reference values can be entered in the "SETUP" menu (see paragraph 4.4).

Note: In the "SETUP" menu select your preference unit for speeds: knots, kph, mph, m/s.

Altitude is shown in number representation as well as on a vertical tape with 100 feet or meter scale. Underneath the tape there is a Kollsman window where the user can adjust the QNH setting.

Note: In the “SETUP” menu select your preference unit for altitude: feet (ft), meter (m).

Note: Due to fluctuations in pressure over time, it is important to periodically calibrate the altimeter to maintain accurate readings (see paragraph 3.3).

Side Slip Indicator is shown with a standard ball indicator. The ball centered on the inner markers corresponds to the aircraft not side slipping.

Heading is shown in degrees with respect to magnetic north or true north. The Ultra contains an internal world magnetic model that allows it to calculate the local magnetic deviation and dip. A vertical card compass is also displayed for fast heading reference.

Note: in the “SETUP” menu you can choose reference with respect to magnetic north or true north.

Course over Ground (COG) is shown on the compass instead of heading in case the magnetometer is not calibrated or when the magnetometer has an failure. The COG data is based on GPS source.

Note: If the compass source is GPS, the device shows “COG” aside the compass. If the compass source is the magnetometer, the device shows “HDG” aside the compass. Both can be shown in reference to magnetic north or true north.

Vertical Speed Indicator (VSI) is shown on the black graduated vertical tape with 1000 ft/min scale and thick marks starting from 500 ft/min and a white rate of climb/descent indicator. The unit measurement set for altitude is automatically used on the vertical speed indicator. When altitude is set to feet the VSI is shown in ft/min, when altitude is set to meters the VSI is shown in m/s.

VSI vertical tape in ft/min x 1000:

- 4
- 2
- 1
- 0,5 (tick mark)
- 0

VSI vertical tape in m/s:

- 20
- 10
- 5
- 2,5 (tick mark)
- 0

QNH setting

When the Ultra is in PFD mode the pressure reference for the altimeter can be selected by:

1. Entering the QNH menu:

In PFD mode push the rotation knob. Select “QNH” to enter the QNH menu. Select “BARO” to set the standard atmosphere (QNH value is equal to 1013,25 hPa or 29.92 inch of mercury). Select “MAN” to set manually local air pressure at mean sea level (QNH value). Press the rotation knob to confirm and exit the QNH mode.

2. Using the QNH quick mode:

In the PFD mode, when rotating “fast” the rotation knob you enter directly in the QNH manual mode to set manually local air pressure at mean sea level (QNH value). Press the rotation knob to confirm and exit the QNH mode.

Note: The QNH window mode remains active until the user confirms the selected value by pressing the rotation knob.

Altitude Selector

The “Selected Altitude” is displayed in the upper right corner of the PFD page with a numeric number and indicated on the altimeter bar by a selection bug symbol in magenta colour (Selected Altitude Bug). An arrow (up/down) is shown in case the altitude bug exceeds values of the displayed altimeter bar.

Note: there is no alert feature indicating if you exceed the selected altitude. The selected altitude function is meant as a reminder and to help the pilot to maintain a desired altitude.

Altitude Selector setting

1. Entering the Altitude Selector:

On the PFD menu, press the rotation knob to display the Menu. Select “ALT” followed by “SET” and use the rotation knob to set the desired altitude. Press the knob to confirm.

Note: The Altitude Selector Window mode remains active until the user confirms the selected altitude by pressing the rotation knob.

Note: To disable the Altitude selector press OFF in the ALT menu. Now “ALT OFF” is written in the upper right corner of the PFD page.

2. Using the Quick mode to set the desired altitude

In the PFD mode, when rotating “fast” the rotation knob you enter directly in the Altitude Selector Window to set the Altitude Selector. Press the rotation knob to confirm. After confirming the Altitude Selector you enter directly in the QNH manual mode to set manually the QNH value. Press the rotation knob to confirm and exit the QNH mode. Altitude Selector and QNH values are now both applied.

Note: If the Altitude Selector is enabled the “quick mode feature” is applied on both the ALT and QNH feature. If the ALT bug is set to OFF, the “quick turn feature” will work only for the QNH.

4.3 NAV mode

The NAV page shows navigation data: GPS fix, distance, directions, and radials relative to reference navigation points. Figure 11 shows the data layout on the screen:

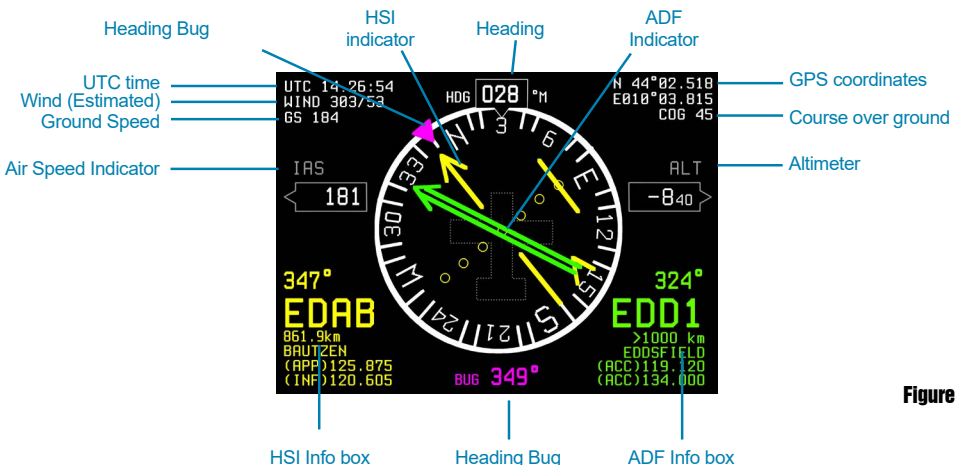

Figure 11

Heading is shown in degrees with respect to magnetic north or true north. The Ultra contains an internal world magnetic model that allows it to calculate the local magnetic deviation and dip. A vertical card compass is also displayed for fast heading reference. **Note:** in the “SETUP” menu you can choose reference with respect to magnetic north or true north.

Course over Ground (COG) is shown on the compass instead of heading in case the magnetometer is not calibrated or when the magnetometer has an failure. The COG value is always shown in a numeric value on the right side of the NAV page. The COG data is based on GPS source. In absence of GPS fix COG value is not available and red dashes are shown.

Note: If the compass source is GPS, the device shows “COG” above the compass. If the compass source is the magnetometer, the device shows “HDG” above the compass. Both can be shown in reference to magnetic north or true north (setup in “UNITS” menu).

GPS fix is confirmed on the right upper corner of the NAV page when GPS coordinates are written in white colour. By absence of a GPS fix “NO GPS” is written in red colour.

Wind data is approximated and displayed by the system when suitable GPS, compass and IAS data are available. Wind direction is referred to the direction where the wind is coming from.

Note: The speed units selected in the “SETUP” menu are also applied to wind speed.

Note: Without compass calibration (see chapter 3) wind data are not available.

Ground Speed (GS) data is based on GPS source and is shown on the left side of the NAV page. In absence of GPS fix ground speed data is not available and red dashes are shown.

Note: In the “SETUP” menu select your preference unit for speeds: knots, kph, mph or m/s.

UTC-time is shown on the upper right corner of the NAV page. GPS fix is required to display UTC-time.

Automatic Direction Finder (ADF) is shown with a standard double line needle in green color. The ADF info box of the navigation POI (Airport, VOR or NDB), used to calculate distance and direction is shown in the bottom right corner. The ADF info box includes the ADF bearing, POI ID, distance (in nm, km or miles), POI name, and two frequencies. The ADF continuously displays the relative bearing from the aircraft to the selected ADF point.

Note: The ADF function on the Ultra is a digital version of the traditional ADF instrument. The Ultra calculates the ADF bearing from its GPS position and coordinates of the selected ADF destination point (from the preloaded POI database).

HSI (horizontal situation indicator) is shown with a standard single line needle in yellow colour. The HSI indicator is complete, with course deviation indicator (CDI) and to/from flag. The HSI info box of the navigation POI (Airport, VOR or NDB), used to

calculate distance and direction is shown in the bottom left corner. The HSI info box displayed includes the radial, POI ID, distance (in nm, km or miles), POI name, and two frequencies.

Note: The HSI function on the Ultra is a digital version of the traditional HSI instrument. The course deviation indicator and TO/FROM flag are based on the selected radial, its GPS position, aircraft heading and the coordinates of the selected HSI destination point (from the preloaded POI database).

HSI navigation settings

When the Ultra is in NAV mode press the rotation knob to enter the NAV menu.

Select "HSI" to enter the HSI menu:

In the "HSI" menu you can select OBS (Omni Bearing Selector), POI, OFF. In the POI menu you can select an Airport (ARPT), VOR and NDB as your navigation point.

Select OBS to set the desired course. Select OFF to disable HSI Navigation and clean the display information.

ADF navigation settings

In the "NAV" menu, select "ADF" to enter the "ADF" menu.

In the "ADF" menu you can select an Airport (ARPT), VOR and NDB as your navigation point. Select OFF to disable ADF navigation and clean the display information.

Note: The destination POI selected in the ADF navigation box is communicated to external devices (like autopilot or any other external device) when NMEA-OUT is enabled. See paragraph 4.5 for more information.

Heading bug

When the Ultra is in NAV mode the heading bug can be selected by:

1. Entering the BUG menu:

In NAV mode push the rotation knob. Select "BUG" to enter the bug window and setup the heading bug on the compass. Use the rotation knob to select the bug direction and confirm by pressing the rotation knob and exit the bug window.

2. Using the BUG quick mode:

In the NAV mode, when rotating "fast" the rotation knob you enter directly in the bug window to setup the heading bug on the compass. Use the rotation knob to select the bug direction and confirm by pressing the rotation knob and exit the bug window.

Note: The bug is shown on the compass in magenta colour, both on the NAV and PFD display.

Note: The bug window mode remains active until the user confirms the selected bug direction by pressing the rotation knob.

4.4 SETUP mode

To enter the SETUP mode from either the PFD or NAV mode keep the rotation knob pressed for 5 seconds.

The SETUP mode provides you information regarding the software version, enabled COM ports, V-speed values and display brightness.

In the SETUP mode push the rotation knob to enter the “SETUP” menu:

In the “SETUP” menu you can enter the following menu’s:

- CALIBRATE: To calibrate the compass, horizon and altimeter .
- NMEA-OUT: To enable or disable Serial A or B ports of the Ultra to send out GPS data (NMEA messages) to external devices.
- SYSTEM: To read the EULA (End-User License Agreement) and enter the Database menu for updating the navigation POI’s, read the actual Ultra POI database coverage and cycle loaded on the system and manage user data points.
- SETUP: To change preference settings like display brightness, configure the aircraft specific V-speed values, change units measurements and reset all settings to factory default.

Note: For compass and horizon calibration see Chapter 3. For NMEA-OUT settings see paragraph 4.5.

Aircraft specific V-speed reference values

Set the aircraft specific V-speed values to get the right information on the air speed ranges bar.

Refer to the aircraft operating manual to find the correct values of your aircraft.

To change V-speed reference values go to the SETUP mode by pressing the rotation knob for 5 seconds.

Select “SETUP” to enter the setup menu and select “SPEEDS” to enter the V-speed reference values shown on the bottom of the SETUP mode.

Rotate the rotation knob to change values and push the rotation knob to confirm.

Note: In the “SETUP” menu select your preference unit for speeds: knots, kph, mph, m/s.

V-speed values	
Vne	Never to exceed speed
Vno	Maximum cruise speed
Vs0	Stall speed with flaps & landing gear deployed
Vfe	Maximum flaps extended speed
Vs1	Stall speed with flaps & landing gear retracted
Vx	Speed for best angle of climb
Vy	Speed for best rate of climb
Vbg	Best glide speed

Navigation POI management

Ultra is preloaded with Jeppesen navigation POI's (Airports, NDB's and VOR's): Ultra POI database.

To read the Ultra POI database coverage and cycle loaded on the system, go to the SETUP mode page, select "SYSTEM", select "DATABASE", select "ULTRA POI", select "INFO". On the "INFO" menu page you can read the database coverage, cycle and validation dates.

The Ultra POI database can be updated through the "IMPORT" menu of the "ULTRA POI" menu by importing an updated database file through the microSD card. An ULTRA POI database file can be ordered directly from AvMap.

To order an Ultra POI database update contact orders@avmap.it and provide the 4 digits EFIS device ID number and coverage. The Ultra EFIS device ID (#xxxx) is shown on the SETUP page of the Ultra).

User Data

In the "DATABASE" menu select "USER DATA" to enter the user database menu.

In the "USER DATA" menu you can enter the following menu's:

- **IMPORT:** Import a database file prepared by AvMap for specific coverages. Check which additional database files are available at the Ultra product page at avionics.avmap.it.
- **EDIT:** Edit existing user points information.
- **NEW:** Create a new user point. Insert ID, Name, LAT/LON, Altitude, and desired information in info-field 1 and info-field 2.
- **DELETE:** Delete existing user points.

Display brightness

Select "BRIGHTNESS" in the "SETUP" menu to adjust the display brightness. Use the rotation knob to change the display brightness and confirm by pushing the rotation knob.

Units measurement settings

To change units measurement select "UNITS" in the "SETUP" menu.

You can change the following units measurements:

- **NORTH:** compass heading can be set in degrees with respect to magnetic north or true north.
- **PRESSURE:** barometric pressure can be set in hPa or inHg.
- **SPEED:** All speed referred information (IAS, wind speed, ground speed, aircraft V-speed range) can be set in knots, kph, mph or m/s.
- **ALTITUDE:** Altitude can be set in feet or meters. The unit measurement set for altitude is used by the altimeter and vertical speed indicator. When altitude is set to feet the vertical speed is shown in ft/min, when altitude is set to meters the VSI is shown in m/s).
- **DISTANCE:** Distance to an VOR or ADF navigation point can be set in nm, miles or km.

4.5 NMEA-OUT

The Ultra EFIS comes with two RS232 serial connections (“Serial A” and “Serial B”), both can be enabled for sending out gps data (NMEA messages) to external devices (autopilot, transponder, navigation or EFIS system). NMEA 0183 protocol is applied for sending out the following NMEA messages: GGA, GSV, GSA, RMC, RMB, APB, APA.

Note: See Appendix A for a description of each NMEA message.

- Select “NMEA-OUT” in the “SETUP” menu and select “Serial A” or “Serial B” in order to setup the desired settings per serial, and confirm by pressing the knob.
- Select ON/OFF in order to enable or disable the NMEA-OUT function, and confirm by pressing the knob.
- Select the required baudrate (4800 / 9600 / 144400 / 19200 / 38400) and confirm by pressing the knob.
- Select ON/OFF for each NMEA message in order to enable or disable the NMEA message to be send out, and confirm by pressing the knob.

IMPORTANT: Check the manual of the connected external device in order to select the required baudrate and NMEA messages for a correct serial interface. It is possible to enable Serial A and Serial B in parallel and select for each serial different NMEA messages and different baudrate. For a successful serial interface the NMEA messages and baudrate settings on the Ultra serial and the connected external device must correspond.

IMPORTANT: NMEA messages that contain destination data (RMC, RMB, APB and APA), often used when connected to an autopilot, navigation or EFIS system, will contain the destination POI selected in the ADF navigation menu. Destination POI's that are selected in the VOR navigation menu are not used by the Ultra when sending out NMEA messages.

IMPORTANT: GPS reception is required in order to send out useful nmea messages data to external devices.

5. Software update

Download the software update file from www.avmap.it/support and copy the software file on the mSD card.

Insert the microSD card into the Ultra while the Ultra is turned OFF.

Turn the Ultra ON providing power supply to the device.

A message will show on the display: “COPY NEW BINARY?”.

Push once the rotation Knob and select “YES” to update the Ultra with the new software, or select “NO” if you don't want to proceed with the update.

After the update process the Ultra starts up as usual. Check the software version in the “SETUP” mode.

6. Alarms and Trouble shooting

Magnetometer not calibrated or not operating correctly

When the magnetometer is either not calibrated or not operating correctly, the compass on the PFD and NAV display becomes RED.

It can occur sporadically during flight and it is not problematic, as the unit continues to estimate heading correctly using gyroscopic and other internal means. Magnetometer failures on start-up or during prolonged periods lead to incorrect heading readings.

What to do?

Perform magnetometer calibration. If the problem persists, and the magnetometer is external, check connection. If problem persists, relocate magnetometer in the aircraft according to installation instructions and recalibrate. If problem still persists, external magnetometer or unit might require service.

GPS failure

During the Ultra start-up and until a GPS fix is acquired, the GPS position field on the NAV display will indicate GPS error in RED. If the GPS fails during operation, the same condition is indicated.

What to do?

Allow for some time (up to 3 minutes) for the GPS to acquire first fix. If failure persists after this point, verify GPS antenna connection.

AHRS failure

When the PFD display mode becomes totally RED there is a AHRS failure. This failure occurs when the unit exceeds any of the following limits: 1600deg/s (all axis) and 8g (all axis).

What to do?

This failure should only occur during high dynamics in flight. The unit will accumulate error in the attitude estimation during these high dynamic conditions, but this error is automatically reduced and eliminated even on dynamic conditions (provided limits are not continuously exceeded). If this failure occurs in non-high dynamic conditions, unit requires service.

Altimeter failure

When the altimeter in the unit is either out of range or not operating correctly the altimeter tape becomes RED.

What to do?

If the altitude is within the limits of the unit (as quoted in the specifications), check for a static port blockage. If the static port is not obstructed, the unit requires service.

Unit failure

When the PFD and NAV display modes show a RED cross the system is not operative. This failure indicates that the sensor system on the unit is no longer speaking to the symbol generator CPU.

What to do?

This problem can occur because the unit is configured wrong, because the software on the device inside it has been erased, or because of an internal failure. The first two causes can be solved by updating the software with the latest available software version. If a software update doesn't resolve the failure the Ultra requires service at AvMap facility.

7. Technical Specifications

Software:

- Airspeed and Altitude from Pitot-static system
- Attitude (roll, pitch and heading) and side slip
- Wind indicator
- HSI with Course Deviation Indicator (CDI)
- Altimeter reference, Heading reference, Aircraft specific V-speed reference values
- Preloaded with Jeppesen navigation POI's (APT, VOR, NDB) for navigation back-up (4 coverages available: North America, South America, Europe-Africa, Asia- Australia)
- Exceptional navigation capability in case of loss of GPS signal
- Load factor (G-meter)
- Vertical speed indicator
- Add user points to the database for navigation
- NMEA 0183 OUT (GGA, GSV, GSA, RMC, RMB, APB, APA)

Hardware:

- Dimensions: 95 x 95 x 78 mm (3.74" x 3.74" x 3.07")
- Diameter: 77,5 mm (3.05"); Installing diameter: 79,5 mm (3 1/8")
- Weight: 230 g (8.1 oz)
- Display: 3.5"; 320 x 240 pixels, brightness 500 cd/m2
- Operational temperature: -20 °C to + 70 °C / -4 °F to +158 °F
- 3-axis gyros, accelerometers and magnetometers
- Acceleration range (3 axis): +/- 8 g
- Rotation range: +/- 1600 deg/s
- Air data sensors: range 10 to 215 kts, -1000 to 40000 ft
- UAV Navigation® Motion processor
- Micro SD slot
- 1.5 m (59") free wires power supply cable (10/35 VDC)
- 2 serial ports RS-232
- Consumption @ 12 V DC: 100 mA nominal

Included accessories:

- GPS receiver U-Blox with 1.5 m (59") cable
- Mounting KIT (cutting template, 4x metal washers and 4x screws)
- 1x 1A fuse holder
- Blank microSD card
- Microfiber cleaner cloth

8. Product conformity information

8.1 FCC compliance

This equipment has been tested and found to comply with the limits for a Class A digital device, pursuant to part 15 of the FCC Rules. These limits are designed to provide reasonable protection against harmful interference when the equipment is operated in a commercial environment. This equipment generates, uses, and can radiate radio frequency energy and, if not installed and used in accordance with the instruction manual, may cause harmful interference to radio communications. Operation of this equipment in a residential area is likely to cause harmful interference in which case the user will be required to correct the interference at his own expense.

Changes or modifications not expressly approved by AvMap Satellite Navigation could void the user's authority to operate the equipment.

Compliance information statement

Identification of the product	Name	P/N
	Ultra EFIS	UX0EFS50AM, UX0EFS51AM, UX0EFS52AM, UX0EFS53AM
Applicable compliance statements	This device complies with part 15 of the FCC Rules. Operation is subject to the following two conditions: (1) This device may not cause harmful interference, and (2) This device must accept any interference received, including interference that may cause undesired operation.	
Responsible party	Name	AvMap Satellite Navigation Inc.
	Address	25 Enterprise Zone Drive, Riverhead, NY 11901 USA
	Phone	+1-800-363-2627
	Website	www.avmap.us

8.2 EU Declaration of conformity

This device complies with Directive 2014/30/EU and Directive 2014/35/EU

The full text of the EU declaration of conformity is available at the following internet address: eudeclaration.avmap.it

Appendix A - NMEA messages

APA Autopilot Sentence “A” contains navigation receiver warning flag status, crosstrackerror, Waypoint arrival status and initial bearing from origin Waypoint to the destination Waypoint for the active navigation leg of the journey.

APB Autopilot message contains all of the above plus: heading to steer toward destination, bearing from the present position to the destination (magnetic or true).

GGA GPS position, time, fix quality, number of satellites used, height of antenna, HDOP (Horizontal Dilution of Precision), differential reference information and age.

GSA GPS receiver operating mode, satellites used in the navigation solution reported by the \$— GGA sentence.

GSV Number of satellites in view, satellite numbers, elevation, azimuth, and SNR value.

RMB Data status, Cross Track Error, direction to steer, origin, destination Waypoint, Waypoint location, bearing to destination and velocity toward the destination.

RMC Time, Latitude, Longitude, Speed Over Ground, Course Over Ground and date.

For information about the NMEA format specifications: www.nmea.org.

Ultra EFIS

AvMap Srl

Viale Zaccagna 6,
54033 Carrara (MS), Italy
www.avmap.it
support@avmap.it

AvMap Satellite Navigation Inc.

25 Enterprise Zone Drive,
Riverhead, NY 11901, USA
www.avmap.us

AvMap do Brasil Ltda

Rua Barao de Santo Angelo, 368 Sala C
95052-610 Jardelino Ramos, Caxias do Sul – RS, Brazil
www.avmap.com.br

